

MA30EUM  
 MA50EUM  
 MA35EUM  
 MA150EUM  
 MA225EUM  
 MA600EUM  
 MA900EUM

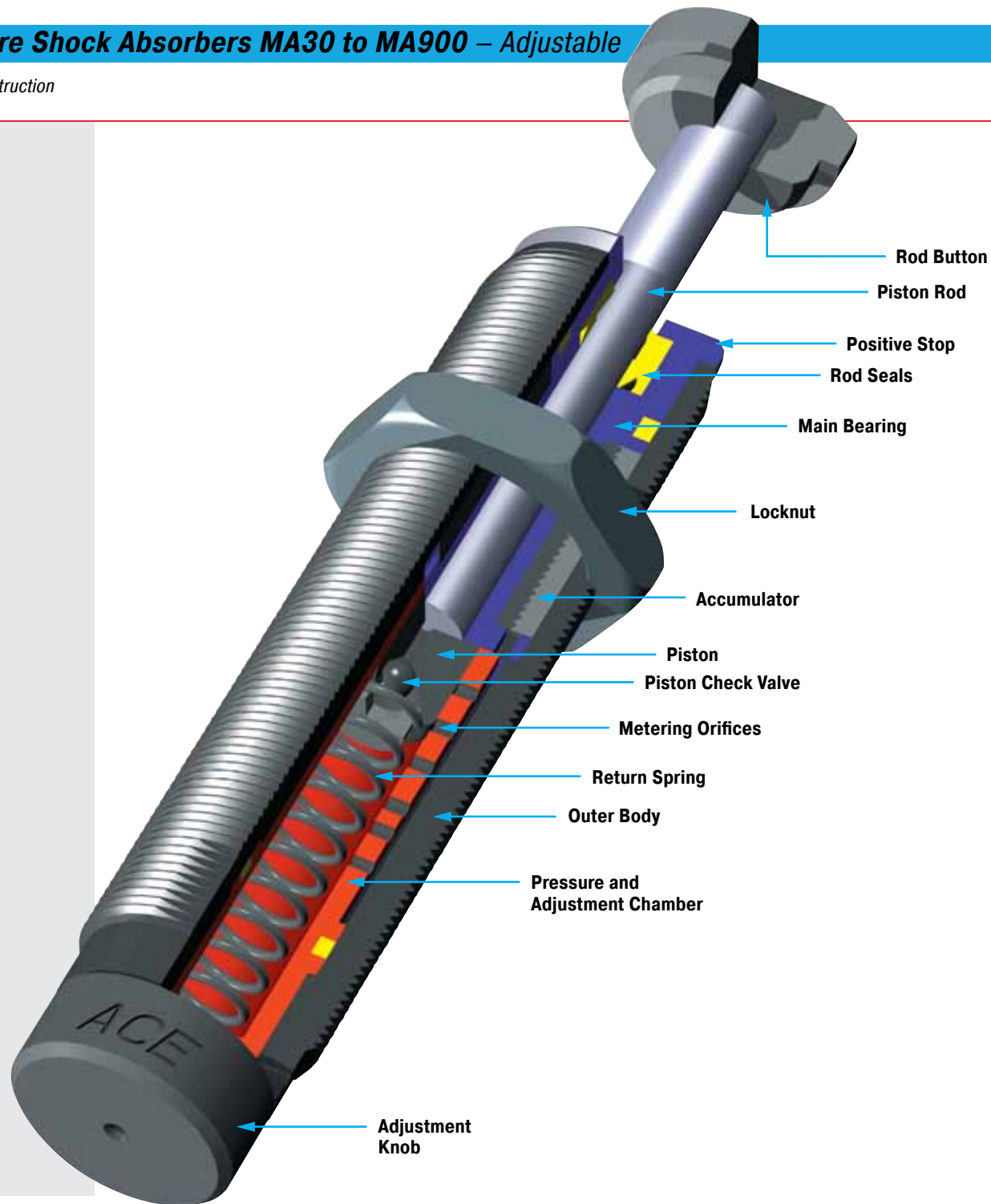

Content	Page
General information .....	2
Safety information .....	2
Purpose .....	2
Description and function .....	2
Calculation and dimensioning .....	2
Delivery and storage .....	2
Maintenance and care .....	2
Dismantling and disposal .....	2
Mounting Instructions .....	3 – 9
Warranty .....	10
Technical Data .....	10
Mounting Instructions for accessories .....	A – C

### General information

This operating manual serves the purpose of fault-free use of the miniature shock absorber types listed on page 1, compliance is a prerequisite for fulfilment of any warranty claims.

Please read the operating manual before use.

Always comply with the limit values provided in the performance table (technical data).

Please consider the prevailing environmental conditions and stipulations.

Please pay attention to the regulations from the trade association, technical inspection association or the corresponding national, international and European regulations.

Only install and commission in accordance with the assembly instructions.

tent deceleration is the correct calculation of the industrial shock absorber and the optimum setting of the damping according to the respective application after mounting.

### General Function

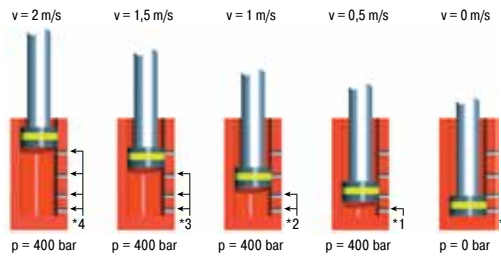
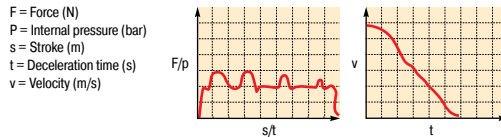

\* The load velocity reduces continuously as you travel through the stroke due to the reduction in the number of metering orifices (\*) in action. The internal pressure remains essentially constant and thus the Force vs. stroke curve remains linear.

### Calculation and dimensioning

In order to guarantee the long life time of the shock absorber it must be correctly calculated and dimensioned. To do this the following parameters must be considered:

- > moving mass [kg]
- > impact velocity of moving mass onto the shock absorber [m/s]
- > additional acting propelling force, motor power or propelling torque [N, kW, Nm]
- > number of parallel acting shock absorbers [n]
- > number of strokes or cycles per hour [1/h]

The correct dimensioning of shock absorbers can be made with the ACE online calculation program at [www.ace-ace.com](http://www.ace-ace.com). Alternatively the filled out online form may be sent to us via E-Mail. Or call our free of charge calculation service: +49-(0)2173-9226-20.

### Safety information

#### WARNING

- ⚠ Additional security elements must be used if ACE miniature shock absorbers are to be used where failure of the product could lead to personal damage and/or damage to property.
- ⚠ Free moving masses can lead to injuries due to crushing when installing the shock absorber. Protect moving masses against unintentional start-up with suitable safety precautions before installing the shock absorbers.

### Purpose

ACE miniature shock absorbers are used anywhere where moving masses have to be stopped at a defined end position. The industrial shock absorbers are designed to take the force in an axial direction. Within the authorised load limits, the industrial shock absorbers also works as a mechanical stop.

### Description and function

The ACE miniature shock absorbers MA30 to MA900 are maintenance-free, ready-to-install, hydraulic elements with a number of throttle openings.

In the braking process, the moving mass drives the piston rod with kinetic energy, and possibly with additional drive energy, in an axial direction with the defined impact speed against the impact head on the shock absorber. As an alternative, several shock absorbers can be used in parallel. In the braking process, the piston rod is pushed into the shock absorber. The hydraulic oil in front of the piston is forced through all the orifices in the inner tube. The number of open orifices then reduces in proportion to the driven stroke. The impact speed reduces.

**Note:** Types MA30 to MA150 work with just one throttle bore.

The dynamic pressure in front of the piston corresponds with the counterforce applied by the shock absorber and remains almost constant throughout the whole stroke. A prerequisite for consis-

#### WARNING

- ⚠ The shock absorbers have to be dimensioned in such a way that the calculated values do not exceed the maximum values of the individual capacity chart (technical data):  
 $W_3$  [Nm/stroke]  
 $W_4$  [Nm/h]  
 effective weight me  
 max. side load angle [°]
- ⚠ To correctly calculate the shock absorber it must be the only active brake system in place. Additional deceleration systems, such as pneumatic cushioning, must be rendered ineffective and not allowed to interfere with the shock absorber deceleration.

### Delivery and storage

- > Please check the shock absorber for any damage upon delivery.
- > The shock absorbers can suffer damage if allowed to fall. Please remove the shock absorbers carefully from the packaging.
- > Shock absorbers can generally be stored in any position.
- > Storage in the original packaging is recommended.
- > Always store shock absorbers in a dry place to avoid oxidation.
- > The maximum recommended storage time is three years.

### Maintenance and care

Check the shock absorbers regularly for oil loss, piston rod return and external damages.

Shock absorbers are machine elements that are subjected to constant wear and tear. The absorbing effect reduces during the service life. When this is no longer sufficient, the shock absorbers must be replaced or exchanged.

### Dismantling and disposal

Ensure that the shock absorbers are dealt with under consideration of environmental protection (problematic substance utilisation). The MA miniature shock absorbers are filled with oil. You can request the corresponding data sheets for the respective type. Defective absorbers can be sent to our services department to establish the cause of failure.

### Mounting instructions

Prior to installation and use, check if the identification number on the shock absorber or on the package corresponds to the number on the delivery sheet. Industrial shock absorbers are maintenance-free and ready-to-fit.

**Operating temperature range:** 0 °C to 66 °C

**Mounting:** In any position, but always so that the complete stroke can be used. The shock absorber is to be mounted so that the forces can be guided centrally via the piston rod.

The maximum permissible side load of 2° should not be exceeded. An existing side load leads generally to a reduced lifetime. When exceeding the maximum permissible side load, a side load adaptor should be used.

### Disposal of packaging

Dispose of packaging in an environmentally safe manner. The recycling of packaging saves raw materials and lowers the amount of waste. The used packaging materials do not contain illegal substances.

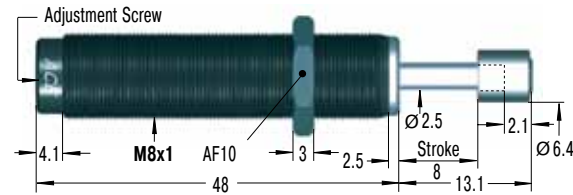

WARNING	
	<b>Thermal effect:</b> The values given in the capacity chart $W_4$ and $m_e$ (see operating and installation instructions or main catalogue) are valid for room temperature. Different values apply for higher temperatures.
	Moving masses can lead to injuries or bodily harm when installing the shock absorber. Secure moving masses against accidental movement.
	The shock absorbers may be unsuitable for the application and show insufficient damping performance. Check for proper suitability of shock absorber.
	When operating outside the allowed temperature range, the shock absorber may lose its functionality. Permissible temperature range must be adhered to. Do not paint the shock absorber due to heat radiation.
	Ambient fluids, gases and dirt particles may affect or damage the sealing system and lead to failure of the shock absorber. Piston rods and sealing systems must be protected against foreign substances.
	Damage to the piston rod surface may destroy the sealing system. Do not grease, oil, etc. the piston rod and protect it from dirt particles.
	The piston rod can be torn out of the shock absorber. Do not put tensile stress on the piston rod.
	The shock absorber can tear off upon impact. The mount must be calculated so that the maximum operating reaction forces can be accepted with sufficient safety. The maximum reaction forces given in the calculation report may deviate from the actual reaction forces since these are based on theoretical values.
	A setting of the dampers to the respective application is mandatory. A wrong setting of the damping could lead to an increased machine load and a premature failure of the shock absorbers.

### Initial Start-Up and Adjustment

After mounting the shock absorber, the equipment must be cycled several times, and the adjuster is turned until the optimum adjustment is reached. A hard impact at the beginning of stroke means: adjustment too hard.

Turn the adjuster clockwise (according to model towards 9, i. e. plus). A hard impact at the end of stroke means: adjustment too soft. Turn the adjuster counterclockwise (towards 0, i. e. minus). The shock absorber is preset to 5 upon delivery.

### Mounting Options

<p><b>Usage of the mounting blocks MBSC2</b></p> <p>Tightening torque: KM8 = 4.0-4.3 Nm</p>	<p><b>Usage of the rectangular flange RF</b></p>
<p><b>Screwing in the shock absorbers into a tapped hole with an additional locknut</b></p> <p>Tightening torque: KM8 = 4.0-4.3 Nm</p> <p>Minimum thread depth: 1.5 x thread diameter</p>	<p><b>Mounting the shock absorbers in the tapped hole with two locknuts</b></p> <p>Tightening torque: KM8 = 4.0-4.3 Nm</p>

### Accessories

When using accessories and mounting elements, please consider the separate mounting instructions for accessories.

### EU Marking

Starting with the production date September 2010 (Code IB or 10244) all shock absorbers are to be marked with an additional EU letter code in the identification number. The EU marking refers to the adherence to the required norms, laws, and guidelines of the EU. Only products marked with EU ensure the worldwide standard and the guarantee of liability.

### Mounting instructions

Prior to installation and use, check if the identification number on the shock absorber or on the package corresponds to the number on the delivery sheet. Industrial shock absorbers are maintenance-free and ready-to-fit.

**Operating temperature range:** 0 °C to 66 °C

**Mounting:** In any position, but always so that the complete stroke can be used. The shock absorber is to be mounted so that the forces can be guided centrally via the piston rod.

The maximum permissible side load of 2° should not be exceeded. An existing side load leads generally to a reduced lifetime. When exceeding the maximum permissible side load, a side load adaptor should be used.

### Disposal of packaging

Dispose of packaging in an environmentally safe manner. The recycling of packaging saves raw materials and lowers the amount of waste. The used packaging materials do not contain illegal substances.

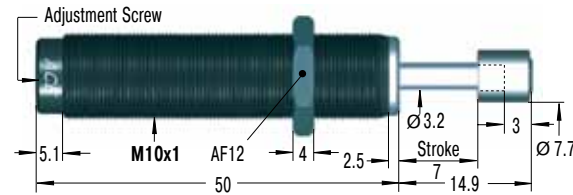

WARNING	
	<b>Thermal effect:</b> The values given in the capacity chart $W_4$ and $m_e$ (see operating and installation instructions or main catalogue) are valid for room temperature. Different values apply for higher temperatures.
	Moving masses can lead to injuries or bodily harm when installing the shock absorber. Secure moving masses against accidental movement.
	The shock absorbers may be unsuitable for the application and show insufficient damping performance. Check for proper suitability of shock absorber.
	When operating outside the allowed temperature range, the shock absorber may lose its functionality. Permissible temperature range must be adhered to. Do not paint the shock absorber due to heat radiation.
	Ambient fluids, gases and dirt particles may affect or damage the sealing system and lead to failure of the shock absorber. Piston rods and sealing systems must be protected against foreign substances.
	Damage to the piston rod surface may destroy the sealing system. Do not grease, oil, etc. the piston rod and protect it from dirt particles.
	The piston rod can be torn out of the shock absorber. Do not put tensile stress on the piston rod.
	The shock absorber can tear off upon impact. The mount must be calculated so that the maximum operating reaction forces can be accepted with sufficient safety. The maximum reaction forces given in the calculation report may deviate from the actual reaction forces since these are based on theoretical values.
	A setting of the dampers to the respective application is mandatory. A wrong setting of the damping could lead to an increased machine load and a premature failure of the shock absorbers.

### Initial Start-Up and Adjustment

After mounting the shock absorber, the equipment must be cycled several times, and the adjuster is turned until the optimum adjustment is reached. A hard impact at the beginning of stroke means: adjustment too hard.

Turn the adjuster clockwise (according to model towards 9, i. e. plus). A hard impact at the end of stroke means: adjustment too soft. Turn the adjuster counterclockwise (towards 0, i. e. minus). The shock absorber is preset to 5 upon delivery.

### Mounting Options

<p><b>Usage of the mounting blocks MBSC2</b></p> <p>Tightening torque: KM10 = 4.0-4.3 Nm</p>	<p><b>Usage of the rectangular flange RF</b></p>
<p><b>Screwing in the shock absorbers into a tapped hole with an additional locknut</b></p> <p>Tightening torque: KM10 = 4.0-4.3 Nm</p> <p>Minimum thread depth: 1.5 x thread diameter</p>	<p><b>Mounting the shock absorbers in the tapped hole with two locknuts</b></p> <p>Tightening torque: KM10 = 4.0-4.3 Nm</p>

### Accessories

When using accessories and mounting elements, please consider the separate mounting instructions for accessories.

### EU Marking

Starting with the production date September 2010 (Code IB or 10244) all shock absorbers are to be marked with an additional EU letter code in the identification number. The EU marking refers to the adherence to the required norms, laws, and guidelines of the EU. Only products marked with EU ensure the worldwide standard and the guarantee of liability.

### Mounting instructions

Prior to installation and use, check if the identification number on the shock absorber or on the package corresponds to the number on the delivery sheet. Industrial shock absorbers are maintenance-free and ready-to-fit.

**Operating temperature range:** 0 °C to 66 °C

**Mounting:** In any position, but always so that the complete stroke can be used. The shock absorber is to be mounted so that the forces can be guided centrally via the piston rod.

The maximum permissible side load of 2° should not be exceeded. An existing side load leads generally to a reduced lifetime. When exceeding the maximum permissible side load, a side load adaptor should be used.

### Disposal of packaging

Dispose of packaging in an environmentally safe manner. The recycling of packaging saves raw materials and lowers the amount of waste. The used packaging materials do not contain illegal substances.

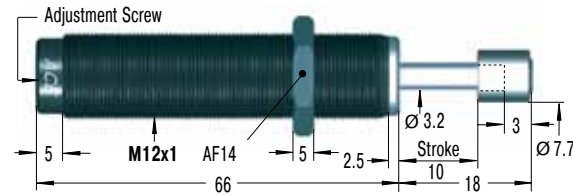

### WARNING

- Thermal effect:** The values given in the capacity chart  $W_4$  and  $m_e$  (see operating and installation instructions or main catalogue) are valid for room temperature. Different values apply for higher temperatures.
- Moving masses** can lead to injuries or bodily harm when installing the shock absorber. Secure moving masses against accidental movement.
- The shock absorbers may be unsuitable for the application and show insufficient damping performance. Check for proper suitability of shock absorber.
- When operating outside the allowed temperature range, the shock absorber may lose its functionality. Permissible temperature range must be adhered to. Do not paint the shock absorber due to heat radiation.
- Ambient fluids, gases and dirt particles may affect or damage the sealing system and lead to failure of the shock absorber. Piston rods and sealing systems must be protected against foreign substances.
- Damage to the piston rod surface may destroy the sealing system. Do not grease, oil, etc. the piston rod and protect it from dirt particles.
- The piston rod can be torn out of the shock absorber. Do not put tensile stress on the piston rod.
- The shock absorber can tear off upon impact. The mount must be calculated so that the maximum operating reaction forces can be accepted with sufficient safety. The maximum reaction forces given in the calculation report may deviate from the actual reaction forces since these are based on theoretical values.
- A setting of the dampers to the respective application is mandatory. A wrong setting of the damping could lead to an increased machine load and a premature failure of the shock absorbers.

### Initial Start-Up and Adjustment

After mounting the shock absorber, the equipment must be cycled several times, and the adjuster is turned until the optimum adjustment is reached. A hard impact at the beginning of stroke means: adjustment too hard.

Turn the adjuster clockwise (according to model towards 9, i. e. plus). A hard impact at the end of stroke means: adjustment too soft. Turn the adjuster counterclockwise (towards 0, i. e. minus). The shock absorber is preset to 5 upon delivery.

### Mounting Options

#### Usage of the clamp mount MB

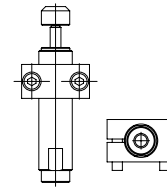

#### Usage of the rectangular flange RF

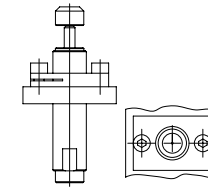

#### Screwing in the shock absorbers into a tapped hole with an additional locknut

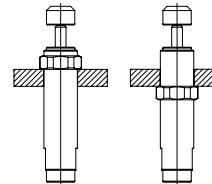

Tightening torque:  
KM12 = 5.0-5.4 Nm

Minimum thread depth:  
1.5 x thread diameter

#### Mounting the shock absorbers in the tapped hole with two locknuts

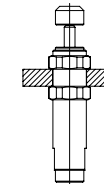

Tightening torque:  
KM12 = 5.0-5.4 Nm

### Accessories

When using accessories and mounting elements, please consider the separate mounting instructions for accessories.

### EU Marking

Starting with the production date September 2010 (Code IB or 10244) all shock absorbers are to be marked with an additional EU letter code in the identification number. The EU marking refers to the adherence to the required norms, laws, and guidelines of the EU. Only products marked with EU ensure the worldwide standard and the guarantee of liability.

### Mounting instructions

Prior to installation and use, check if the identification number on the shock absorber or on the package corresponds to the number on the delivery sheet. Industrial shock absorbers are maintenance-free and ready-to-fit.

**Operating temperature range:** 0 °C to 66 °C

**Mounting:** In any position, but always so that the complete stroke can be used. The shock absorber is to be mounted so that the forces can be guided centrally via the piston rod.

The maximum permissible side load of 2° should not be exceeded. An existing side load leads generally to a reduced lifetime. When exceeding the maximum permissible side load, a side load adaptor should be used.

### Disposal of packaging

Dispose of packaging in an environmentally safe manner. The recycling of packaging saves raw materials and lowers the amount of waste. The used packaging materials do not contain illegal substances.

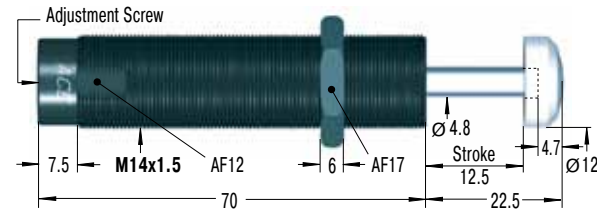

WARNING	
	<b>Thermal effect:</b> The values given in the capacity chart $W_4$ and $m_e$ (see operating and installation instructions or main catalogue) are valid for room temperature. Different values apply for higher temperatures.
	Moving masses can lead to injuries or bodily harm when installing the shock absorber. Secure moving masses against accidental movement.
	The shock absorbers may be unsuitable for the application and show insufficient damping performance. Check for proper suitability of shock absorber.
	When operating outside the allowed temperature range, the shock absorber may lose its functionality. Permissible temperature range must be adhered to. Do not paint the shock absorber due to heat radiation.
	Ambient fluids, gases and dirt particles may affect or damage the sealing system and lead to failure of the shock absorber. Piston rods and sealing systems must be protected against foreign substances.
	Damage to the piston rod surface may destroy the sealing system. Do not grease, oil, etc. the piston rod and protect it from dirt particles.
	The piston rod can be torn out of the shock absorber. Do not put tensile stress on the piston rod.
	The shock absorber can tear off upon impact. The mount must be calculated so that the maximum operating reaction forces can be accepted with sufficient safety. The maximum reaction forces given in the calculation report may deviate from the actual reaction forces since these are based on theoretical values.
	A setting of the dampers to the respective application is mandatory. A wrong setting of the damping could lead to an increased machine load and a premature failure of the shock absorbers.

### Initial Start-Up and Adjustment

After mounting the shock absorber, the equipment must be cycled several times, and the adjuster is turned until the optimum adjustment is reached. A hard impact at the beginning of stroke means: adjustment too hard.

Turn the adjuster clockwise (according to model towards 9, i. e. plus). A hard impact at the end of stroke means: adjustment too soft. Turn the adjuster counterclockwise (towards 0, i. e. minus). The shock absorber is preset to 5 upon delivery.

### Mounting Options

<p><b>Usage of the clamp mount MB</b></p>	<p><b>Usage of the rectangular flange RF</b></p>
<p><b>Screwing in the shock absorbers into a tapped hole with an additional locknut</b></p> <p>Tightening torque: KM14 = 13-14 Nm Minimum thread depth: 1.5 x thread diameter</p>	<p><b>Mounting the shock absorbers in the tapped hole with two locknuts</b></p> <p>Tightening torque: KM14 = 13-14 Nm</p>

### Accessories

When using accessories and mounting elements, please consider the separate mounting instructions for accessories.

### EU Marking

Starting with the production date September 2010 (Code IB or 10244) all shock absorbers are to be marked with an additional EU letter code in the identification number. The EU marking refers to the adherence to the required norms, laws, and guidelines of the EU. Only products marked with EU ensure the worldwide standard and the guarantee of liability.

### Mounting instructions

Prior to installation and use, check if the identification number on the shock absorber or on the package corresponds to the number on the delivery sheet. Industrial shock absorbers are maintenance-free and ready-to-fit.

**Operating temperature range:** 0 °C to 66 °C

**Mounting:** In any position, but always so that the complete stroke can be used. The shock absorber is to be mounted so that the forces can be guided centrally via the piston rod.

The maximum permissible side load of 2° should not be exceeded. An existing side load leads generally to a reduced lifetime. When exceeding the maximum permissible side load, a side load adaptor should be used.

the shock absorber's adjustment and locked again afterwards. A corresponding hexagon wrench is included. The shock absorber is preset to 5 upon delivery.

### Disposal of packaging

Dispose of packaging in an environmentally safe manner. The recycling of packaging saves raw materials and lowers the amount of waste. The used packaging materials do not contain illegal substances.

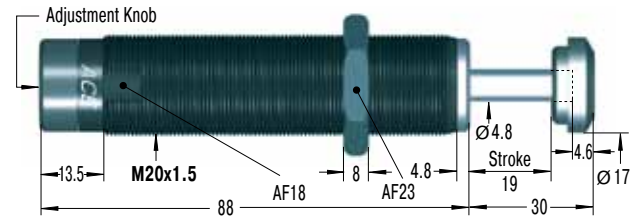

WARNING	
	<b>Thermal effect:</b> The values given in the capacity chart $W_d$ and $m_e$ (see operating and installation instructions or main catalogue) are valid for room temperature. Different values apply for higher temperatures.
	<b>Moving masses</b> can lead to injuries or bodily harm when installing the shock absorber. Secure moving masses against accidental movement.
	The shock absorbers may be unsuitable for the application and show insufficient damping performance. Check for proper suitability of shock absorber.
	When operating outside the allowed temperature range, the shock absorber may lose its functionality. Permissible temperature range must be adhered to. Do not paint the shock absorber due to heat radiation.
	Ambient fluids, gases and dirt particles may affect or damage the sealing system and lead to failure of the shock absorber. Piston rods and sealing systems must be protected against foreign substances.
	Damage to the piston rod surface may destroy the sealing system. Do not grease, oil, etc. the piston rod and protect it from dirt particles.
	The piston rod can be torn out of the shock absorber. Do not put tensile stress on the piston rod.
	The shock absorber can tear off upon impact. The mount must be calculated so that the maximum operating reaction forces can be accepted with sufficient safety. The maximum reaction forces given in the calculation report may deviate from the actual reaction forces since these are based on theoretical values.
	A setting of the dampers to the respective application is mandatory. A wrong setting of the damping could lead to an increased machine load and a premature failure of the shock absorbers.

### Initial Start-Up and Adjustment

After mounting the shock absorber, the equipment must be cycled several times, and the adjuster is turned until the optimum adjustment is reached. A hard impact at the beginning of stroke means: adjustment too hard.

Turn the adjuster clockwise (according to model towards 9, i. e. plus). A hard impact at the end of stroke means: adjustment too soft. Turn the adjuster counter-clockwise (towards 0, i. e. minus).

For models MA225EUM, MA600EUM und MA900EUM, the adjuster is secured with a setscrew. This must be loosened prior to

### Mounting Options

<p><b>Usage of the clamp mount MB</b></p>	<p><b>Usage of the rectangular flange RF</b></p>
<p><b>Screwing in the shock absorbers into a tapped hole with an additional locknut</b></p> <p>Tightening torque: KM20 = 27-30 Nm</p> <p>Minimum thread depth: 1.5 x thread diameter</p>	<p><b>Mounting the shock absorbers in the tapped hole with two locknuts</b></p> <p>Tightening torque: KM20 = 27-30 Nm</p>

### Accessories

When using accessories and mounting elements, please consider the separate mounting instructions for accessories.

### EU Marking

Starting with the production date September 2010 (Code IB or 10244) all shock absorbers are to be marked with an additional EU letter code in the identification number. The EU marking refers to the adherence to the required norms, laws, and guidelines of the EU. Only products marked with EU ensure the worldwide standard and the guarantee of liability.

### Mounting instructions

Prior to installation and use, check if the identification number on the shock absorber or on the package corresponds to the number on the delivery sheet. Industrial shock absorbers are maintenance-free and ready-to-fit.

**Operating temperature range:** 0 °C to 66 °C

**Mounting:** In any position, but always so that the complete stroke can be used. The shock absorber is to be mounted so that the forces can be guided centrally via the piston rod.

The maximum permissible side load of 2° should not be exceeded. An existing side load leads generally to a reduced lifetime. When exceeding the maximum permissible side load, a side load adaptor should be used.

the shock absorber's adjustment and locked again afterwards. A corresponding hexagon wrench is included. The shock absorber is preset to 5 upon delivery.

### Disposal of packaging

Dispose of packaging in an environmentally safe manner. The recycling of packaging saves raw materials and lowers the amount of waste. The used packaging materials do not contain illegal substances.

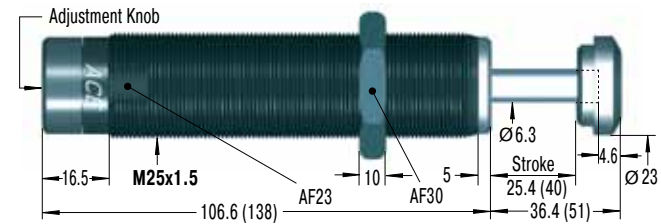

Dimensions in ( ) refer to MA900

### Mounting Options

#### Usage of the clamp mount MB

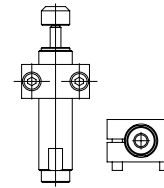

#### Usage of the rectangular flange RF

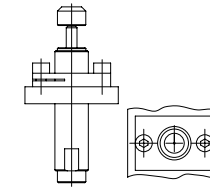

#### Screwing in the shock absorbers into a tapped hole with an additional locknut

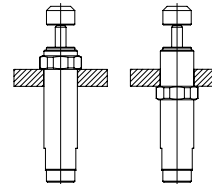

Tightening torque:  
KM25 = 60-66 Nm

Minimum thread depth:  
1.5 x thread diameter

#### Mounting the shock absorbers in the tapped hole with two locknuts

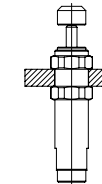

Tightening torque:  
KM25 = 60-66 Nm

### WARNING

- Thermal effect:** The values given in the capacity chart  $W_d$  and  $m_e$  (see operating and installation instructions or main catalogue) are valid for room temperature. Different values apply for higher temperatures.
- Moving masses** can lead to injuries or bodily harm when installing the shock absorber. Secure moving masses against accidental movement.
- The shock absorbers may be unsuitable for the application and show insufficient damping performance. Check for proper suitability of shock absorber.
- When operating outside the allowed temperature range, the shock absorber may lose its functionality. Permissible temperature range must be adhered to. Do not paint the shock absorber due to heat radiation.
- Ambient fluids, gases and dirt particles may affect or damage the sealing system and lead to failure of the shock absorber. Piston rods and sealing systems must be protected against foreign substances.
- Damage to the piston rod surface may destroy the sealing system. Do not grease, oil, etc. the piston rod and protect it from dirt particles.
- The piston rod can be torn out of the shock absorber. Do not put tensile stress on the piston rod.
- The shock absorber can tear off upon impact. The mount must be calculated so that the maximum operating reaction forces can be accepted with sufficient safety. The maximum reaction forces given in the calculation report may deviate from the actual reaction forces since these are based on theoretical values.
- A setting of the dampers to the respective application is mandatory. A wrong setting of the damping could lead to an increased machine load and a premature failure of the shock absorbers.

### Initial Start-Up and Adjustment

After mounting the shock absorber, the equipment must be cycled several times, and the adjuster is turned until the optimum adjustment is reached. A hard impact at the beginning of stroke means: adjustment too hard.

Turn the adjuster clockwise (according to model towards 9, i. e. plus). A hard impact at the end of stroke means: adjustment too soft. Turn the adjuster counter-clockwise (towards 0, i. e. minus).

For models MA225EUM, MA600EUM und MA900EUM, the adjuster is secured with a setscrew. This must be loosened prior to

### Accessories

When using accessories and mounting elements, please consider the separate mounting instructions for accessories.

### EU Marking

Starting with the production date September 2010 (Code IB or 10244) all shock absorbers are to be marked with an additional EU letter code in the identification number. The EU marking refers to the adherence to the required norms, laws, and guidelines of the EU. Only products marked with EU ensure the worldwide standard and the guarantee of liability.

### Mounting instructions

Prior to installation and use, check if the identification number on the shock absorber or on the package corresponds to the number on the delivery sheet. Industrial shock absorbers are maintenance-free and ready-to-fit.

**Operating temperature range:** 0 °C to 66 °C

**Mounting:** In any position, but always so that the complete stroke can be used. The shock absorber is to be mounted so that the forces can be guided centrally via the piston rod.

The maximum permissible side load of 1° should not be exceeded. An existing side load leads generally to a reduced lifetime. When exceeding the maximum permissible side load, a side load adaptor should be used.

the shock absorber's adjustment and locked again afterwards. A corresponding hexagon wrench is included. The shock absorber is preset to 5 upon delivery.

### Disposal of packaging

Dispose of packaging in an environmentally safe manner. The recycling of packaging saves raw materials and lowers the amount of waste. The used packaging materials do not contain illegal substances.

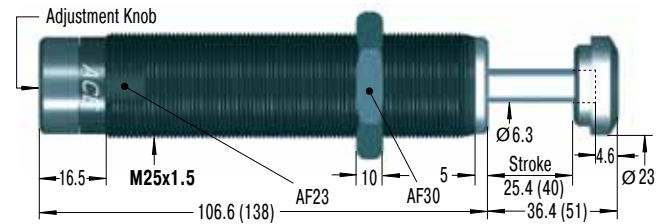

Dimensions in ( ) refer to MA900

### Mounting Options

#### Usage of the clamp mount MB

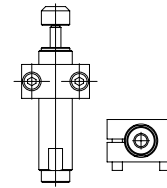

#### Usage of the rectangular flange RF

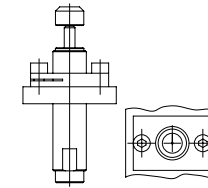

#### Screwing in the shock absorbers into a tapped hole with an additional locknut

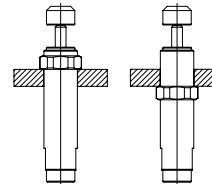

Tightening torque:  
KM25 = 60-66 Nm

Minimum thread depth:  
1.5 x thread diameter

#### Mounting the shock absorbers in the tapped hole with two locknuts

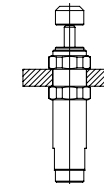

Tightening torque:  
KM25 = 60-66 Nm

### WARNING

- Thermal effect:** The values given in the capacity chart  $W_d$  and  $m_e$  (see operating and installation instructions or main catalogue) are valid for room temperature. Different values apply for higher temperatures.
- Moving masses** can lead to injuries or bodily harm when installing the shock absorber. Secure moving masses against accidental movement.
- The shock absorbers may be unsuitable for the application and show insufficient damping performance. Check for proper suitability of shock absorber.
- When operating outside the allowed temperature range, the shock absorber may lose its functionality. Permissible temperature range must be adhered to. Do not paint the shock absorber due to heat radiation.
- Ambient fluids, gases and dirt particles may affect or damage the sealing system and lead to failure of the shock absorber. Piston rods and sealing systems must be protected against foreign substances.
- Damage to the piston rod surface may destroy the sealing system. Do not grease, oil, etc. the piston rod and protect it from dirt particles.
- The piston rod can be torn out of the shock absorber. Do not put tensile stress on the piston rod.
- The shock absorber can tear off upon impact. The mount must be calculated so that the maximum operating reaction forces can be accepted with sufficient safety. The maximum reaction forces given in the calculation report may deviate from the actual reaction forces since these are based on theoretical values.
- A setting of the dampers to the respective application is mandatory. A wrong setting of the damping could lead to an increased machine load and a premature failure of the shock absorbers.

### Initial Start-Up and Adjustment

After mounting the shock absorber, the equipment must be cycled several times, and the adjuster is turned until the optimum adjustment is reached. A hard impact at the beginning of stroke means: adjustment too hard.

Turn the adjuster clockwise (according to model towards 9, i. e. plus). A hard impact at the end of stroke means: adjustment too soft. Turn the adjuster counter-clockwise (towards 0, i. e. minus).

For models MA225EUM, MA600EUM und MA900EUM, the adjuster is secured with a setscrew. This must be loosened prior to

### Accessories

When using accessories and mounting elements, please consider the separate mounting instructions for accessories.

### EU Marking

Starting with the production date September 2010 (Code IB or 10244) all shock absorbers are to be marked with an additional EU letter code in the identification number. The EU marking refers to the adherence to the required norms, laws, and guidelines of the EU. Only products marked with EU ensure the worldwide standard and the guarantee of liability.

## Warranty

All changes to the product generally lead to exclusion of warranty.

Obvious defects must be immediately notified in writing to the seller upon delivery, within one week at the latest, but always before processing or installation, otherwise enforcement of a warranty claim is excluded. Punctual despatch is sufficient to comply with the deadline.

The seller must be given the opportunity to check on the premises. In the case of an authorised complaint, the seller can choose between an improvement and replacement delivery. If subsequent fulfilment is not successful, the buyer can choose between reducing the payment (reduction) and reversing the contract (withdrawal). The buyer is not entitled to withdraw from the contract in the case of a negligible contract breach; especially negligible defects.

If the buyer chooses to withdraw from the contract due to a legal or material defect after failed subsequent fulfilment, he is not entitled to additional claims to replacement of damages due to a defect.

If the buyer chooses replacement of damages after failed subsequent fulfilment, the goods remain with the buyer where feasible. Replacement of damages is restricted to the difference between the purchase price and the value of the defective item. This does not apply if the seller has caused a fraudulent breach of the contract.

Only the product description from the seller is generally agreed with respect to the properties of the goods. Public statements, promotions or advertising by the manufacturer do not represent contractual properties of the goods. If the buyer receives a faulty set of assembly instructions, the seller is only obliged to supply a correct set of instructions and only if the fault in the assembly instructions oppose correct assembly.

The warranty period is two years and begins upon delivery. The exchange and return of customised production items is generally excluded. The factory conditions in the manufacturing plant, which can be viewed by the ordering party on the seller's premises at any time, apply to parts not produced and processes by the seller. Construction and installation parts are supplied according to the most recent status.

## Life expectancy

Industrial shock absorbers are machine elements that are generally subject to wear and tear. Expendable parts such as seals, pressure parts and pistons are excluded from the general warranty. The wear of the seals essentially depends on the environmental conditions, the respective application and the use parameters.

This type of industrial shock absorber with a lip seal sealing system can generally expect an average service life of three to five million load cycles. Unfavourable environmental and use conditions can considerably reduce the expected service life.

## Capacity Chart

Type	Max. Energy Capacity		Effective Weight me		Min. Return Force N	Max. Return Force N	Rod Reset Time s	'Max. Side Load Angle °	Weight kg
	W <sub>3</sub> Nm/Cycle	W <sub>4</sub> Nm/h	Adjustable						
			me min. kg	me max. kg					
MA30EUM	3.5	5650	0.23	15	1.7	5.3	0.3	2	0.013
MA35EUM	4	6000	6	57	5	11	0.2	2	0.043
MA50EUM	5.5	13550	4.5	20	3	6	0.3	2	0.025
MA150EUM	22	35000	1	109	3	5	0.4	2	0.06
MA225EUM	25	45000	2.3	226	5	10	0.1	2	0.13
MA600EUM	68	68000	9	1360	10	30	0.2	2	0.31
MA900EUM	100	90000	14	2040	10	35	0.4	1	0.4

<sup>1</sup> For applications with higher side load angles please contact ACE.

## Technical Data

Impact velocity range: **0,15 to 4,45 m/s** (Depending on the type, see calculating effective mass)

Rod end button: **Steel hardened**

Piston Rod Seal: **NBR**

Operating fluid: **Special oil** (Data sheets on request)

Piston Rod: **Hardened, stainless steel**

Locknut: **Steel with black oxide finish**

Shock absorber body: **Nitride hardened steel**

Tightening torque Locknut:	MA30: <b>4.3 Nm</b>	MA35: <b>5.4 Nm</b>	MA50: <b>4.3 Nm</b>	MA150: <b>14 Nm</b>
	MA225: <b>30 Nm</b>	MA600: <b>66 Nm</b>	MA900: <b>66 Nm</b>	

Operating temperature range: **0 °C to 66 °C**

## Rectangular Flanges RF6 to RF25

### Mounting instructions

Prior to mounting and application, check if the identification number on the rectangular flange or the packaging corresponds to the ID on the delivery note.

**Mounting position:** In any position, yet always so that the complete stroke can be used. Always mount the rectangular flange in order for the forces to be transferred centrally into the shock absorber or feed control via the piston rod. The maximum permissible side load angle of the individual types (see chart) may not be exceeded. To minimize the unsupported length, it is recommended to mount the rectangular flange in the first third of the outer body.

### Mounting

Assemble the rectangular flange with the provided socket head bolt (DIN 912). The mounting surface must be level. The threads on the connection parts must be able to accept the maximum arising generated forces during continuous operation safely. Refer to technical support of ACE for generated forces. After aligning the rectangular flange and positioning the shock absorber or hydraulic feed control in the required position, tighten the screws with the torque stated in the chart. The shock absorber(s) or hydraulic feed control(s) need not be secured with an additional locknut. The listed product types are secured with the integrated clamp slot while adhering to the recommended tightening torque.

### Disposal of packaging

Dispose packaging in an environmentally safe manner. The recycling of packaging saves raw materials and lowers the amount of waste. The used packaging materials do not contain illegal substances.

### WARNING

- Rectangular flanges RF may only be used with the appropriate ACE shock absorbers or hydraulic feed controls according to chart.
- Rectangular flanges and the corresponding screws are dimensioned so that the maximum arising supporting forces can be accepted safely.
- The correct dimensioning of the shock absorbers or Precision hydraulic feed controls according to ACE catalogue, or mounting/operating manual, is absolutely necessary. Rectangular flanges RF may not be used, when overloading, i.e., a faulty calculation of listed product types has occurred.

## Rectangular Flanges RF6 to RF25

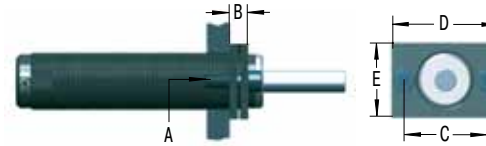

### Rectangular Flange RF

	Type	Max. Side Load Angle °	A	Max. torque Nm	B	C	D	E
RF6	MC9EUM	2	M3x8	3	5	14	20	10
RF8	MA30EUM	2	M4x10	4	6	18	25	14
RF8	MC10EUM	3	M4x10	4	6	18	25	14
RF8	MC30EUM	2	M4x10	4	6	18	25	14
RF10	MA50EUM	2	M4x10	4	6	20	28	14
RF10	MC25EUM	2	M4x10	4	6	20	28	14
RF10	SC25EUM	2	M4x10	4	6	20	28	14
RF12	MA35EUM	2	M5x12	6	6	24	32	20
RF12	MC75EUM	2	M5x12	6	6	24	32	20
RF12	SC75EUM	2	M5x12	6	6	24	32	20
RF14	MA150EUM	2	M5x12	6	6	26	34	20
RF14	MC150EUM	4	M5x12	6	6	26	34	20
RF14	SC190EUM0-4	5	M5x12	6	6	26	34	20
RF14	SC190EUM5-7	2	M5x12	6	6	26	34	20
RF20	MA225EUM	2	M6x14	11	8	36	46	32
RF20	MC225EUM	4	M6x14	11	8	36	46	32
RF20	MVC225EUM	2	M6x14	11	8	36	46	32
RF20	SC300EUM0-4	5	M6x14	11	8	36	46	32
RF20	SC300EUM5-9	5	M6x14	11	8	36	46	32
RF25	MA600EUM	2	M6x14	11	8	42	52	32
RF25	MA900EUM	1	M6x14	11	8	42	52	32
RF25	MC600EUM	2	M6x14	11	8	42	52	32
RF25	MVC600EUM	2	M6x14	11	8	42	52	32
RF25	MVC900EUM	2	M6x14	11	8	42	52	32
RF25	SC650EUM0-4	5	M6x14	11	8	42	52	32
RF25	SC650EUM5-9	5	M6x14	11	8	42	52	32
RF25	SC925EUM	5	M6x14	11	8	42	52	32

## Mounting Block MB5SC2 to MB25SC2

### Mounting instructions

Prior to mounting and application, check if the identification number on the mounting block or the packaging corresponds to the ID on the delivery note.

**Mounting position:** In any position, yet always so that the complete stroke can be used. Always mount the mounting block in order for the forces to be transferred centrally into the shock absorber via the piston rod. The maximum permissible side load angle of the individual shock absorber type (see chart) may not be exceeded. To minimize the unsupported length, it is recommended to mount the mounting block in the first third of the shock absorber body.

### Mounting

Assemble the mounting block with the provided socket head bolt (DIN 912). The mounting surface must be level. The threads on the connection parts or on the connection to the machine must be able to accept the maximum arising generated forces safely. After aligning the mounting block and screwing in the shock absorbers, tighten the screws with the torque stated in the chart. Secure the shock absorber with the locknut against rotation. Refer to chart for required torque.

### Disposal of packaging

Dispose packaging in an environmentally safe manner. The recycling of packaging saves raw materials and lowers the amount of waste. The used packaging materials do not contain illegal substances.

### WARNING



Mounting blocks MBSC2 may only be used with the appropriate ACE shock absorbers according to chart.



The mounting blocks and the corresponding screws are dimensioned so that the maximum arising generated forces can be accepted safely.



The correct dimensioning of the shock absorber according to ACE catalogue, or mounting/operating manual, is absolutely necessary. The mounting blocks MBSC2 may not be used, when overloading, i.e. a faulty calculation of a shock absorber has occurred.

## Mounting Block MB5SC2 to MB25SC2

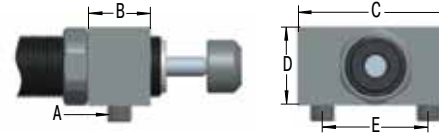

### Mounting Block RF

	Type	Max. Side Load Angle °	A	Max. torque		B	C	D	E
				Screw Nm	Locknut Nm				
MB5SC2	MC5EUM	2	M3x10	3	1.2-1.5	8	20	10	12
MB6SC2	MC9EUM	2	M3x10	3	1.2-1.5	8	20	10	12
MB8SC2	MA30EUM	2	M4x12	5	4	10	25	12	16
MB8SC2	MC10EUM	3	M4x12	5	1.2-1.5	10	25	12	16
MB8SC2	MC30EUM	2	M4x12	5	4-4.3	10	25	12	16
MB10SC2	MA50EUM	2	M4x16	5	4-4.3	10	25	14	16
MB10SC2	MC25EUM	2	M4x16	5	4-4.3	10	25	14	16
MB14SC2	SC190EUM5-7	2	M5x20	9,5	13-14	12	20	32	20
MB20SC2	SC300EUM5-9	5	M6x25	37	27-30	20	28	40	25
MB25SC2	SC650EUM5-9	5	M6x30	37	60-66	25	34	46	32

## Clamp Mount MB12 to MB25

### Mounting instructions

Prior to mounting and application, check if the identification number on the clamp mount or the packaging corresponds to the ID on the delivery note.

**Mounting position:** In any position, yet always so that the complete stroke can be used. Always mount the clamp mount in order for the forces to be transferred centrally into the shock absorber or feed control via the piston rod. The maximum permissible side load angle of the individual shock stroke or feed control absorber type (see chart) may not be exceeded. To minimize the unsupported length, it is recommended to mount the clamp mount in the first third of the outer body.

WARNING	
	Clamp mounts MB may only be used with the appropriate ACE shock absorbers or hydraulic feed controls according to chart.
	The clamp mounts and the corresponding screws are dimensioned so that the maximum arising generated forces can be accepted safely.
	The correct dimensioning of the shock absorbers or Precision hydraulic feed controls according to ACE catalogue, or mounting/operating manual, is absolutely necessary. The clamp mounts MB may not be used, when overloading, i.e., a faulty calculation of listed product types has occurred.

### Mounting

Assemble the clamp mount with the provided socket head bolt (DIN 912). The mounting surface must be level. The threads on the connection parts or on the connection to the machine must be able to accept the maximum arising generated forces safely. After aligning the clamp mount and screwing in the shock absorbers or feed control, tighten the screws with the torque stated in the chart. The shock absorber(s) need not be secured with a locknut. The shock absorber(s) or feed control(s) are secured with the integrated clamp slot while adhering to the recommended tightening torque.

### Disposal of packaging

Dispose packaging in an environmentally safe manner. The recycling of packaging saves raw materials and lowers the amount of waste. The used packaging materials do not contain illegal substances.

## Clamp Mount MB12 to MB25

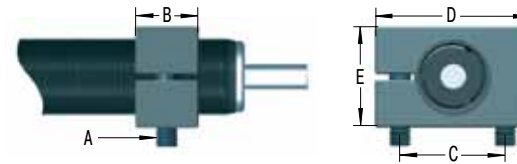

### Clamp Mount MB

	Type	Max. Side Load Angle °	A	Max. torque Nm	B	C	D	E
MB12	MA35EUM	2	M5x16	6	12	20	32	16
MB12	MC75EUM	2	M5x16	6	12	20	32	16
MB14	MA150EUM	2	M5x20	6	12	20	32	20
MB14	MC150EUM	4	M5x20	6	12	20	32	20
MB20	MA225EUM	2	M6x25	11	20	28	40	25
MB20	MC225EUM	4	M6x25	11	20	28	40	25
MB20	MVC225EUM	2	M6x25	11	20	28	40	25
MB25	MA600EUM	2	M6x30	11	25	34	46	32
MB25	MA900EUM	1	M6x30	11	25	34	46	32
MB25	MC600EUM	2	M6x30	11	25	34	46	32
MB25	MVC600EUM	2	M6x30	11	25	34	46	32
MB25	MVC900EUM	2	M6x30	11	25	34	46	32
MB25	SC925EUM	5	M6x30	11	25	34	46	32
MB25	VC2515EUFT	3	M6x30	11	25	34	46	32
MB25	VC2530EUFT	2	M6x30	11	25	34	46	32
MB25	VC2555EUFT	2	M6x30	11	25	34	46	32
MB25	VC2575EUFT	2	M6x30	11	25	34	46	32
MB25	VC25100EUFT	1	M6x30	11	25	34	46	32
MB25	VC25125EUFT	1	M6x30	11	25	34	46	32