

Gas springs are universally accepted, wherever you want to

- push
- pull
- lift
- lower, or
- position

covers, lids or other components by hand without using an external energy source. ACE gas springs are individually filled to a predetermined pressure to suit a customer's requirement (extension Force F_1). The cross-sectional area of the piston rod and filling pressure determines the extension force $F = p \cdot A$. During the compression of the piston rod, nitrogen flows through an orifice in the piston from the full bore side of the piston to the annulus. The nitrogen is compressed by the volume of the piston rod. As the piston rod is compressed the pressure increases, so increasing the reaction force (progression). The force depends on the proportional relationship between the piston rod and the inner tube diameter, which is approximately linear.

Force-Stroke Characteristics of Gas Spring (Push Type)

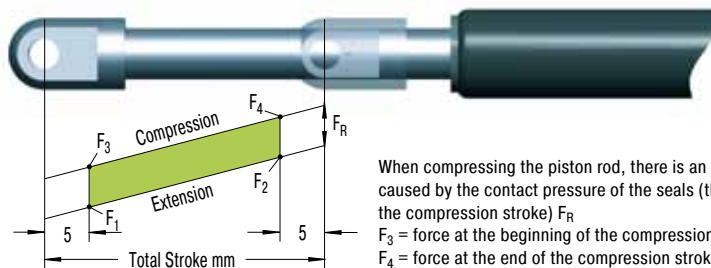

When compressing the piston rod, there is an additional friction force caused by the contact pressure of the seals (this only occurs during the compression stroke) F_R
 F_3 = force at the beginning of the compression stroke
 F_4 = force at the end of the compression stroke

F_1 = nominal force at 20 °C (this is the pressure figure normally used when specifying the gas spring)

F_2 = force in the complete compressed position

Force-Stroke Characteristics of Traction Gas Spring (Pull Type)

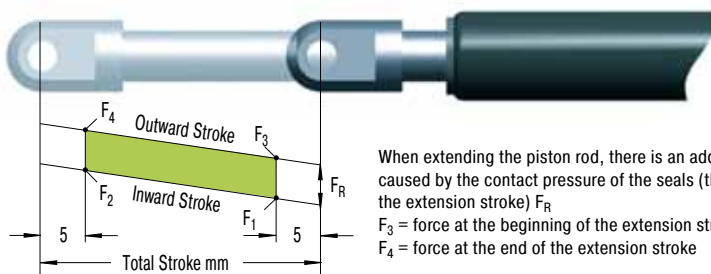

When extending the piston rod, there is an additional friction force caused by the contact pressure of the seals (this only occurs during the extension stroke) F_R
 F_3 = force at the beginning of the extension stroke
 F_4 = force at the end of the extension stroke

F_1 = nominal force at 20 °C (this is the pressure figure normally used when specifying the gas spring)

F_2 = force in the complete extended position

Gas Springs (Push Type)

Type	¹ Progression approx. %	² Friction F_R approx. in N
GS-8	28	10
GS-10	20	10
GS-12	25	20
GS-15	27	20
GS-19	36 - 42 ³	30
GS-22	39 - 50 ³	30
GS-28	60 - 95 ³	40
GS-40	47 - 53 ³	50
GS-70	25	50

Gas Springs (Pull Type)

Type	¹ Progression approx. %	² Friction F_R approx. in N
GZ-15	23	55 - 140
GZ-19	10	20 - 40
GZ-28	20	100 - 200
GZ-40	40	

¹ The progression (the slope of the force line in the diagrams above) is due to the reduction of the internal gas volume as the piston rod moves from its initial position to its fully stroked position. The approx. progression values given above for standard springs can be altered on request.

Effect of temperature: The nominal F_1 figure is given at 20 °C. An increase of 10 °C will increase force by 3.4%.

Filling tolerance on F_1 force: -20 N to +40 N or 5% to 7%

² Depending on the filling force.

³ Depending on the stroke.

Service Life

Filling tolerance: -20 N to +40 N or 5% to 7%

Effect of temperature: An increase in temperature of each 10 °C will increase force by approx. 3.4 %.

Temperature range: -20 °C to +80 °C (special seals from -45 °C to 200 °C)

Mounting: The gas springs should ideally be installed with the **piston rod pointing downwards** to use the end damping during the extension stroke to smoothly decelerate the motion of the gas spring. Some ACE gas springs have a uniquely designed front bearing with an integrated grease chamber allowing the gas spring to be mounted and operated in any position if required.

When fitting the gas springs ensure that the stroke is fully extended (GZ type fully compressed), this makes assembly and disassembly much easier. **Support the moving mass/flap during assembly or disassembly to prevent accidents. To avoid twisting or side loading, it is recommended that ball joints or other pivoted mounting attachments are used.** The mounting attachments must always be securely tightened onto the threaded studs of the gas spring.

ACE gas springs are maintenance-free. DO NOT oil or grease the piston rod!

The piston rod must be protected from any hits, scratches or dirt and especially paint. Damage to the surface finish of the piston rod will destroy the sealing system and cause loss of pressure. The outer body must not be deformed or mechanically damaged.

ACE gas springs can be stored in any position. Experience has shown that long storage periods do not result in loss of pressure. However you may experience some "stiction" requiring a higher effort to move the gas spring for the first time after a long storage period.

Generally, ACE gas springs are tested to 70 000 to 100 000 complete strokes. This is equivalent to the seal lifetime (depending on model size) to a distance travelled of 2 km up to 10 km. During these tests the gas spring must not lose more than 5% of its pressure. Depending upon the application and operating environment, the service life of these gas springs may be much longer. In practise 500 000 strokes or more have been achieved on some applications.

Lifetime for traction gas spring see pages 189 to 197.

Adjustment Instructions Valve



Adjustment Instruction

1. Hold gas spring piston rod down.
2. Remove any fitting attached to the body end of the gas spring (GZ-19 to GZ-40 version the piston rod).
3. Insert adjuster knob on thread end on the cylinder body (on GZ-19 to GZ-40 version thread end on the piston rod). When resistance is felt, proceed slowly and with caution. This opens the valve and you can hear the nitrogen escaping and reducing pressure. Turn back the adjusting knob immediately, to avoid too much nitrogen being discharged.
4. After adjustment, remove the adjuster knob, mount the end fittings and test the gas spring in your application. If necessary repeat the procedure.

If you use 2 gas springs in parallel, both gas springs should have the same force to avoid bending forces or side load on the application. If necessary return to ACE to refill both gas springs to the same (average) force. If too much nitrogen is discharged, the units can be returned to ACE for re-gassing.

Gas Spring Refilling Kit



The **ACE gas spring refilling kit** offers you the opportunity to fill gas springs on location or adapt them individually. The refilling kit is equipped with all the parts you need to fill gas springs. Very precise filling of the gas springs is possible using the digital manometer. The table for determining the filling pressure of the gas springs is included with the case. The only thing missing from the delivery is the nitrogen.

The refilling kit contains all filling bells and adjuster knobs for the current ACE gas spring range.

Ordering name: Complete gas spring refilling kit

"Independence and flexibility!"



The refilling kit suits 200 bar nitrogen bottles with a thread of W24,32x1/14" (German standard). Other connections are available upon request.

Gas springs filled with the refilling kit must be measured on a calibrated measurement system by ACE for repeat production.

Calculation

To obtain the ideal selection to give the optimum operation for a gas spring it is important to identify the following points:

- gas spring size
- required gas spring stroke
- mounting points on flap and frame
- extended length of the gas spring
- required extension force
- hand forces throughout the complete movement on the flap

With our **free calculation service** you can eliminate the time-consuming calculation and send us your details by fax or e-mail. Just complete the information shown on the calculation formulae page number 165. Please attach a sketch of your application (a simple hand sketch is sufficient) in side view. Our application engineers will determine the optimum gas springs and mounting points and calculate the ideal situation to satisfy your requirements.

You will receive a quotation showing the opening and closing forces and our recommended mounting points to suit your application.

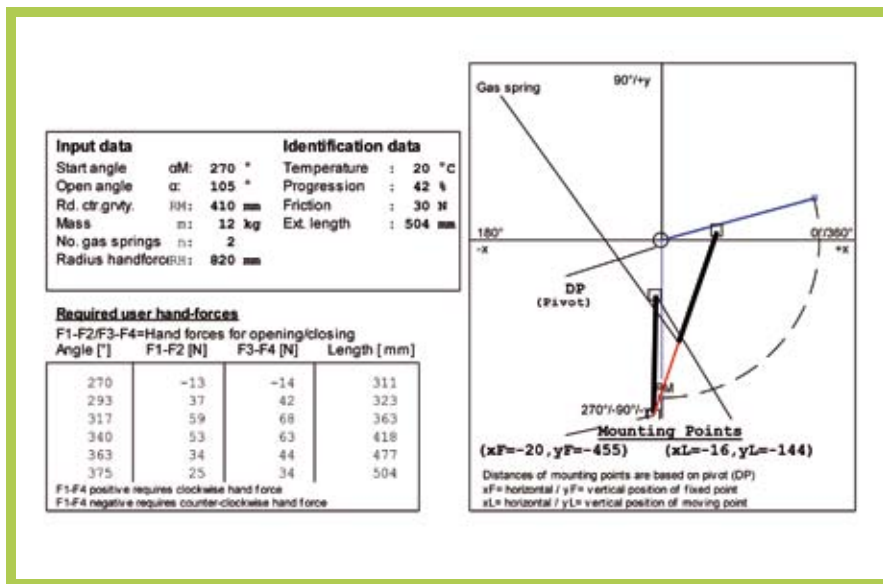

"Calculation offer with all required details for assembly!"



Safety Instructions

Gas springs are filled with pure nitrogen gas. Nitrogen is an inert gas that does not burn or explode and is not poisonous.

Please note!: the internal pressure of gas springs can be up to 300 bar. Do not attempt to open or modify them.

ACE gas springs will operate in surrounding temperatures from -20 °C to +80 °C. We can equip our springs with special seals to withstand temperatures as low as -45 °C or as high as +200 °C. Gas springs should not be placed over heat or in open fire!

Disposal/Recycling: Gas Springs consist mostly of metal and the metal could be recycled, but first the gas pressure must be removed. Please ask for our disposal recommendations which advise how to depressurize the gas springs and make them safe to recycle.

All gas springs are marked with the part number, the production date and a warning sign "Do not open high pressure". We are not responsible for any damages of any kind that arises due to goods that are not marked accordingly.

Gas springs should be installed with the piston rod downwards. This position ensures best damping quality. **Only ACE gas springs include an integrated grease chamber which allows for alternative mounting opportunities.**

Gas springs should not be exposed to tilting or side load forces during operation or whilst static (this can cause bending of the piston rod or early wear).

Gas springs are maintenance-free. **Do not grease or oil the piston rod.**

The piston rod must not be painted and should be protected against shocks, scratches and dirt. The cylinder should not be deformed as such damage would destroy the sealing system.

ACE gas springs can be stored in any position. Pressure lost through long storage is not to be expected. There are no known negative values, but there may be a sticking effect the first time you compress a spring. This may require a higher initial force to operate the gas spring for the first time (initial breakaway force).

The tolerance for the installation length is generally deemed to be ± 2 mm. If very high demands are placed on durability and stability, please avoid the combination of small diameter + long stroke + high force.

The filling tolerance is -20 N to 40 N or 5% to 7%.

Please send us a sketch with dimensions of your application!
Without this sketch we won't be able to calculate.

Push type Pull type

Input date

Gas spring fixing points

The fixed point of the frame and the moving point of the flap are critical for the optimum operation.

Therefore please attach a sketch of your application (a few lines with their dimensions are sufficient)!





Moving mass* m _____ kg
 Number of gas springs in parallel* n _____ pcs
 Number of movements* _____ /day
 Ambient temperature T _____ °C

If not shown by the sketch:

Radius of centre of gravity R_M _____ mm
 Radius of hand force R_H _____ mm
 Starting angle (0° to 360°) _____ °
 Opening angle (-360° to +360°) α _____ °
 (- = downwards, + = upwards)

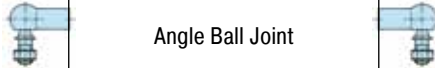
* Compulsory information

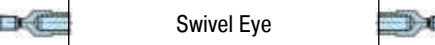
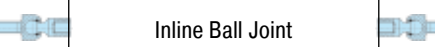
Desired Mounting Fittings

End Fitting		End Fitting
<input type="checkbox"/> A		<input type="checkbox"/> A
<input type="checkbox"/> B	Stud Thread	<input type="checkbox"/> B
<input type="checkbox"/> C		<input type="checkbox"/> C
<input type="checkbox"/> D	Angle Ball Joint	<input type="checkbox"/> D
<input type="checkbox"/> E		<input type="checkbox"/> E
<input type="checkbox"/> F	Clevis Fork	<input type="checkbox"/> F
<input type="checkbox"/> G		<input type="checkbox"/> G
<input type="checkbox"/> H	Swivel Eye	<input type="checkbox"/> H
<input type="checkbox"/> I		<input type="checkbox"/> I
<input type="checkbox"/> J	Inline Ball Joint	<input type="checkbox"/> J
<input type="checkbox"/> K		<input type="checkbox"/> K
<input type="checkbox"/> L	Ball Socket	<input type="checkbox"/> L

The end fittings are interchangeable.

e. g. -CE: C = Angle Ball Joint, E = Swivel Eye

Sketch: _____

Comments _____

Requirement per year _____

Machine type / reference _____

Sender

Company _____

Address _____

Internet _____

Dept. _____

Name _____

Telephone _____ Fax _____

E-Mail _____

**Please copy, complete and fax to ACE:
Fax +49-(0)2173-9226-89**

ACE industrial gas springs are maintenance-free and self-contained. They are available with body diameters from 8 mm up to 70 mm, and forces from 10 N up to 13 000 N ex. stock. **ACE gas springs offer a high service life with a wear-resistant coating on the piston rod. Also an integrated low friction bearing with grease chamber which provides a very low break away force (GS-19 to GS-40).** It allows them to be mounted in any orientation, although rod downwards is preferable if you want to take advantage of the built-in end position damping. The valve allows the force to be adjusted to your specific requirements. A wide variety of interchangeable end fittings makes installation easy and versatile. ACE gas springs are universally applicable wherever you have lifting and lowering. They remove the need for "muscle power" and provide controlled motion for lids, hoods, machine guards etc. The ACE selection software quickly specifies the correct gas spring for your individual application and we can deliver, usually within 24 hours.



"Force adjustable to your specific requirements – with gas valve ex. stock!"

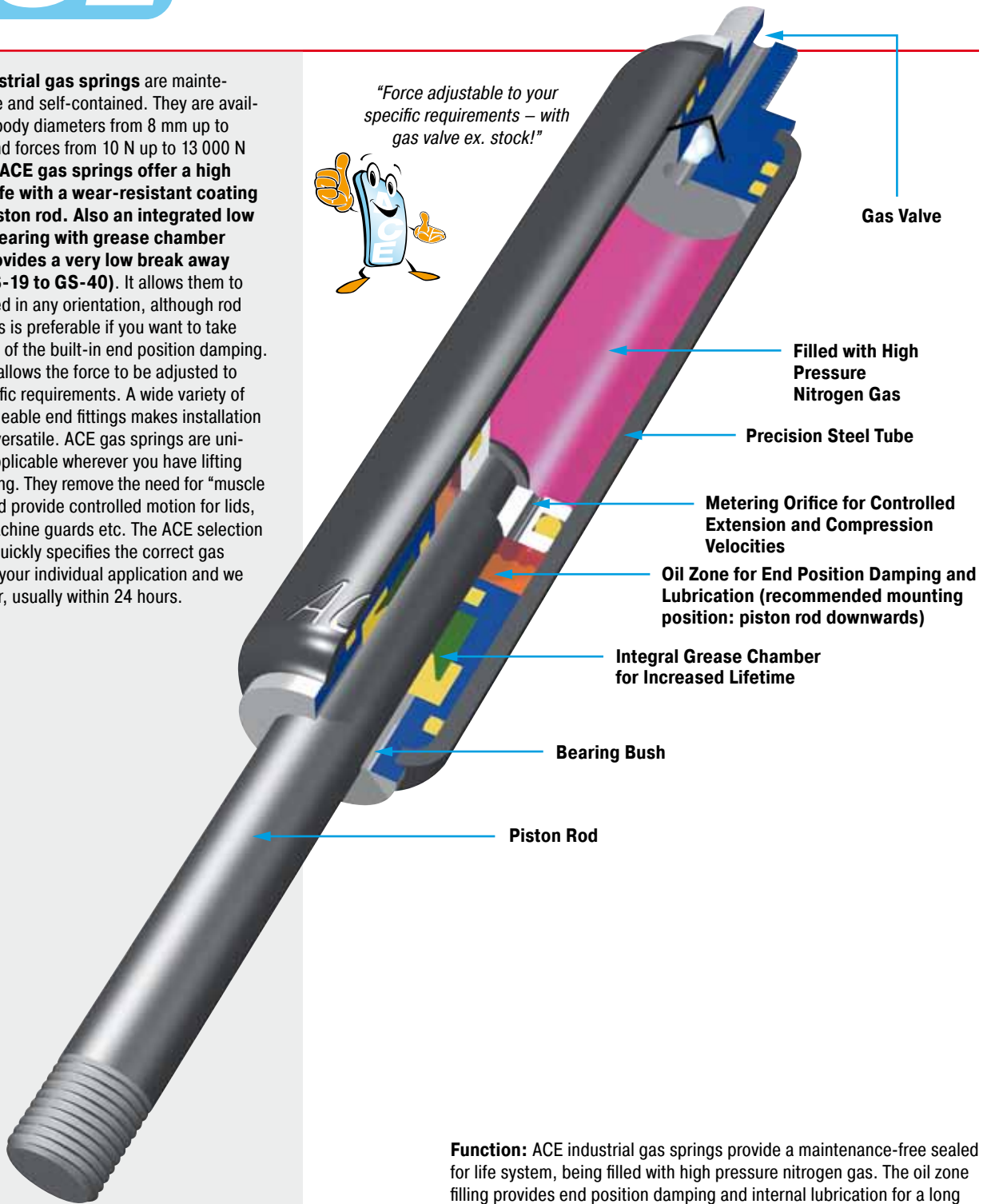

Function: ACE industrial gas springs provide a maintenance-free sealed for life system, being filled with high pressure nitrogen gas. The oil zone filling provides end position damping and internal lubrication for a long lifetime. On the extension stroke of the gas spring, for example when opening a car tailgate, the nitrogen gas flows through the metering orifice in the piston to provide a controlled opening speed and the oil zone provides damping at the fully open position to avoid impact damage. The gas spring should be mounted "rod down" for this damping to be effective. On closing the tailgate the gas spring helps support the weight. The metering orifice controls the extension and compression velocities of the gas spring.

Operating fluid: Nitrogen gas and oil

Mounting: In any position

Operating temperature range: -20 °C to 80 °C

On request: Without damping, extended length damping, special force curves, special lengths, alternative end fittings.



Extension Forces 10 N to 100 N
(when Piston Rod Compressed up to 130 N)

End Fitting

Standard Dimensions

End Fitting

A3,5

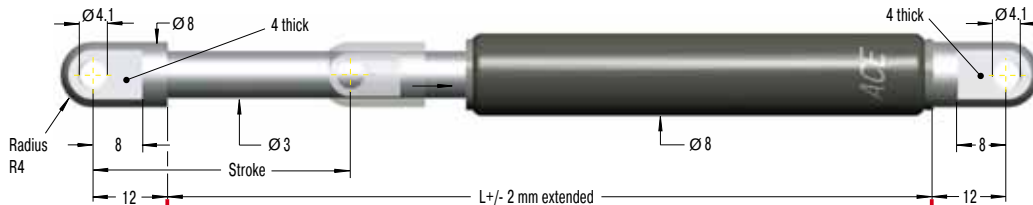

Eye A3,5
max. force 370 N

B3,5



Stud Thread B3,5

C3,5

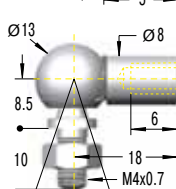

Angle Ball Joint C3,5
max. force 370 N

D3,5

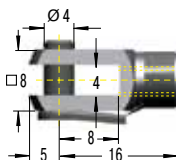

Clevis Fork D3,5
max. force 370 N

E3,5

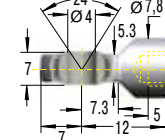

Swivel Eye E3,5
max. force 370 N

G3,5

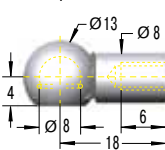

Ball Socket G3,5
max. force 370 N

Rod Shroud W3,5-8

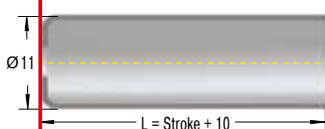

Dimensions

Type	Stroke mm	L extended
GS-8-20	20	72
GS-8-30	30	92
GS-8-40	40	112
GS-8-50	50	132
GS-8-60	60	152
GS-8-80	80	192

Ordering Example

GS-8-30-AC-30

Type (Push Type) _____
 Body Ø (8 mm) _____
 Stroke (30 mm) _____
 Piston Rod End Fitting A3,5 _____
 Body End Fitting C3,5 _____
 Nominal Force F₁ 30 N _____

The end fittings are interchangeable.
For mounting accessories see page 199.

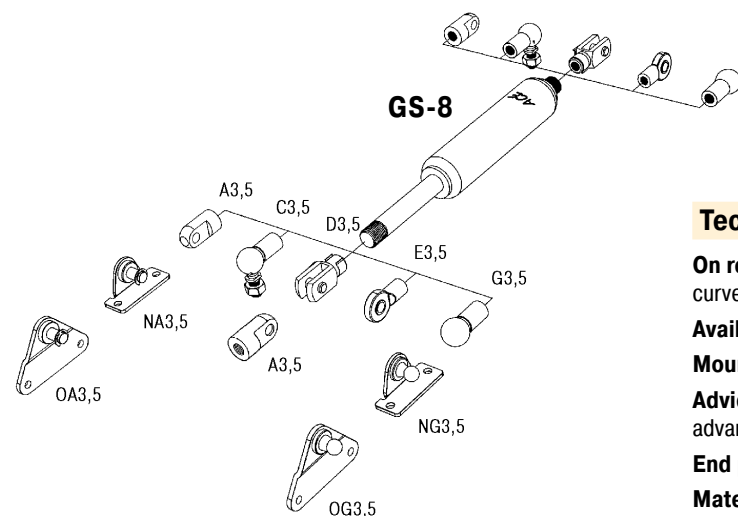

For mounting accessories see page 199.

Technical Data

On request: Without damping, extended length damping, special force curves, special lengths, alternative end fittings.

Available force range F₁ at 20 °C: 10 N to 100 N

Mounting: In any position

Advice: We recommend mounting with piston rod downwards to take advantage of the built-in end position damping.

End position damping length: Approx. 5 mm

Material: Body: Black coated steel. Piston rod: Stainless steel (1.4305). End fittings: Zinc plated steel.

Progression: Approx. 28 %, F₂ max. 130 N

End Fitting

Standard Dimensions

End Fitting

A3,5

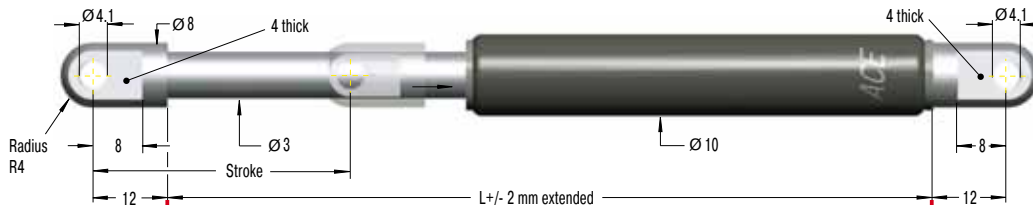

Eye A3,5
max. force 370 N

B3,5



Stud Thread B3,5

C3,5

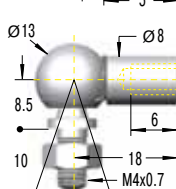

Angle Ball Joint C3,5
max. force 370 N

D3,5

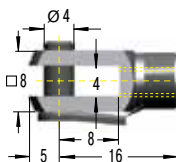

Clevis Fork D3,5
max. force 370 N

E3,5

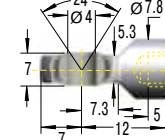

Swivel Eye E3,5
max. force 370 N

G3,5

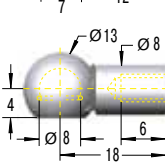

Ball Socket G3,5
max. force 370 N

Rod Shroud W3,5-10

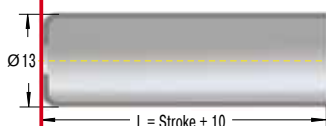

Dimensions

Type	Stroke mm	L extended
GS-10-20	20	72
GS-10-30	30	92
GS-10-40	40	112
GS-10-50	50	132
GS-10-60	60	152
GS-10-80	80	192

Ordering Example

GS-10-80-AC-60

Type (Push Type) _____
 Body Ø (10 mm) _____
 Stroke (80 mm) _____
 Piston Rod End Fitting A3,5 _____
 Body End Fitting C3,5 _____
 Nominal Force F₁ 60 N _____

The end fittings are interchangeable.
For mounting accessories see page 199.

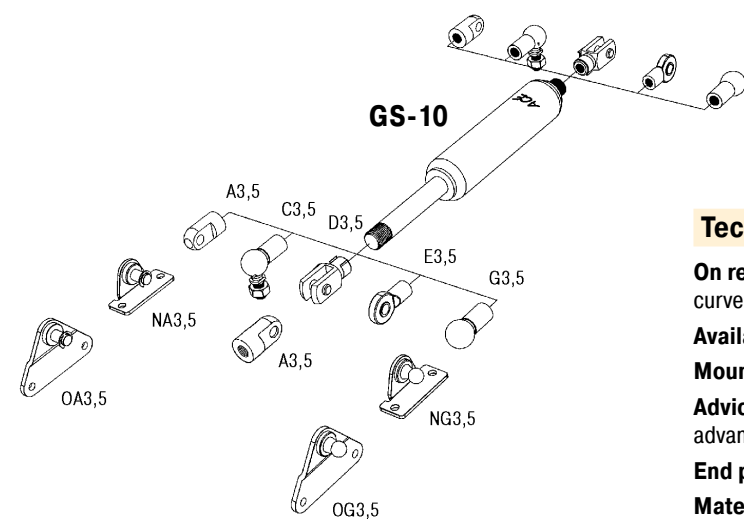

For mounting accessories see page 199.

Technical Data

On request: Without damping, extended length damping, special force curves, special lengths, alternative end fittings.

Available force range F₁ at 20 °C: 10 N to 100 N

Mounting: In any position

Advice: We recommend mounting with piston rod downwards to take advantage of the built-in end position damping.

End position damping length: Approx. 5 mm

Material: Body: Black coated steel. Piston rod: Stainless steel (1.4305). End fittings: Zinc plated steel.

Progression: Approx. 20%, F₂ max. 120 N

Extension Forces 10 N to 180 N
(when Piston Rod Compressed up to 225 N)

End Fitting

Standard Dimensions

End Fitting

A3,5

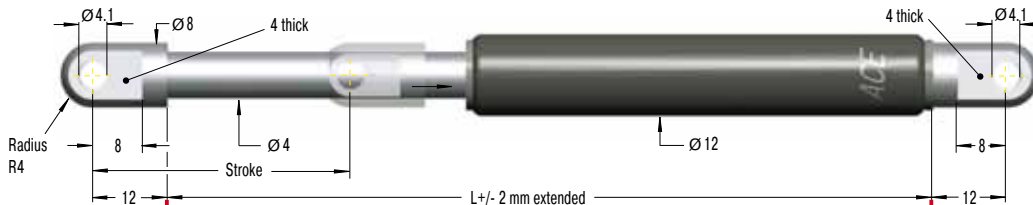

Eye A3,5
max. force 370 N

B3,5



Stud Thread B3,5

C3,5

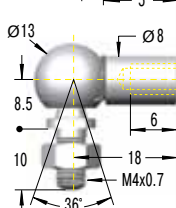

Angle Ball Joint C3,5
max. force 370 N

D3,5

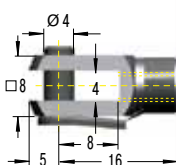

Clevis Fork D3,5
max. force 370 N

E3,5

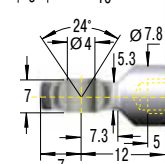

Swivel Eye E3,5
max. force 370 N

G3,5

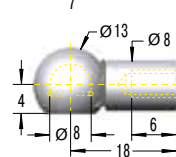

Ball Socket G3,5
max. force 370 N

Rod Shroud W3,5-12

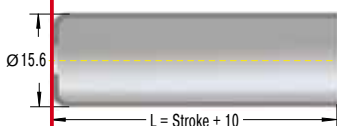

Dimensions

Type	Stroke mm	L extended	F ₁ max. N
GS-12-20	20	72	180
GS-12-30	30	92	180
GS-12-40	40	112	180
GS-12-50	50	132	180
GS-12-60	60	152	180
GS-12-80	80	192	150
GS-12-100	100	232	150
GS-12-120	120	272	120
GS-12-150	150	332	100

Ordering Example

GS-12-100-AA-30

Type (Push Type) _____
 Body Ø (12 mm) _____
 Stroke (100 mm) _____
 Piston Rod End Fitting A3,5 _____
 Body End Fitting A3,5 _____
 Nominal Force F₁ 30 N _____

The end fittings are interchangeable.
For mounting accessories see page 199.

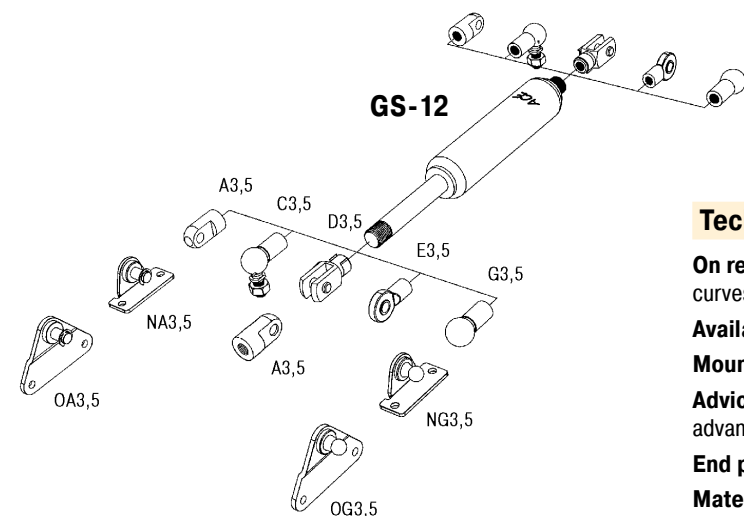

For mounting accessories see page 199.

Technical Data

On request: Without damping, extended length damping, special force curves, special lengths, alternative end fittings.

Available force range F₁ at 20 °C: 10 N to 180 N

Mounting: In any position

Advice: We recommend mounting with piston rod downwards to take advantage of the built-in end position damping.

End position damping length: Approx. 10 mm

Material: Body: Black coated steel. Piston rod: Stainless steel (1.4305). End fittings: Zinc plated steel.

Progression: Approx. 25%, F₂ max. 225 N

End Fitting

Standard Dimensions

End Fitting

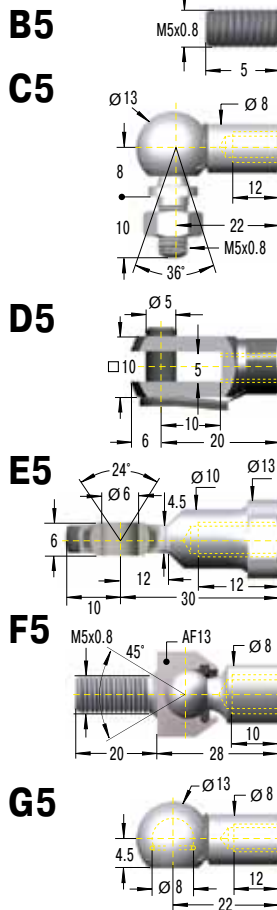
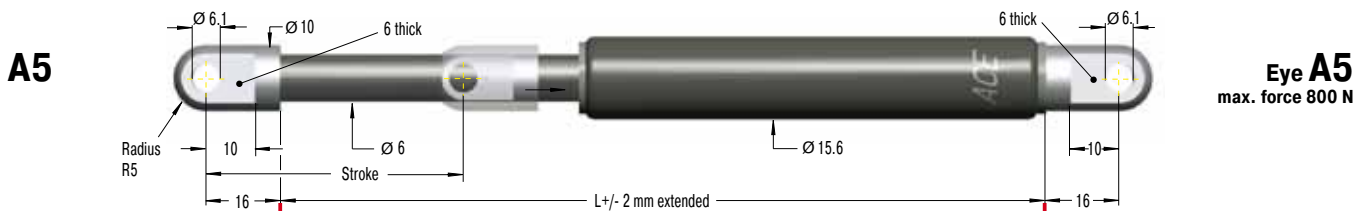

Dimensions		
Type	Stroke mm	L extended
GS-15-20	20	67
GS-15-40	40	107
GS-15-50	50	127
GS-15-60	60	147
GS-15-80	80	187
GS-15-100	100	227
GS-15-120	120	267
GS-15-150	150	327
GS-15-200	200	427

Ordering Example **GS-15-150-AC-150**

Type (Push Type) _____
 Body Ø (15.6 mm) _____
 Stroke (150 mm) _____
 Piston Rod End Fitting A5 _____
 Body End Fitting C5 _____
 Nominal Force F₁ 150 N _____

The end fittings are interchangeable.
For mounting accessories see page 199.

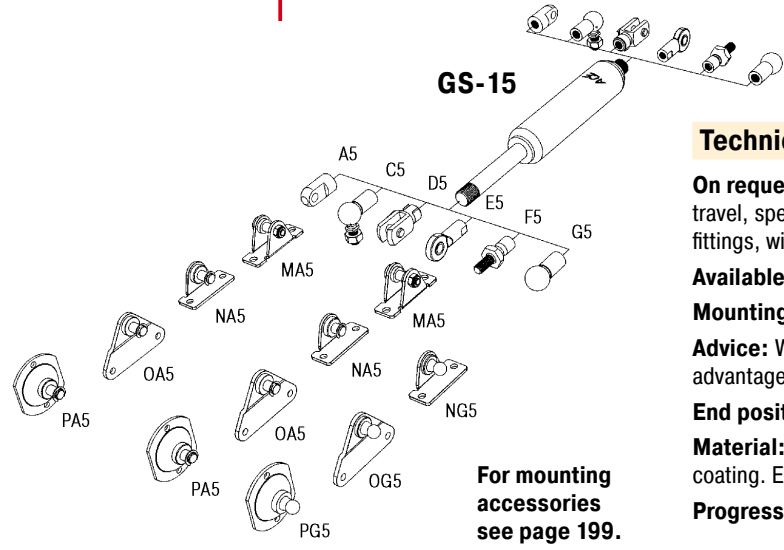
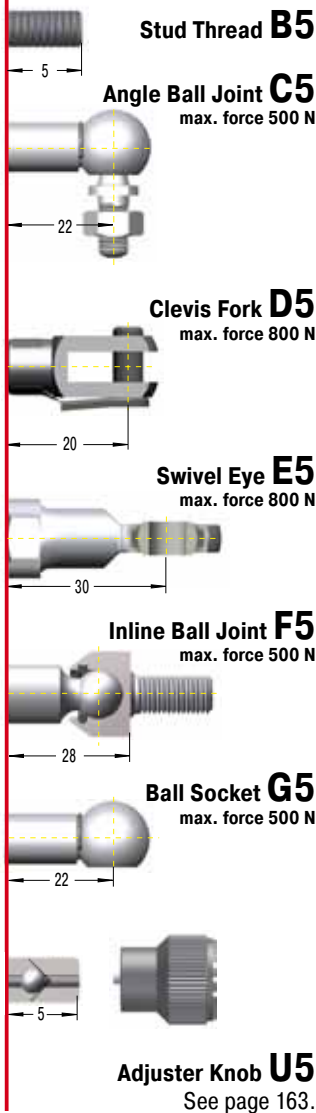
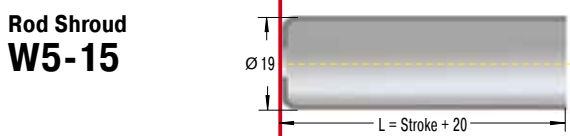

For mounting accessories see page 199.

Technical Data

On request: Without damping, increased damping action at end of travel, special force curves, special lengths, strokes, alternative end fittings, wiper, stainless steel (see pages 179 to 186).

Available force range F₁ at 20 °C: 40 N to 400 N

Mounting: In any position

Advice: We recommend mounting with piston rod downwards to take advantage of the built-in end position damping.

End position damping length: Approx. 10 mm

Material: Body: Black coated steel. Piston rod: With wear-resistant coating. End fittings: Zinc plated steel.

Progression: Approx. 27%, F₂ max. 500 N

Issue 6.2011 Specifications subject to change

End Fitting

Standard Dimensions

End Fitting

A8



Eye A8
max. force 3000 N

B8



Stud Thread B8

C8

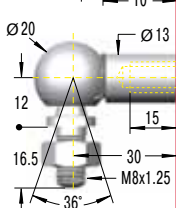

Angle Ball Joint C8
max. force 1200 N

D8

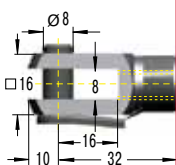

Clevis Fork D8
max. force 3000 N

E8

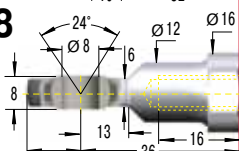

Swivel Eye E8
max. force 3000 N

F8

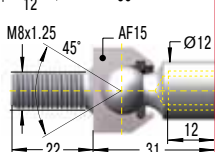

Inline Ball Joint F8
max. force 1200 N

G8

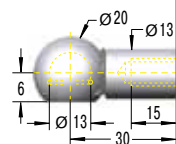

Ball Socket G8
max. force 1200 N

Rod Shroud W8-19

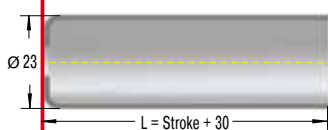

Dimensions

Type	Stroke mm	L extended
GS-19-50	50	164
GS-19-100	100	264
GS-19-150	150	364
GS-19-200	200	464
GS-19-250	250	564
GS-19-300	300	664

Ordering Example

GS-19-150-AC-600

Type (Push Type) _____
 Body Ø (19 mm) _____
 Stroke (150 mm) _____
 Piston Rod End Fitting A8 _____
 Body End Fitting C8 _____
 Nominal Force F₁ 600 N _____

The end fittings are interchangeable.
For mounting accessories see page 200.

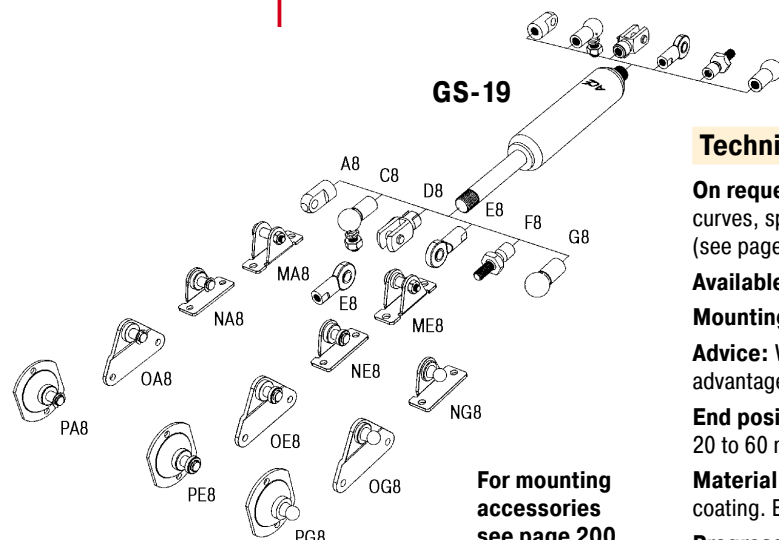

For mounting accessories see page 200.

Technical Data

On request: Without damping, standard length damping, special force curves, special lengths, alternative end fittings, wiper, stainless steel (see pages 179 to 186).

Available force range F₁ at 20 °C: 50 N to 700 N

Mounting: In any position

Advice: We recommend mounting with piston rod downwards to take advantage of the built-in end position damping.

End position damping length: Strong end position damping approx. 20 to 60 mm (depending on the stroke) and slow extension speed.

Material: Body: Black coated steel. Piston rod: With wear-resistant coating. End fittings: Zinc plated steel.

Progression: Approx. 36% to 42%, F₂ max. 995 N

End Fitting

Standard Dimensions

End Fitting

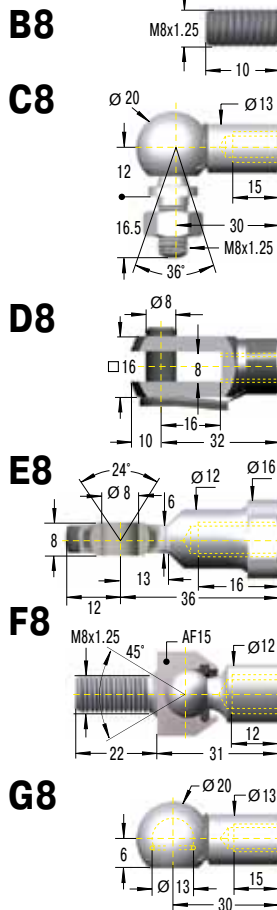
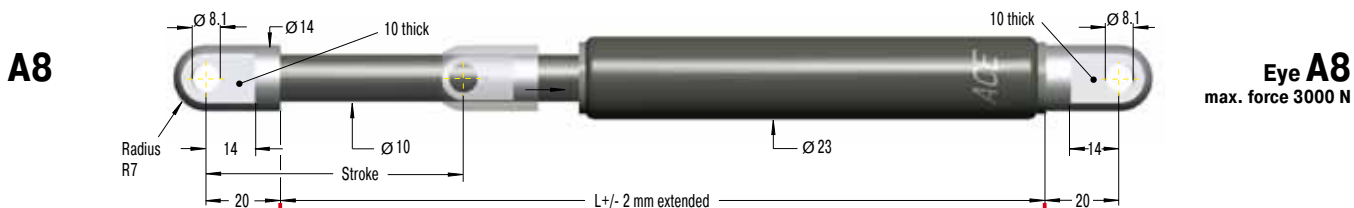

Dimensions		
Type	Stroke mm	L extended
GS-22-50	50	164
GS-22-100	100	264
GS-22-150	150	364
GS-22-200	200	464
GS-22-250	250	564
GS-22-300	300	664
GS-22-350	350	764
GS-22-400	400	864
GS-22-450	450	964
GS-22-500	500	1 064
GS-22-550	550	1 164
GS-22-600	600	1 264
GS-22-650	650	1 364
GS-22-700	700	1 464

Ordering Example
GS-22-150-AE-800
 Type (Push Type) _____
 Body Ø (23 mm) _____
 Stroke (150 mm) _____
 Piston Rod End Fitting A8 _____
 Body End Fitting E8 _____
 Nominal Force F₁ 800 N _____

The end fittings are interchangeable.
For mounting accessories see page 200.

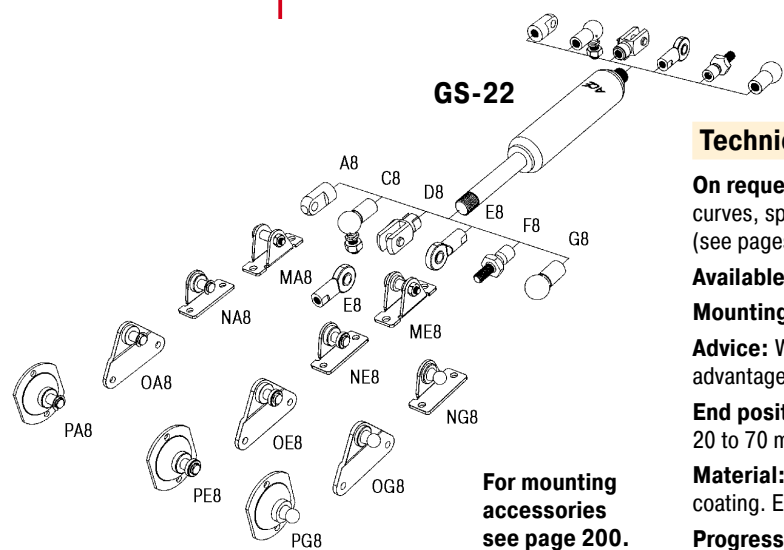
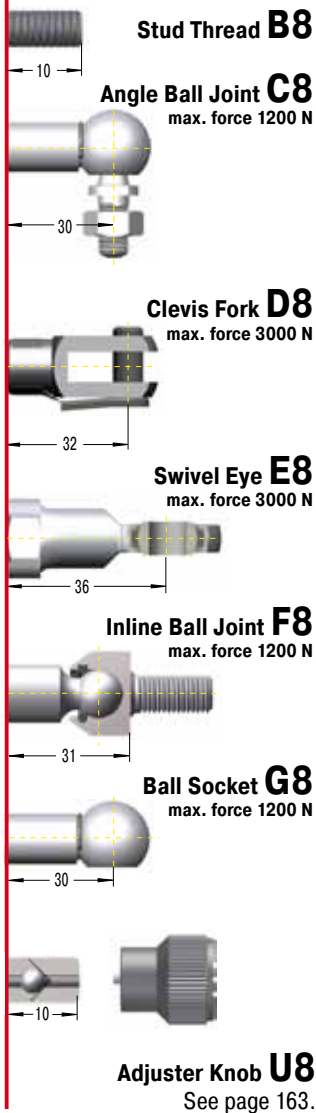
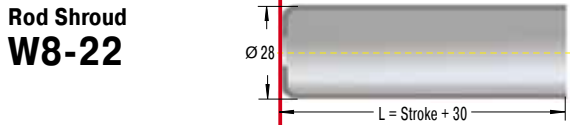

For mounting accessories see page 200.

Technical Data

On request: Without damping, standard length damping, special force curves, special lengths, alternative end fittings, wiper, stainless steel (see pages 179 to 186).
Available force range F₁ at 20 °C: 80 N to 1300 N
Mounting: In any position
Advice: We recommend mounting with piston rod downwards to take advantage of the built-in end position damping.
End position damping length: Strong end position damping approx. 20 to 70 mm (depending on the stroke) and slow extension speed.
Material: Body: Black coated steel. Piston rod: With wear-resistant coating. End fittings: Zinc plated steel.
Progression: Approx. 39% to 50%, F₂ max. 1950 N

Issue 6.2011 Specifications subject to change

End Fitting

Standard Dimensions

End Fitting

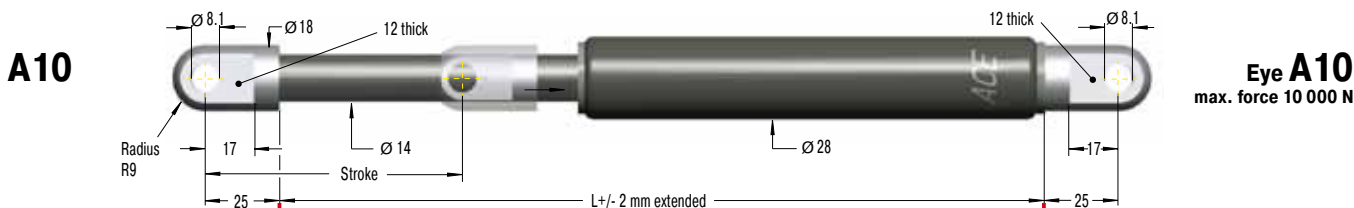

B10



Stud Thread B10

C10

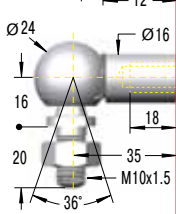

Angle Ball Joint C10

max. force 1800 N

D10

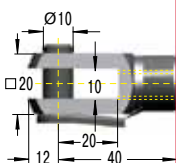

Clevis Fork D10

max. force 10 000 N

E10

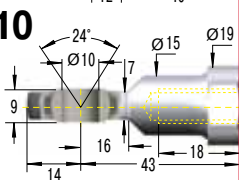

Swivel Eye E10

max. force 10 000 N

F10

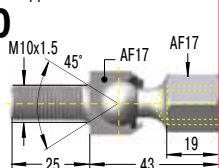

Inline Ball Joint F10

max. force 1800 N

Rod Shroud W10-28

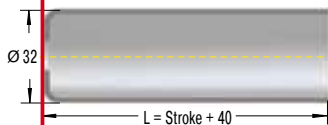

Dimensions

Type	Stroke mm	L extended
GS-28-100	100	262
GS-28-150	150	362
GS-28-200	200	462
GS-28-250	250	562
GS-28-300	300	662
GS-28-350	350	762
GS-28-400	400	862
GS-28-450	450	962
GS-28-500	500	1 062
GS-28-550	550	1 162
GS-28-600	600	1 262
GS-28-650	650	1 362
GS-28-700	700	1 462
GS-28-750	750	1 562

Ordering Example

GS-28-150-EE-1200

Type (Push Type) _____
 Body Ø (28 mm) _____
 Stroke (150 mm) _____
 Piston Rod End Fitting E10 _____
 Body End Fitting E10 _____
 Nominal Force F₁ 1200 N _____

The end fittings are interchangeable.
For mounting accessories see page 200.

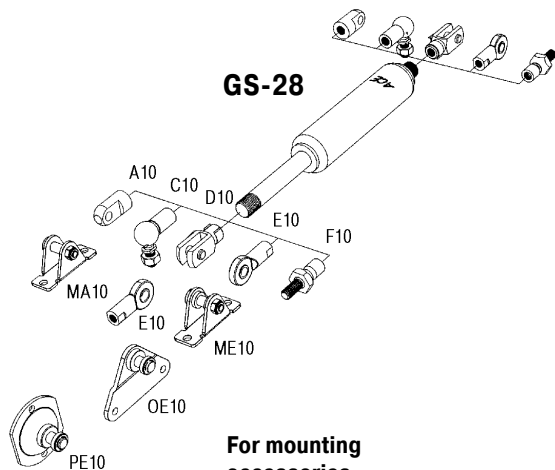

For mounting accessories see page 200.

Technical Data

On request: Without damping, standard length damping, special force curves, special lengths, alternative end fittings, wiper, stainless steel (see pages 179 to 186).

Available force range F₁ at 20 °C: 150 N to 2500 N

Mounting: In any position

Advice: We recommend mounting with piston rod downwards to take advantage of the built-in end position damping.

End position damping length: Strong end position damping approx. 30 to 70 mm (depending on the stroke) and slow extension speed.

Material: Body: Black coated steel. Piston rod: With wear-resistant coating. End fittings: Zinc plated steel.

Progression: Approx. 60% to 95%, F₂ max. 4875 N

End Fitting

Standard Dimensions

End Fitting

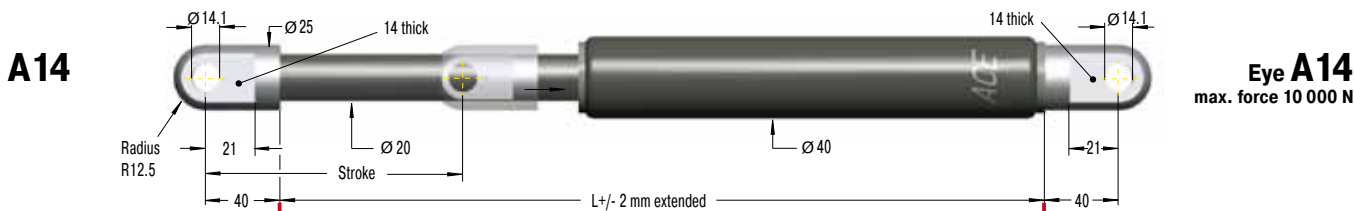

A14

Eye A14
max. force 10 000 N

B14

Stud Thread B14

C14

Angle Ball Joint C14
max. force 3200 N

D14

Clevis Fork D14
max. force 10 000 N

E14

Swivel Eye E14
max. force 10 000 N

F14

Inline Ball Joint F14
max. force 3200 N

Rod Shroud W14-40

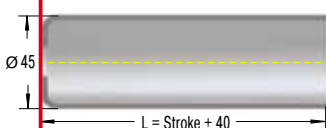

Dimensions

Type	Stroke mm	L extended
GS-40-100	100	317
GS-40-150	150	417
GS-40-200	200	517
GS-40-300	300	717
GS-40-400	400	917
GS-40-500	500	1 117
GS-40-600	600	1 317
GS-40-800	800	1 717
GS-40-1000	1 000	2 117

Ordering Example

GS-40-150-DD-3500

Type (Push Type) _____
 Body Ø (40 mm) _____
 Stroke (150 mm) _____
 Piston Rod End Fitting D14 _____
 Body End Fitting D14 _____
 Nominal Force F₁ 3500 N _____

The end fittings are interchangeable.
For mounting accessories see page 201.

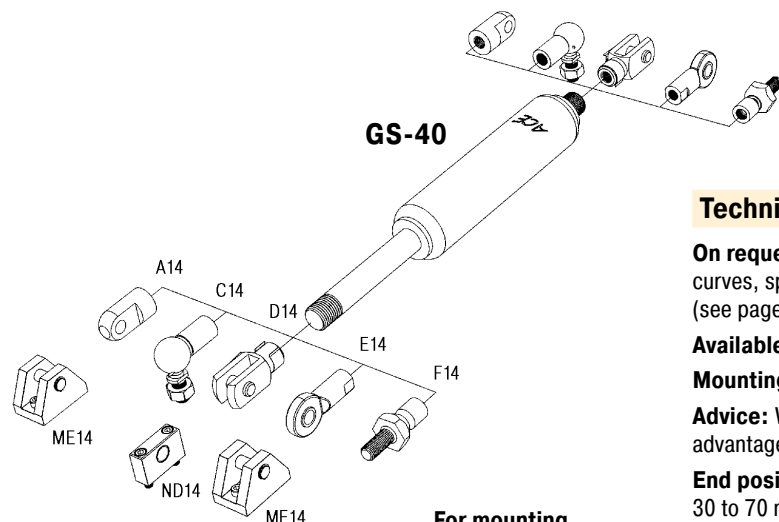

For mounting accessories see page 201.

Technical Data

On request: Without damping, standard length damping, special force curves, special lengths, alternative end fittings, wiper, stainless steel (see pages 179 to 186).

Available force range F₁ at 20 °C: 500 N to 5000 N

Mounting: In any position

Advice: We recommend mounting with piston rod downwards to take advantage of the built-in end position damping.

End position damping length: Strong end position damping approx. 30 to 70 mm (depending on the stroke) and slow extension speed.

Material: Body: Black coated steel. Piston rod: With wear-resistant coating. End fittings: Zinc plated steel.

Progression: Approx. 47 % to 53 %, F₂ max. 7650 N

End Fitting

Standard Dimensions

End Fitting

B24

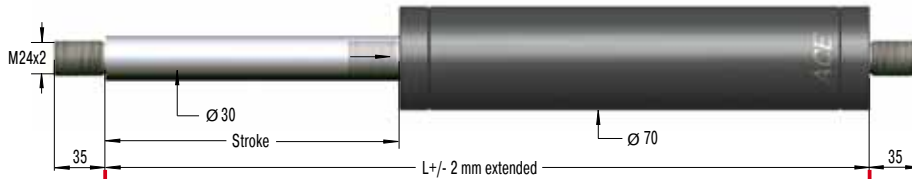

Stud Thread **B24**

D24

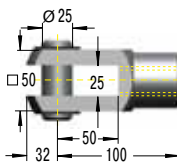

Clevis Fork **D24**
max. force 50 000 N

E24

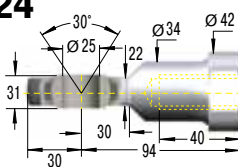

Swivel Eye **E24**
max. force 50 000 N

Dimensions

Type	Stroke mm	L extended
GS-70-100	100	320
GS-70-200	200	520
GS-70-300	300	720
GS-70-400	400	920
GS-70-500	500	1 120
GS-70-600	600	1 320
GS-70-700	700	1 520
GS-70-800	800	1 720

Ordering Example

GS-70-200-EE-8000

Type (Push Type) _____
 Body Ø (70 mm) _____
 Stroke (200 mm) _____
 Piston Rod End Fitting E24 _____
 Body End Fitting E24 _____
 Nominal Force F_1 8000 N _____

The end fittings are interchangeable.
 For mounting accessories see page 201.
 Standard gas spring with valve.

Rod Shroud
W24-70

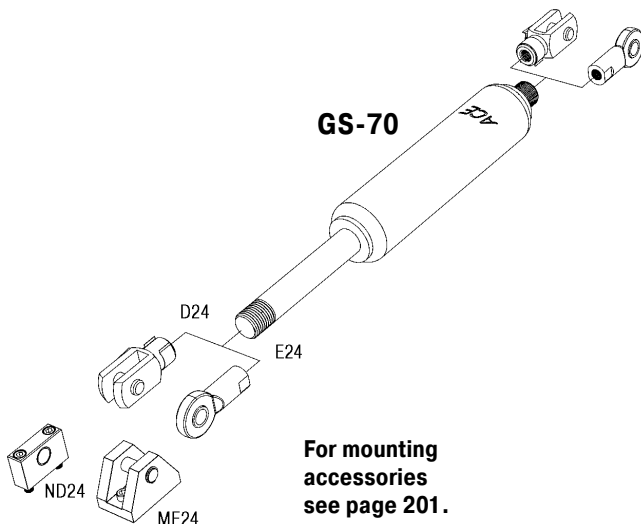
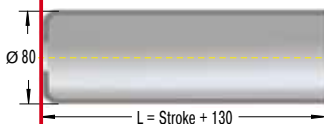

For mounting
accessories
see page 201.

Technical Data

On request: Without damping, extended length damping, special force curves, special lengths, alternative end fittings, wiper, stainless steel.

Available force range F_1 at 20 °C: 2000 N to 13 000 N

Mounting: In any position

Advice: We recommend mounting with piston rod downwards to take advantage of the built-in end position damping.

End position damping length: Approx. 10 mm

Material: Body: Black coated steel or zinc plated steel. Piston rod: Hard chrome plated. End fittings: Zinc plated steel.

Progression: Approx. 25 %, F_2 max. 16 250 N

ACE offers **tandem gas springs** specially for heavy flaps and hoods with a large opening angle. These are characterised by a high initial force and low end force. The tandem gas springs have two pressure tubes with different extension forces and progression curves, and are therefore able to cover two force ranges. **The tandem gas springs are designed specifically for your application.** The force ranges are matched exactly to each other and adjusted to the required application dynamics. Tandem gas springs are maintenance-free and ready to install. The comprehensive range of fitting parts ensures easy installation.

"Reduce the need for muscle power for comfortably opening heavy flaps!"



NEW

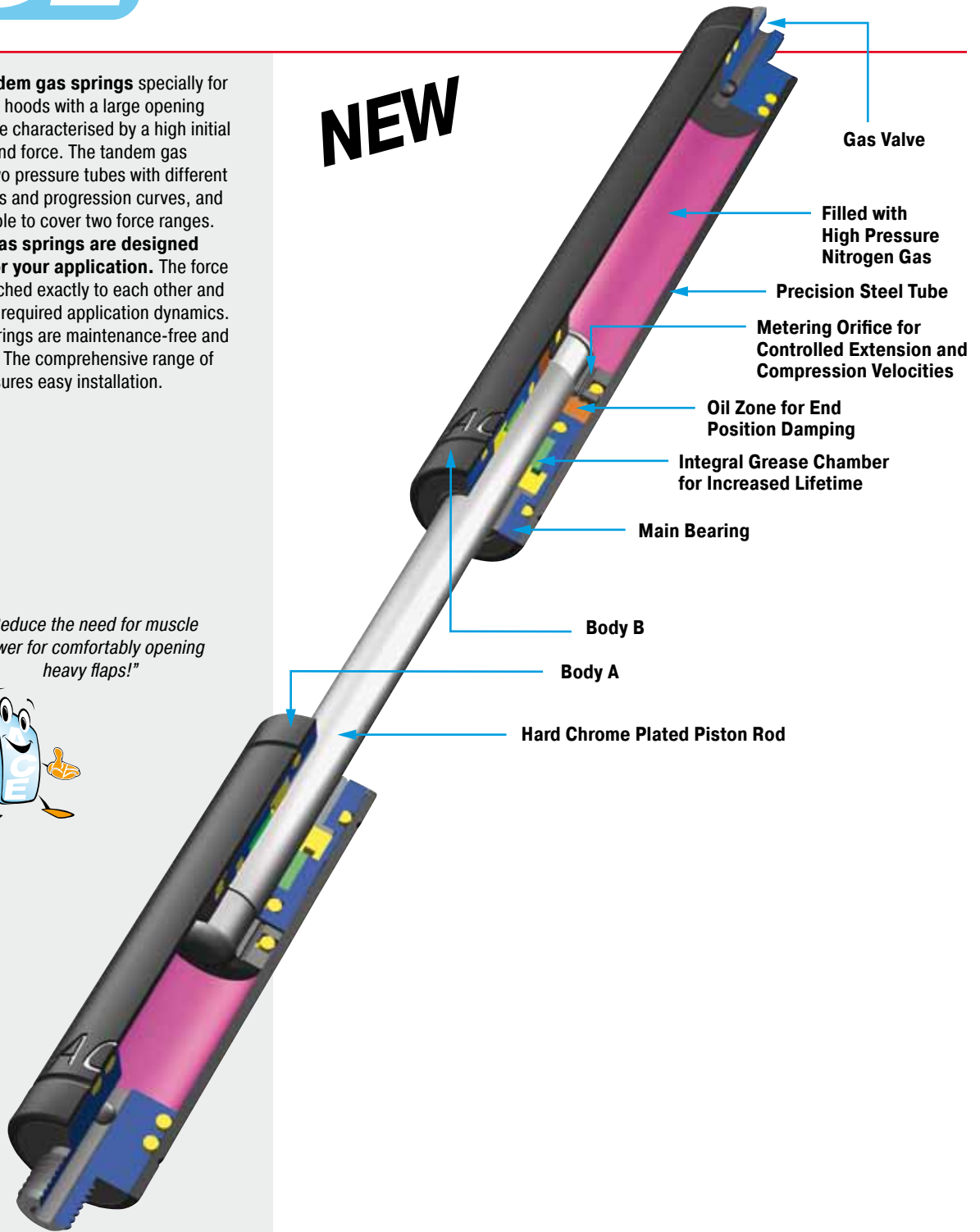

Operating fluid: Nitrogen gas and oil

Material: Piston rod: Hard chrome plated steel. Bodies and end fittings: Zinc plated steel.

Mounting: According to calculation. Please adopt the mounting points determined by ACE.

Operating temperature range: -20 °C to 80 °C

On request: Material 1.4301/1.4305, AISI 304/303 (V2A) and material 1.4404/1.4571, AISI 316L/316Ti (V4A).



End Fitting

Standard Dimensions

End Fitting

A14

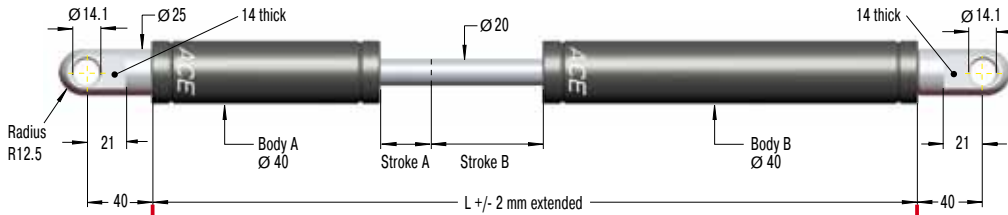

Eye A14
max. force 10 000 N

B14

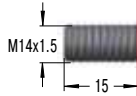

Stud Thread B14

D14

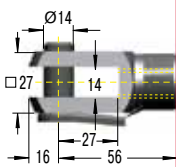

Clevis Fork D14
max. force 10 000 N

E14

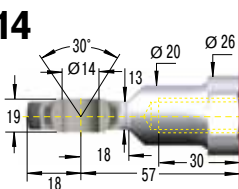

Swivel Eye E14
max. force 10 000 N

Dimensions

Type	Stroke A mm	Stroke B mm	L extended
GST-40-50-100	50	100	485
GST-40-50-150	50	150	585
GST-40-50-200	50	200	685
GST-40-70-250	70	250	825
GST-40-70-300	70	300	925
GST-40-70-350	70	350	1 025
GST-40-70-400	70	400	1 125

Ordering Example

GST-40-50-150-AD-900N-2500N

Type (Tandem Gas Spring) _____
 Body Ø (40 mm) _____
 Stroke A (50 mm) _____
 Stroke B (150 mm) _____
 Body A End Fitting, A14 _____
 Body B End Fitting, D14 _____
 Nominal Force Body A, 900 N _____
 Nominal Force Body B, 2500 N _____

The end fittings are interchangeable.
 These gas springs are tailored to the relevant application and are therefore not available ex stock.
 For mounting accessories see page 201.

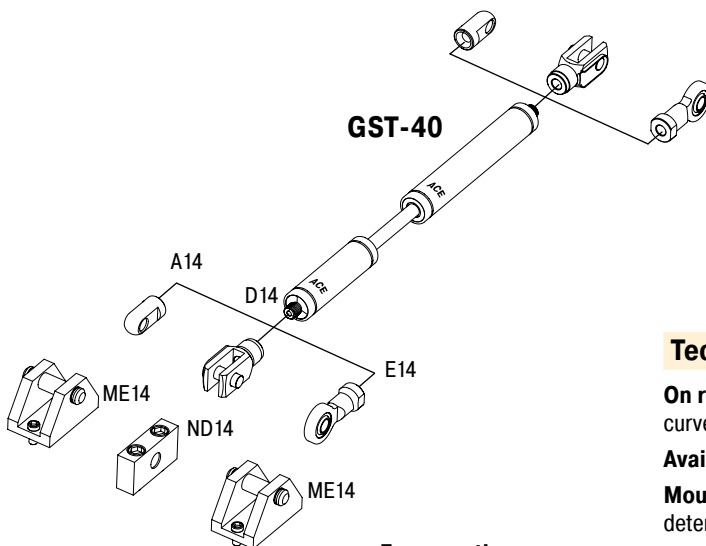

For mounting accessories see page 201.

Technical Data

On request: Without damping, standard length damping, special force curves, special lengths, alternative end fittings, wiper.

Available force range F_1 at 20 °C: 300 N to 5000 N

Mounting: According to calculation. Please adopt the mounting points determined by ACE.

End position damping length: Strong end position damping approx. 30 to 70 mm (depending on the stroke) and slow extension speed.

Material: Piston rod: Hard chrome plated. Bodies and accessories: Zinc plated steel.

Progression: According to calculation relating to your application.

Stainless steel gas springs (push type)
 Material 1.4301/1.4305, AISI 304/303 (V2A),
 Material 1.4404/1.4571, AISI 316L/316Ti (V4A)

In addition to the comprehensive range of industrial gas springs with valve, ACE also offers a wide range of industrial gas springs made of stainless steel with body diameters from 8 mm to 70 mm. This high-quality version is also available on request in all stroke lengths and possible extension forces. The comprehensive range of fitting parts ensures easy installation and makes the gas springs universal in use. Stainless steel industrial gas springs are used everywhere that raising and lowering is required. Due to their special properties, **non-rusting and low magnetism**, they are the preferred equipment for medical and clean-room technology, the foodstuffs industry, electronics and shipbuilding sector.

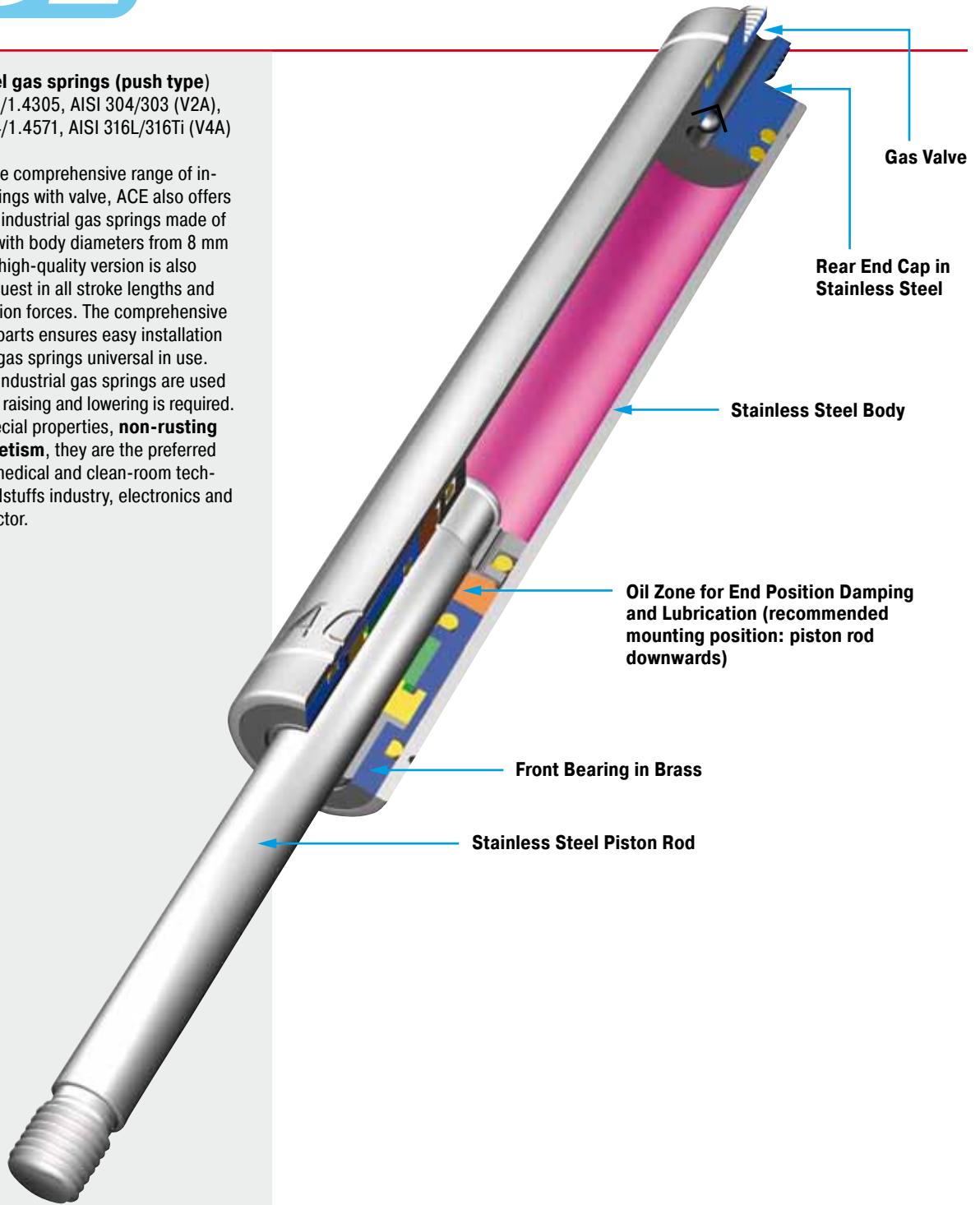

Operating fluid: Nitrogen gas and oil

Material: Piston rod, body and end fittings: Material 1.4301/1.4305, AISI 304/303 (V2A) or material 1.4404/1.4571, AISI 316L/316Ti (V4A).

Mounting: In any position

Advice: We recommend mounting with piston rod downwards to take advantage of the built-in end position damping.

Operating temperature range:
 -20 °C to 80 °C

On request: Without damping, strong end position damping, special force curves, wiper, special lengths, alternative end fittings.



End Fitting

Standard Dimensions

End Fitting

B3,5

M3.5x0.6

Stud Thread **B3,5**

A3,5-V4A

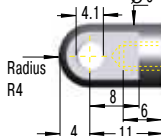

Eye
A3,5-V4A
max. force 370 N

C3,5-V4A

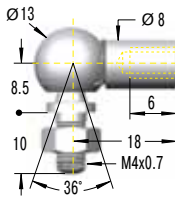

Angle Ball Joint
C3,5-V4A
max. force 370 N

D3,5-V4A

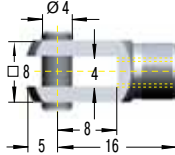

Clevis Fork
D3,5-V4A
max. force 370 N

G3,5-V4A

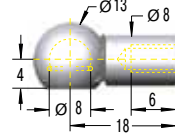

Ball Socket
G3,5-V4A
max. force 370 N

Rod Shroud
W3,5-8-V4A

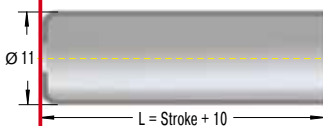

Adjuster Knob **U3,5**
See page 163.

Dimensions

Type	Stroke mm	L extended
GS-8-20-V4A	20	72
GS-8-30-V4A	30	92
GS-8-40-V4A	40	112
GS-8-50-V4A	50	132
GS-8-60-V4A	60	152
GS-8-80-V4A	80	192

Ordering Example

GS-8-30-AC-30-V4A

Type (Push Type) _____
 Body Ø (8 mm) _____
 Stroke (30 mm) _____
 Piston Rod End Fitting A3,5-V4A _____
 Body End Fitting C3,5-V4A _____
 Nominal Force F₁ 30 N _____
 Indicated by K.-No. on delivery _____

The end fittings are interchangeable.
For mounting accessories see page 202.

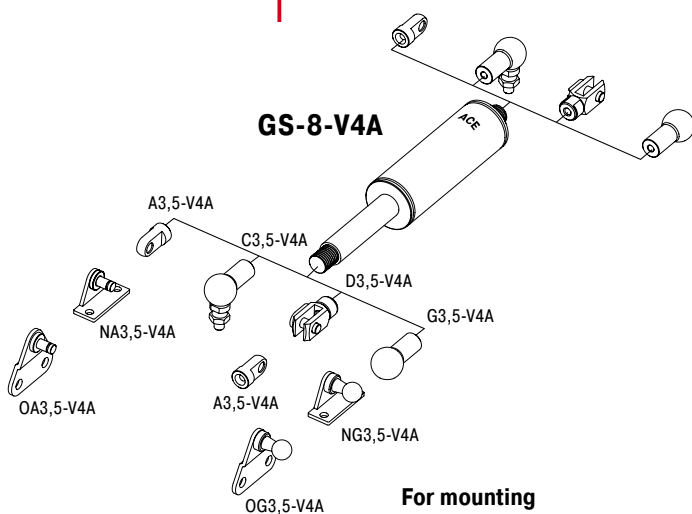

For mounting
accessories
see page 202.

Technical Data

On request: Without damping, increased end position damping, special force curves, special end fittings.

Available force range F₁ at 20 °C: 25 N to 100 N

Mounting: In any position

Advice: We recommend mounting with piston rod downwards to take advantage of the built-in end position damping.

End position damping length: approx. 5 mm

Material: Piston rod, body and end fittings: Material 1.4404/1.4571, AISI 316L/316Ti (V4A).

Progression: approx. 27%, F₂ max. 130 N

End Fitting

Standard Dimensions

End Fitting

B3,5

A3,5-V4A

C3,5-V4A

D3,5-V4A

G3,5-V4A

Rod Shroud W3,5-12-V4A

Dimensions		
Type	Stroke mm	L extended
GS-12-20-V4A	20	72
GS-12-30-V4A	30	92
GS-12-40-V4A	40	112
GS-12-50-V4A	50	132
GS-12-60-V4A	60	152
GS-12-80-V4A	80	192
GS-12-100-V4A	100	232
GS-12-120-V4A	120	272
GS-12-150-V4A	150	332

Ordering Example

GS-12-100-AA-30-V4A

Type (Push Type) _____

Body Ø (12 mm) _____

Stroke (100 mm) _____

Piston Rod End Fitting A3,5-V4A _____

Body End Fitting A3,5-V4A _____

Nominal Force F₁ 30 N _____

Indicated by K.-No. on delivery _____

The end fittings are interchangeable.
For mounting accessories see page 202.

Stud Thread **B3,5**

Eye A3,5-V4A
max. force 370 N

Angle Ball Joint C3,5-V4A
max. force 370 N

Clevis Fork D3,5-V4A
max. force 370 N

Ball Socket G3,5-V4A
max. force 370 N

Adjuster Knob U3,5
See page 163.

Issue 6.2011 Specifications subject to change

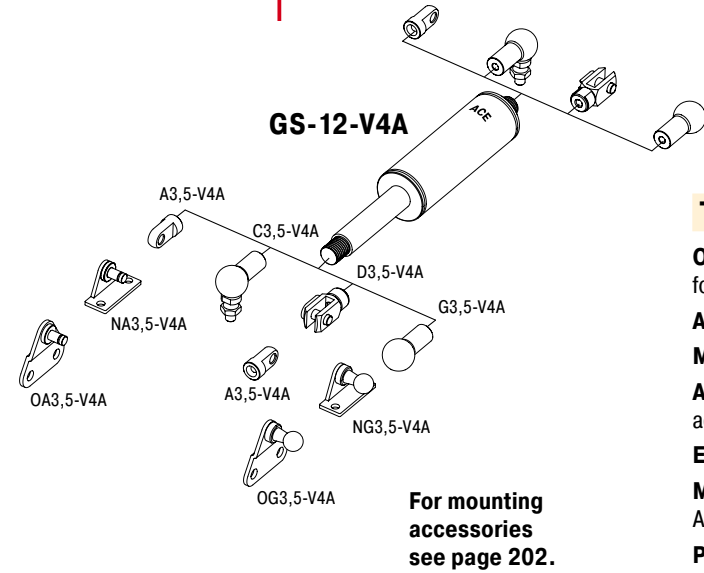

Technical Data

On request: Without damping, increased end position damping, special force curves, special end fittings.

Available force range F₁ at 20 °C: 25 N to 200 N

Mounting: In any position

Advice: We recommend mounting with piston rod downwards to take advantage of the built-in end position damping.

End position damping length: approx. 10 mm

Material: Piston rod, body and end fittings: Material 1.4404/1.4571, AISI 316L/316Ti (V4A).

Progression: approx. 18%, F₂ max. 235 N

Extension Forces 40 N to 400 N
(when Piston Rod Compressed up to 490 N)

End Fitting

Standard Dimensions

End Fitting

B5

A5-VA

C5-VA

D5-VA

E5-VA

G5-VA

Rod Shroud W5-15-VA

Dimensions

Type	Stroke mm	L extended
GS-15-20-VA	20	74
GS-15-40-VA	40	114
GS-15-50-VA	50	134
GS-15-60-VA	60	154
GS-15-80-VA	80	194
GS-15-100-VA	100	234
GS-15-120-VA	120	274
GS-15-150-VA	150	334

Ordering Example

Type (Push Type) _____ ↑↑↑↑↑↑↑↑↑↑

Body Ø (15.6 mm) _____ ↑↑↑↑↑↑↑↑↑↑

Stroke (150 mm) _____ ↑↑↑↑↑↑↑↑↑↑

Piston Rod End Fitting A5-VA _____ ↑↑↑↑↑↑↑↑↑↑

Body End Fitting C5-VA _____ ↑↑↑↑↑↑↑↑↑↑

Nominal Force F₁ 150 N _____ ↑↑↑↑↑↑↑↑↑↑

Indicated by K.-No. on delivery _____ ↑↑↑↑↑↑↑↑↑↑

GS-15-150-AC-150-VA

The end fittings are interchangeable.
Strokes also available up to 300 mm.
For mounting accessories see page 202.

Stud Thread B5

Eye A5-VA
max. force 490 N

Angle Ball Joint C5-VA
max. force 430 N

Clevis Fork D5-VA
max. force 490 N

Swivel Eye E5-VA
max. force 490 N

Ball Socket G5-VA
max. force 430 N

Adjuster Knob U5
See page 163.

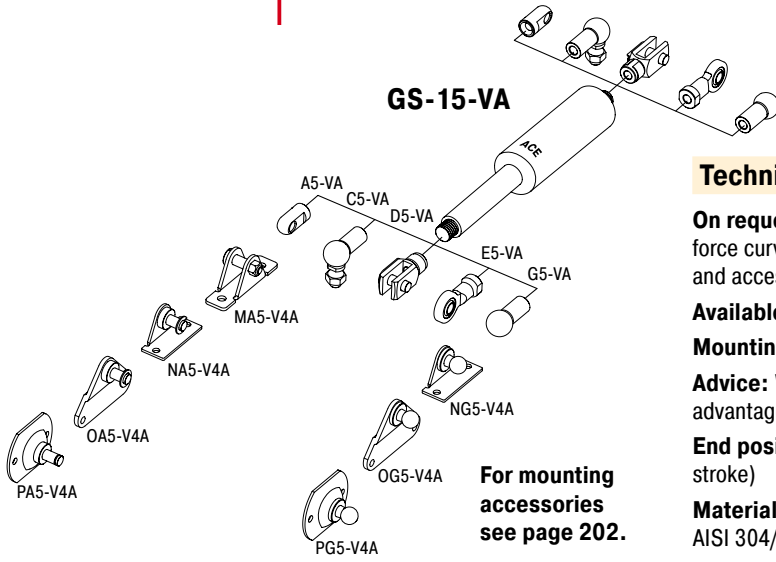

Technical Data

On request: Without damping, increased end position damping, special force curves, special lengths, alternative end fittings, wiper. Gas springs and accessories: Material 1.4404/1.4571, AISI 316L/316Ti (V4A).

Available force range F₁ at 20 °C: 40 N to 400 N

Mounting: In any position

Advice: We recommend mounting with piston rod downwards to take advantage of the built-in end position damping.

End position damping length: Approx. 20 mm (depending on the stroke)

Material: Piston rod, body and end fittings: Material 1.4301/1.4305, AISI 304/303 (V2A).

Progression: Approx. 34%, F₂ max. 490 N

Extension Forces 50 N to 700 N
(when Piston Rod Compressed up to 910 N)

End Fitting

Standard Dimensions

End Fitting

B8

A8-VA

C8-VA

D8-VA

E8-VA

G8-VA

Rod Shroud W8-19-VA

Dimensions

Type	Stroke mm	L extended
GS-19-50-VA	50	164
GS-19-100-VA	100	264
GS-19-150-VA	150	364
GS-19-200-VA	200	464
GS-19-250-VA	250	564
GS-19-300-VA	300	664

Ordering Example

GS-19-150-AC-600-VA

Type (Push Type) _____

Body Ø (19 mm) _____

Stroke (150 mm) _____

Piston Rod End Fitting A8-VA _____

Body End Fitting C8-VA _____

Nominal Force F₁ 600 N _____

Indicated by K.-No. on delivery _____

The end fittings are interchangeable.
Strokes also available up to 500 mm.
For mounting accessories see page 203.

Stud Thread B8

Eye A8-VA
max. force 1560 N

Angle Ball Joint C8-VA
max. force 1140 N

Clevis Fork D8-VA
max. force 1560 N

Swivel Eye E8-VA
max. force 1560 N

Ball Socket G8-VA
max. force 1140 N

Adjuster Knob U8
See page 163.

Issue 6.2011 Specifications subject to change

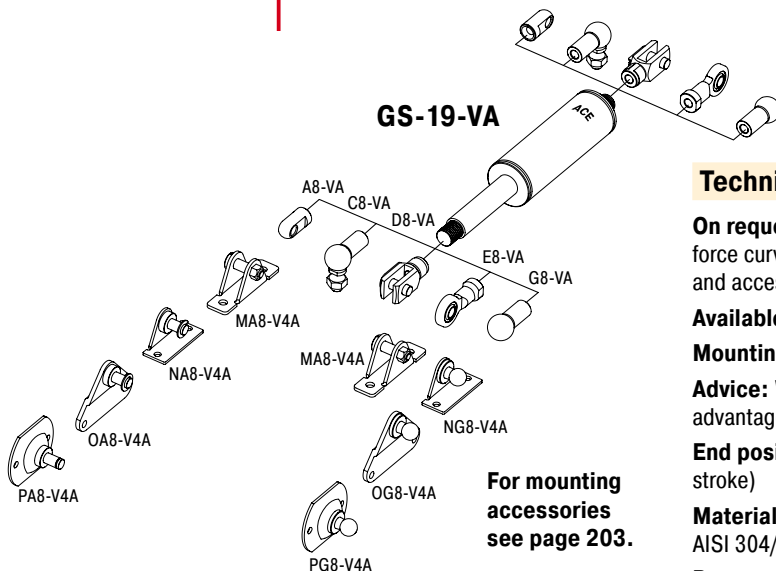

For mounting accessories see page 203.

Technical Data

On request: Without damping, increased end position damping, special force curves, special lengths, alternative end fittings, wiper. Gas springs and accessories: Material 1.4404/1.4571, AISI 316L/316Ti (V4A).

Available force range F₁ at 20 °C: 50 N to 700 N

Mounting: In any position

Advice: We recommend mounting with piston rod downwards to take advantage of the built-in end position damping.

End position damping length: Approx. 20 mm (depending on the stroke)

Material: Piston rod, body and end fittings: Material 1.4301/1.4305, AISI 304/303 (V2A).

Progression: Approx. 33%, F₂ max. 910 N

Extension Forces 150 N to 2500 N
(when Piston Rod Compressed up to 3800 N)

End Fitting

Standard Dimensions

End Fitting

B10

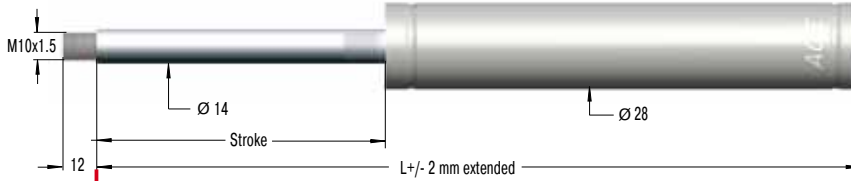

Stud Thread B10

A10-VA

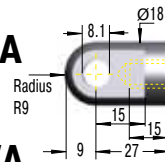

Eye A10-VA max. force 3800 N

C10-VA

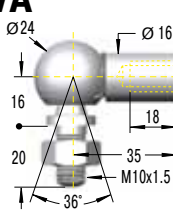

Angle Ball Joint C10-VA max. force 1750 N

D10-VA

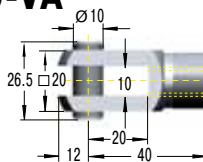

Clevis Fork D10-VA max. force 3800 N

E10-VA

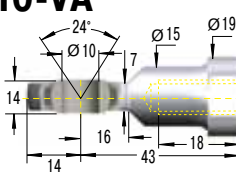

Swivel Eye E10-VA max. force 3800 N

Dimensions

Type	Stroke mm	L extended
GS-28-100-VA	100	262
GS-28-150-VA	150	362
GS-28-200-VA	200	462
GS-28-250-VA	250	562
GS-28-300-VA	300	662
GS-28-350-VA	350	762
GS-28-400-VA	400	862
GS-28-450-VA	450	962
GS-28-500-VA	500	1 062
GS-28-550-VA	550	1 162
GS-28-600-VA	600	1 262
GS-28-650-VA	650	1 362

Ordering Example

GS-28-150-EE-1200-VA

Type (Push Type) _____
 Body Ø (28 mm) _____
 Stroke (150 mm) _____
 Piston Rod End Fitting E10-VA _____
 Body End Fitting E10-VA _____
 Nominal Force F₁ 1200 N _____
 Indicated by K.-No. on delivery _____

The end fittings are interchangeable.
 Strokes also available up to 750 mm.
 For mounting accessories see page 203.

Rod Shroud W10-28-VA

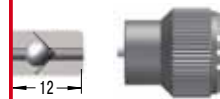
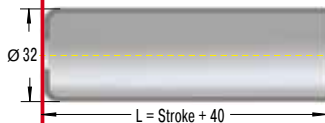

Adjuster Knob U10-VA See page 163.

Issue 6.2011 Specifications subject to change

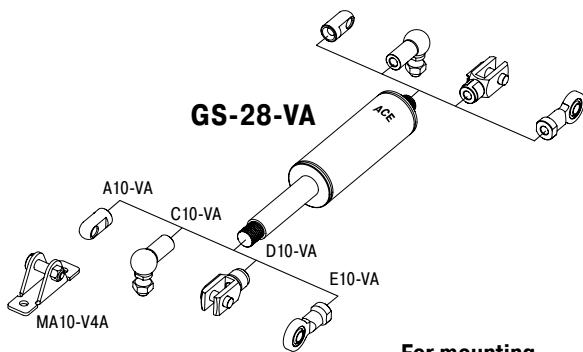

For mounting accessories see page 203.

Technical Data

On request: Without damping, increased end position damping, special force curves, special lengths, alternative end fittings, wiper. Gas springs and accessories: Material 1.4404/1.4571, AISI 316L/316Ti (V4A).

Available force range F₁ at 20 °C: 150 N to 2500 N

Mounting: In any position

Advice: We recommend mounting with piston rod downwards to take advantage of the built-in end position damping.

End position damping length: Approx. 20 mm (depending on the stroke)

Material: Piston rod, body and end fittings: Material 1.4301/1.4305, AISI 304/303 (V2A).

Progression: Approx. 52%, F₂ max. 3800 N

End Fitting

Standard Dimensions

End Fitting

B14

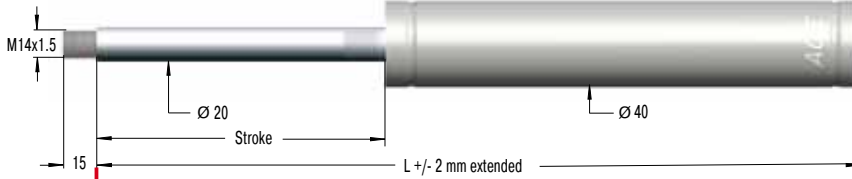

Stud Thread B14

A14-VA

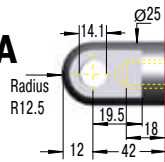

Dimensions

Type	Stroke mm	L extended
GS-40-100-VA	100	317
GS-40-150-VA	150	417
GS-40-200-VA	200	517
GS-40-300-VA	300	717
GS-40-400-VA	400	917
GS-40-500-VA	500	1 117
GS-40-600-VA	600	1 317

Eye A14-VA max. force 7000 N

C14-VA

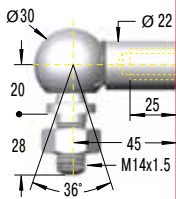

Angle Ball Joint C14-VA max. force 3200 N

D14-VA

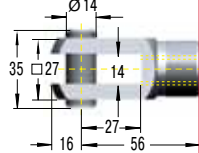

Clevis Fork D14-VA max. force 7000 N

E14-VA

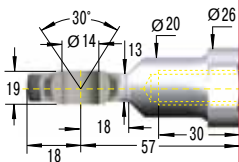

Swivel Eye E14-VA max. force 7000 N

Rod Shroud W14-40-VA

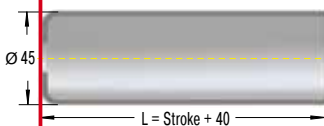

Ordering Example

GS-40-150-DD-3500-VA

Type (Push Type) _____
 Body Ø (40 mm) _____
 Stroke (150 mm) _____
 Piston Rod End Fitting D14-VA _____
 Body End Fitting D14-VA _____
 Nominal Force F₁ 3500 N _____
 Indicated by K.-No. on delivery _____

The end fittings are interchangeable.
 Strokes also available up to 1000 mm.
 For mounting accessories see page 204.

Adjuster Knob U14-VA

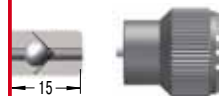

Adjuster Knob U14-VA See page 163.

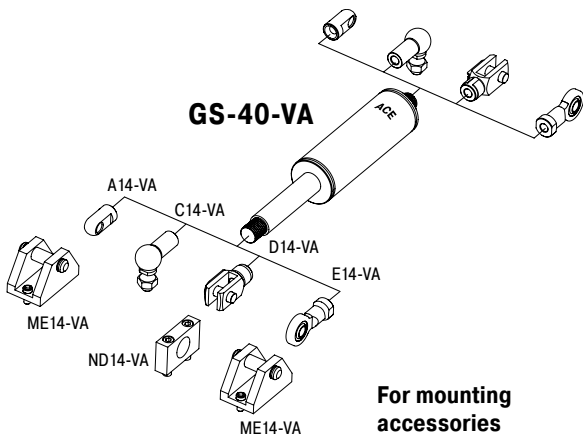

For mounting
 accessories
 see page 204.

Technical Data

On request: Without damping, increased end position damping, special force curves, special lengths, alternative end fittings, wiper. Gas springs and accessories: Material 1.4404/1.4571, AISI 316L/316Ti (V4A).

Available force range F₁ at 20 °C: 500 N to 5000 N

Mounting: In any position

Advice: We recommend mounting with piston rod downwards to take advantage of the built-in end position damping.

End position damping length: Approx. 30 mm (depending on the stroke)

Material: Piston rod, body and end fittings: Material 1.4301/1.4305, AISI 304/303 (V2A).

Progression: Approx. 40%, F₂ max. 7000 N

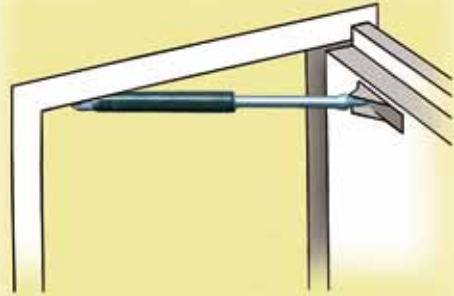

Doors open and close safely

ACE industrial gas springs make opening and closing doors of rescue helicopters easier.

The maintenance-free, sealed systems are installed in the access doors of helicopters of the type EC 135. There, they allow the crew to enter or exit the helicopter quickly, thus contributing to enhanced safety.

The **GS-19-300-CC** gas springs provide a defined retraction speed and secure engagement of the door lock. The integrated end position damper allows gentle closing of the door and saves wear and tear on the valuable, lightweight material.



Industrial gas springs: For safe entry and exit

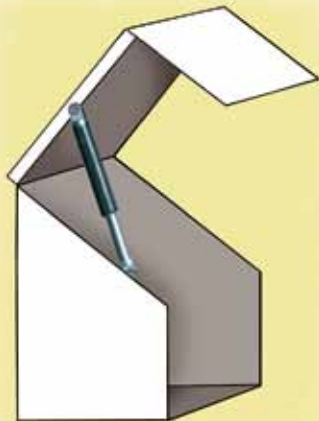

Protection under the hood

ACE industrial gas springs prevent injuries during maintenance work on harvesting machines.

The blades of corn pickers are arranged under plastic hoods, which assure proper material flow within the machine. For maintenance purposes, the hoods, weighing about 7 kg, must be lifted up. To protect maintenance personnel from injury by falling hoods, they are kept in the open position by industrial gas springs of the type **GS-22-250-DD**.

Another advantage they offer is their stability under rough operating conditions due to their wear-resistant coating on the piston rod and the coated housing.



Enhanced protection: Industrial gas springs secure heavy hoods

Industrial traction gas springs are maintenance-free and ready to install. They are available ex-stock with body diameters from 15 mm to 40 mm and forces from 30 N to 5000 N with valve. **ACE traction gas springs offer a long service life due to the hard-chromed piston rod and integral sliding bearing.** They can be installed in any position. The traction force can be subsequently adjusted by means of the valve. The comprehensive range of fitting parts ensures easy installation and makes the traction gas springs universal in use. They supply the muscle force and enable the controlled raising and lowering of covers, hoods, flaps etc. With the free ACE calculation service, the traction gas springs are designed with mounting points to fit the individual application, and can be delivered ex-stock as express deliveries within 24 hours.

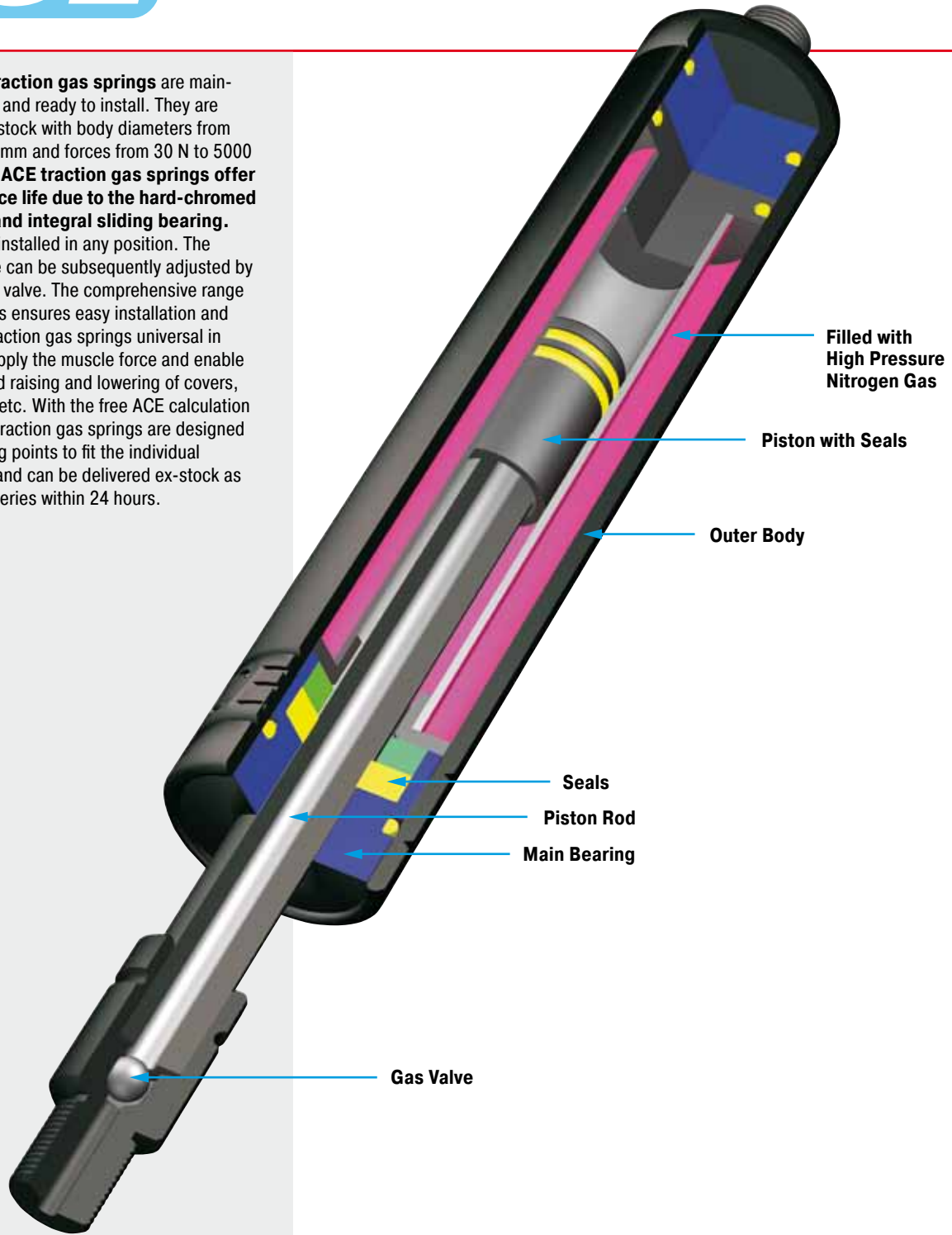

Function: ACE industrial traction gas springs are maintenance-free, closed systems, which are filled with pressurised nitrogen gas. Compared to the push type, ACE traction gas springs work in the reverse way. The piston rod is retracted by the gas pressure in the cylinder. The surface of the piston ring between the piston rod and the inner tube determines the force of the gas spring. Traction gas springs are always mounted with the stroke fully compressed.

Operating fluid: Nitrogen gas

Mounting: In any position

Operating temperature range:
-20 °C to 80 °C

On request: Special force curves, special lengths, alternative seals and end fittings.



Traction (Pull) Forces 50 N to 300 N
(when Piston Rod Extended up to 370 N)

NEW

End Fitting

Standard Dimensions

End Fitting

A3,5

Radius R4

Ø4.1

Ø8

4 thick

8

Ø4

12

Stroke

Ø15

L +/- 2 mm retracted

12

Eye A3,5
max. force 370 N

Stud Thread B3,5

Angle Ball Joint C3,5
max. force 370 N

Clevis Fork D3,5
max. force 370 N

Swivel Eye E3,5
max. force 370 N

Ball Socket G3,5
max. force 370 N

Adjuster Knob U3,5
See page 163.

Dimensions		
Type	Stroke mm	L retracted
GZ-15-20	20	87
GZ-15-40	40	107
GZ-15-50	50	117
GZ-15-60	60	127
GZ-15-80	80	147
GZ-15-100	100	167
GZ-15-120	120	187
GZ-15-150	150	217

Ordering Example **GZ-15-150-AC-150**

Type (Pull Type) _____

Body Ø (15 mm) _____

Stroke (150 mm) _____

Piston Rod End Fitting A5 _____

Body End Fitting C5 _____

Traction Force F₁ 150 N _____

The end fittings are interchangeable and must be positively secured by the customer to prevent unscrewing (i.e. Loctite). For mounting accessories see page 199.

Issue 6.2011 Specifications subject to change

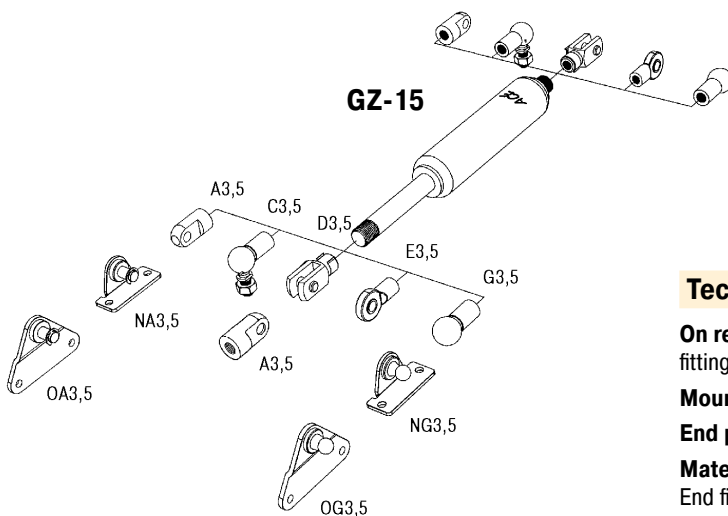

For mounting accessories see page 199.

Technical Data

On request: Special force curves, special lengths, alternative end fittings, rod shroud.

Mounting: In any position. Install mechanical stop in extended position.

End position damping length: Without damping

Material: Piston rod: Hard chrome plated. Body: black coated. End fittings: Zinc plated steel.

Progression: approx. 23 %, F₂ max. 370 N

Available traction force range F₁ at 20 °C: 50 N to 300 N

Note: Lifetime approx. 2000 m

Traction (Pull) Forces 30 N to 300 N
(when Piston Rod Extended up to 330 N)

End Fitting

Standard Dimensions

End Fitting



B8

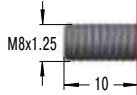

Stud Thread B8

C8

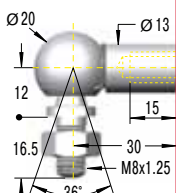

Angle Ball Joint C8

max. force 1200 N

D8

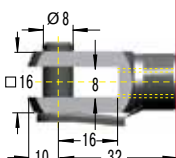

Clevis Fork D8

max. force 3000 N

E8

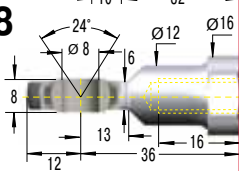

Swivel Eye E8

max. force 3000 N

G8

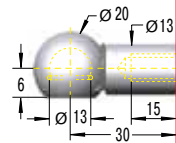

Ball Socket G8

max. force 1200 N

Dimensions

Type	Stroke mm	L retracted
GZ-19-30	30	112
GZ-19-50	50	132
GZ-19-100	100	182
GZ-19-150	150	232
GZ-19-200	200	282
GZ-19-250	250	332

Ordering Example

GZ-19-150-AC-250

Type (Pull Type) _____
 Body Ø (19 mm) _____
 Stroke (150 mm) _____
 Piston Rod End Fitting A8 _____
 Body End Fitting C8 _____
 Traction Force F₁ 250 N _____

The end fittings are interchangeable and must be positively secured by the customer to prevent unscrewing (i.e. Loctite).
 For mounting accessories see page 200.

Rod Shroud W8-19

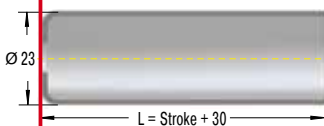

Adjuster Knob UZ8

See page 163.

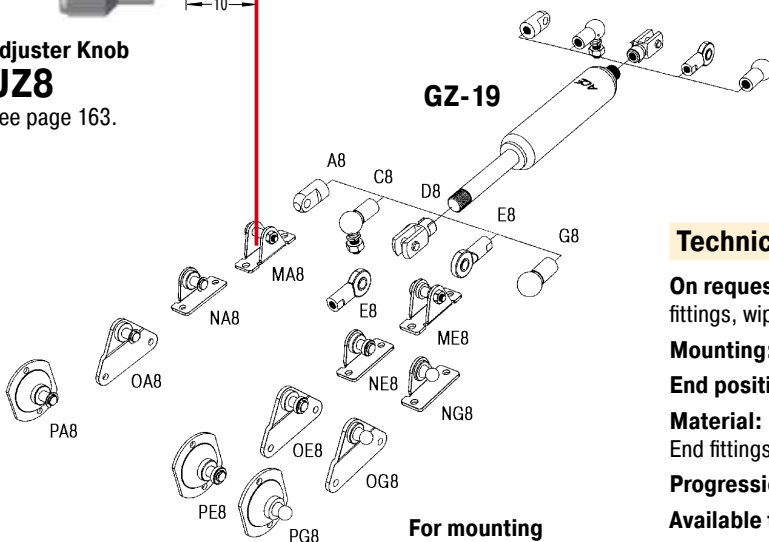

For mounting accessories see page 200.

Technical Data

On request: Special force curves, special lengths, alternative end fittings, wiper, stainless steel.

Mounting: In any position. Install mechanical stop in extended position.

End position damping length: Without damping.

Material: Piston rod: Hard chrome plated. Body: black coated. End fittings: Zinc plated steel.

Progression: Approx. 10 %, F₂ max. 330 N

Available traction force range F₁ at 20 °C: 30 N to 300 N

Note: Lifetime approx. 2000 m

Traction (Pull) Forces 150 N to 1200 N
(when Piston Rod Extended up to 1440 N)

End Fitting

Standard Dimensions

End Fitting

A10 Eye A10 max. force 10 000 N

B10 Stud Thread B10

C10 Angle Ball Joint C10 max. force 1800 N

D10 Clevis Fork D10 max. force 10 000 N

E10 Swivel Eye E10 max. force 10 000 N

Dimensions: $\varnothing 8.1$, $\varnothing 18$, 12 thick, Radius R9, 17, $\varnothing 10$, Stroke, $\varnothing 28$, L +/- 2 mm retracted, 25.

Dimensions		
Type	Stroke mm	L retracted
GZ-28-30	30	130
GZ-28-50	50	150
GZ-28-100	100	200
GZ-28-150	150	250
GZ-28-200	200	300
GZ-28-250	250	350
GZ-28-300	300	400
GZ-28-350	350	450
GZ-28-400	400	500
GZ-28-450	450	550
GZ-28-500	500	600
GZ-28-550	550	650
GZ-28-600	600	700
GZ-28-650	650	750

Ordering Example
GZ-28-150-EE-800
 Type (Pull Type) _____
 Body \varnothing (28 mm) _____
 Stroke (150 mm) _____
 Piston Rod End Fitting E10 _____
 Body End Fitting E10 _____
 Traction Force F_1 800 N _____

The end fittings are interchangeable and must be positively secured by the customer to prevent unscrewing (i.e. Loctite). For mounting accessories see page 200.

Rod Shroud W10-28

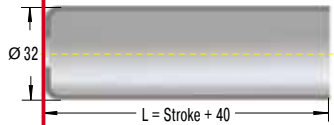

Adjuster Knob UZ10

See page 163.

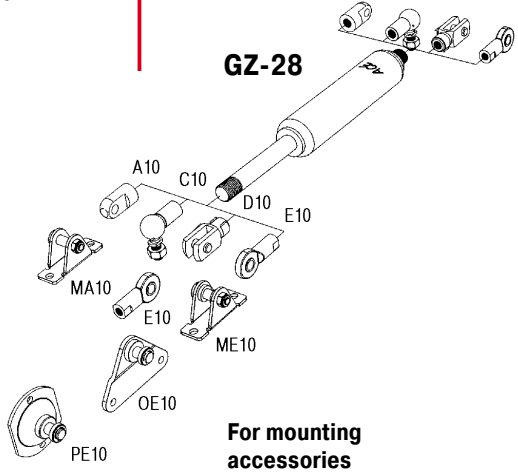

For mounting accessories see page 200.

Technical Data

- On request:** Special force curves, special lengths, alternative end fittings, wiper, stainless steel.
- Mounting:** In any position. Install mechanical stop in extended position.
- End position damping length:** Without damping.
- Material:** Piston rod: Hard chrome plated. Body: black coated. End fittings: Zinc plated steel.
- Progression:** Approx. 20%, F_2 max. 1440 N
- Available traction force range F_1 at 20 °C:** 150 N to 1200 N
- Note:** Lifetime approx. 2000 m

Issue 6.2011 Specifications subject to change

Traction (Pull) Forces 400 N to 5000 N
(when Piston Rod Extended up to 7000 N)

NEW

End Fitting

Standard Dimensions

End Fitting

A14

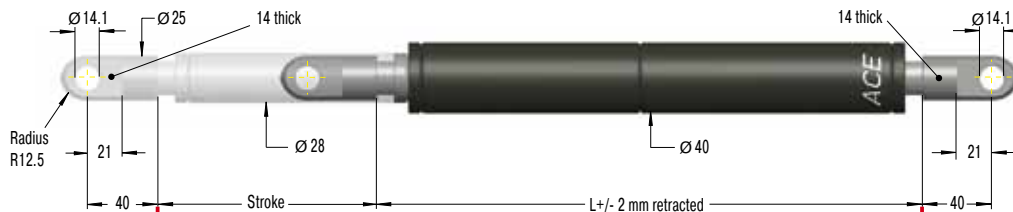

Eye A14

max. force 10 000 N

B14

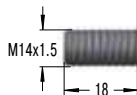

Stud Thread B14

C14

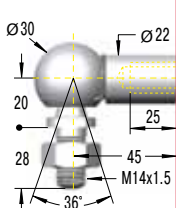

Angle Ball Joint C14

max. force 3200 N

D14

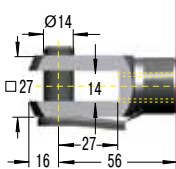

Clevis Fork D14

max. force 10 000 N

E14

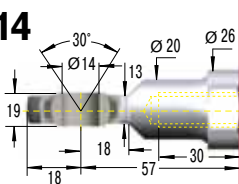

Swivel Eye E14

max. force 10 000 N

Dimensions

Type	Stroke mm	L retracted
GZ-40-100	100	250
GZ-40-150	150	325
GZ-40-200	200	400
GZ-40-250	250	475
GZ-40-300	300	550
GZ-40-400	400	700
GZ-40-500	500	850
GZ-40-600	600	1 000

Ordering Example

GZ-40-150-EE-800

Type (Pull Type) _____
 Body Ø (40 mm) _____
 Stroke (150 mm) _____
 Piston Rod End Fitting E14 _____
 Body End Fitting E14 _____
 Traction Force F_1 800 N _____

The end fittings are interchangeable and must be positively secured by the customer to prevent unscrewing (i.e. Loctite).
 For mounting accessories see page 201.

Rod Shroud W14-40

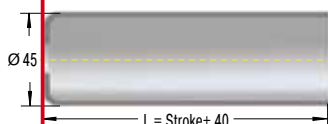

Adjuster Knob UZ14

See page 163.

GZ-40

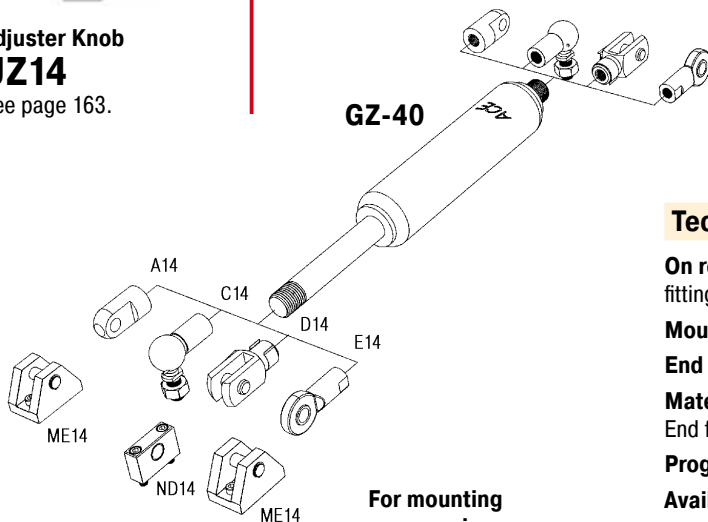

For mounting accessories see page 201.

Technical Data

On request: Special force curves, special lengths, alternative end fittings, wiper, stainless steel.

Mounting: In any position. Install mechanical stop in extended position.

End position damping length: Without damping

Material: Piston rod: Hard chrome plated. Body: black coated. End fittings: Zinc plated steel.

Progression: approx. 40%, F_2 max. 7000 N

Available traction force range F_1 at 20 °C: 400 N to 5000 N

Note: Lifetime approx. 2000 m

Stainless steel industrial traction gas springs

Material 1.4301/1.4305, AISI 304/303 (V2A)
 Material 1.4404/1.4571, AISI 316L/316Ti (V4A)

In addition to the comprehensive range of industrial gas springs with valve, ACE also offers a wide range of industrial traction gas springs made of stainless steel with body diameters from 15 mm to 40 mm. This high-quality version is also available on request in all stroke lengths and possible extension forces. The comprehensive range of fitting parts ensures easy installation and makes the gas traction springs universal in use. Stainless steel traction gas springs are used everywhere that raising and lowering is required. Due to their special properties, **non-rusting and low magnetism**, they are the preferred equipment for medical and clean-room technology, the foodstuffs industry, electronics and shipbuilding sector.

NEW

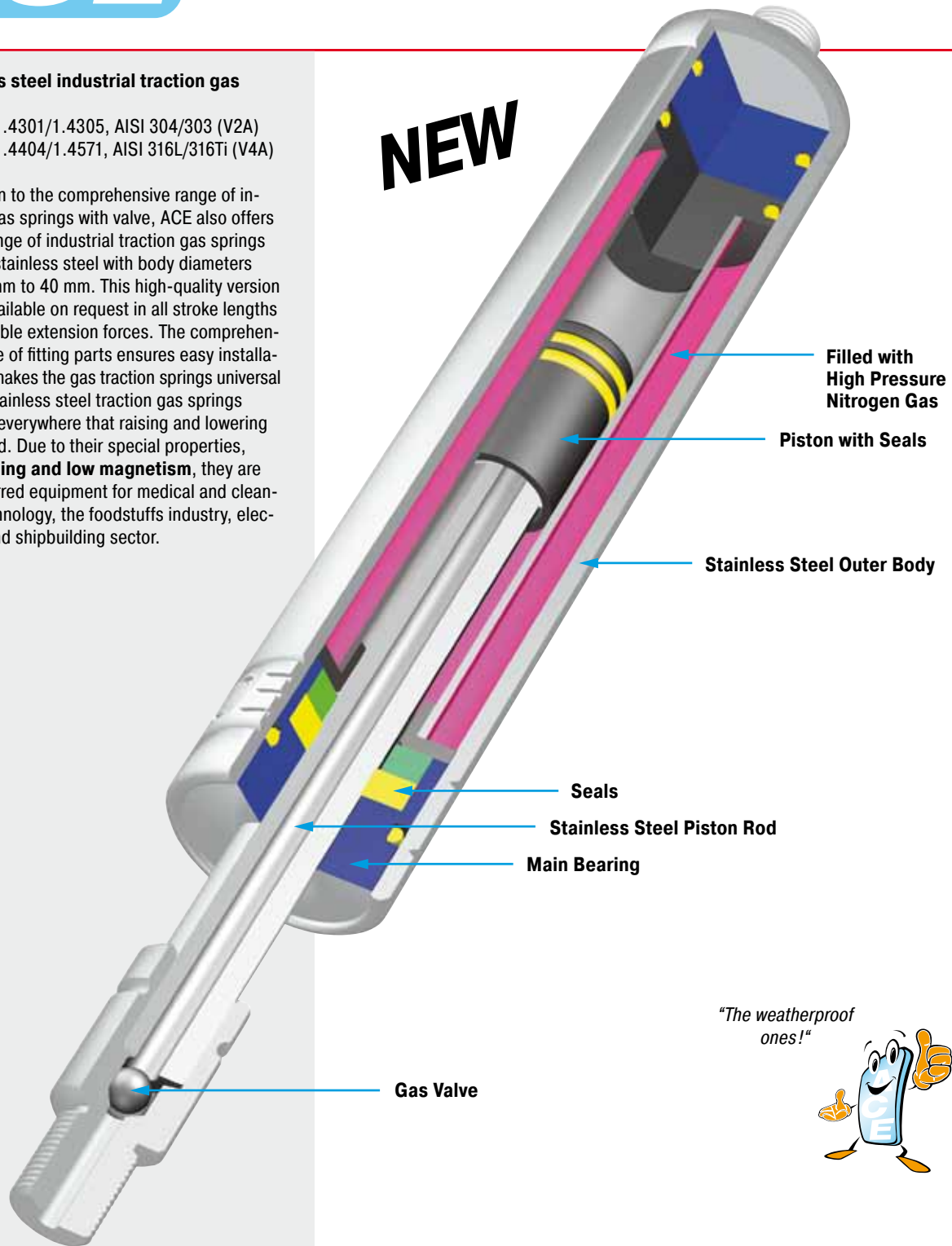

"The weatherproof ones!"



Issue 6.2011 Specifications subject to change

Operating fluid: Nitrogen gas

Material: Piston rod, body and end fittings: Material 1.4301/1.4305, AISI 304/303 (V2A) and material 1.4404/1.4571, AISI 316L/316Ti (V4A).

Mounting: In any position

Operating temperature range:
 -20 °C to 80 °C

On request: Special force curves, special lengths, alternative seals, wiper.



Traction (Pull) Forces 50 N to 300 N
(when Piston Rod Extended up to 370 N)

NEW

End Fitting

Standard Dimensions

End Fitting

B3,5



Stud Thread **B3,5**

A3,5-V4A

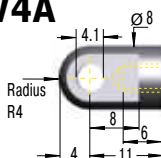

Eye
A3,5-V4A
max. force 370 N

C3,5-V4A

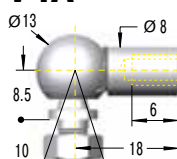

Angle Ball Joint
C3,5-V4A
max. force 370 N

D3,5-V4A

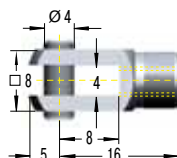

Clevis Fork
D3,5-V4A
max. force 370 N

G3,5-V4A

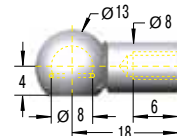

Ball Socket
G3,5-V4A
max. force 370 N

Dimensions

Type	Stroke mm	L retracted
GZ-15-20-V4A	20	87
GZ-15-40-V4A	40	107
GZ-15-50-V4A	50	117
GZ-15-60-V4A	60	127
GZ-15-80-V4A	80	147
GZ-15-100-V4A	100	167
GZ-15-120-V4A	120	187
GZ-15-150-V4A	150	217

Ordering Example

GZ-15-150-AC-150-V4A

Type (Pull Type) _____
 Body Ø (15 mm) _____
 Stroke (150 mm) _____
 Piston Rod End Fitting A3,5-V4A _____
 Body End Fitting C3,5-V4A _____
 Traction Force F₁ 150 N _____
 Indicated by K.-No. on delivery _____

The end fittings are interchangeable.
For mounting accessories see page 202.

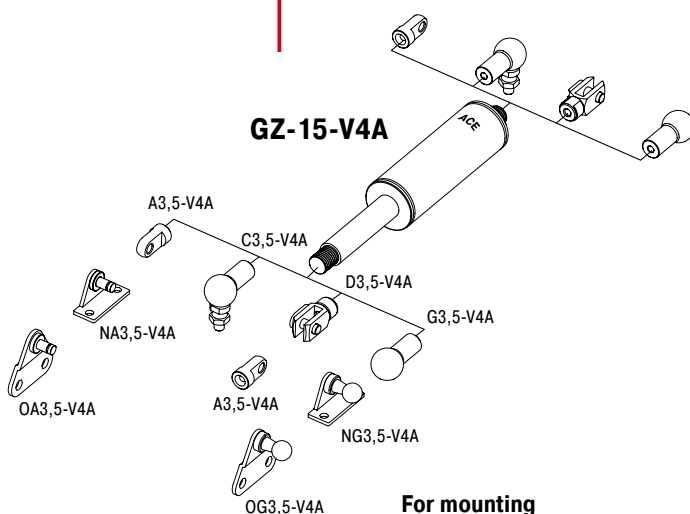

For mounting
accessories
see page 202.

Technical Data

On request: Special force curves, special lengths, alternative end fittings, rod shroud.

Mounting: In any position. Install mechanical stop in extended position.

End position damping length: Without damping

Material: Piston rod, body and end fittings: Material 1.4571/1.4404, AISI 316L/316Ti (V4A).

Progression: approx. 23 %, F₂ max. 370 N

Available traction force range F₁ at 20 °C: 50 N to 300 N

Note: Lifetime approx. 2000 m

Adjuster Knob **U3,5**
See page 163.

Traction (Pull) Forces 30 N to 300 N
(when Piston Rod Extended up to 333 N)

NEW

End Fitting

Standard Dimensions

End Fitting

B8

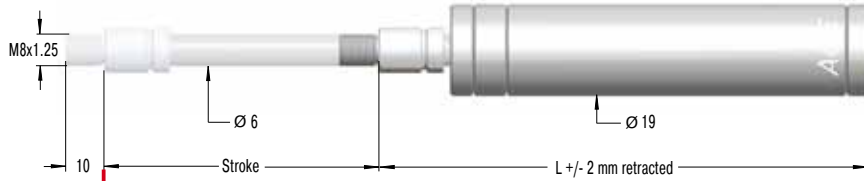

Stud Thread **B8**

A8-VA

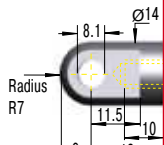

Eye
A8-VA
max. force 1560 N

C8-VA

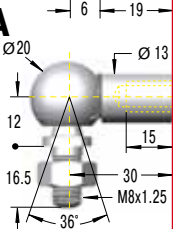

Angle Ball Joint
C8-VA
max. force 1140 N

D8-VA

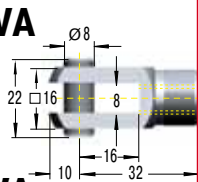

Clevis Fork
D8-VA
max. force 1560 N

E8-VA

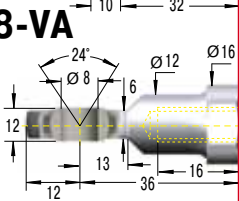

Swivel Eye
E8-VA
max. force 1560 N

G8-VA

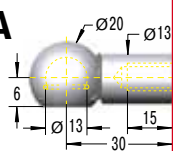

Ball Socket
G8-VA
max. force 1140 N

Rod Shroud
W8-19-VA

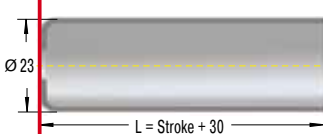

Dimensions

Type	Stroke mm	L retracted
GZ-19-30-VA	30	130
GZ-19-50-VA	50	150
GZ-19-100-VA	100	200
GZ-19-150-VA	150	250
GZ-19-200-VA	200	300
GZ-19-250-VA	250	350

Ordering Example

GZ-19-150-AC-150-VA

Type (Pull Type) _____
 Body Ø (19 mm) _____
 Stroke (150 mm) _____
 Piston Rod End Fitting A8-VA _____
 Body End Fitting C8-VA _____
 Traction Force F_1 150 N _____
 Indicated by K.-No. on delivery _____

The end fittings are interchangeable.
For mounting accessories see page 203.

Adjuster Knob
UZ8

See page 163.

GZ-19-VA

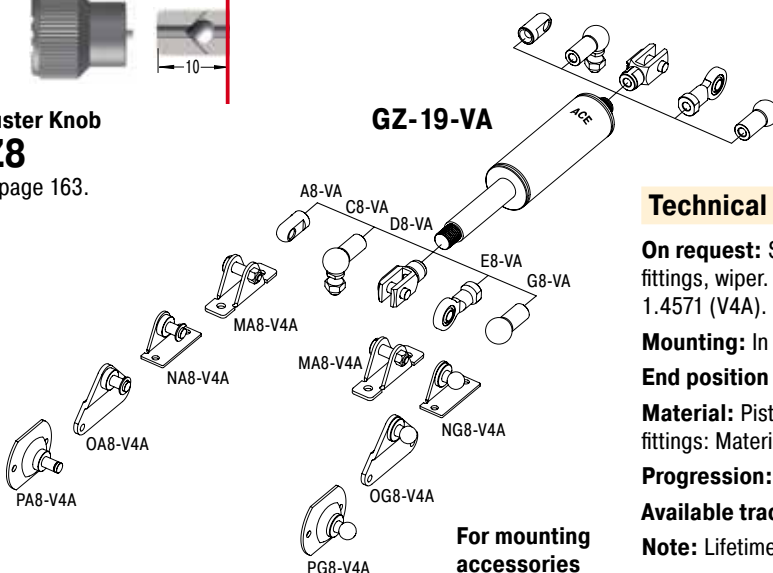

For mounting
accessories
see page 203.

Technical Data

On request: Special force curves, special lengths, alternative end fittings, wiper. Gas springs and accessories with material 1.4404/1.4571 (V4A).

Mounting: In any position. Install mechanical stop in extended position.

End position damping length: Without damping

Material: Piston rod: Material 1.4401, AISI 316L (V4A). Body and end fittings: Material 1.4301, AISI 304 (V2A).

Progression: Approx. 11%, F_2 max. 333 N

Available traction force range F_1 at 20 °C: 30 N to 300 N

Note: Lifetime approx. 2000 m

Traction (Pull) Forces 150 N to 1200 N
(when Piston Rod Extended up to 1460 N)

NEW

End Fitting

Standard Dimensions

End Fitting

B10

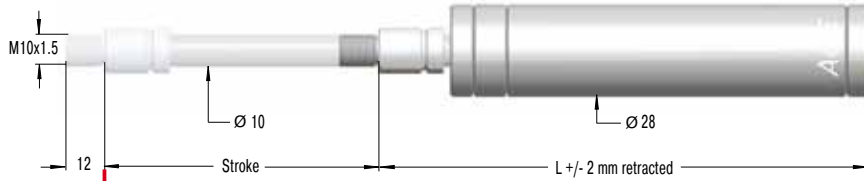

Stud Thread **B10**

A10-VA

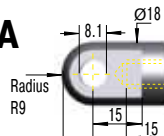

Eye A10-VA
max. force 3800 N

C10-VA

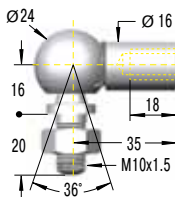

Angle Ball Joint C10-VA
max. force 1750 N

D10-VA

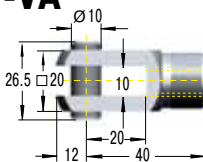

Clevis Fork D10-VA
max. force 3800 N

E10-VA

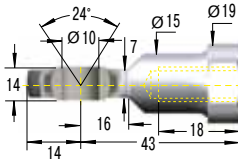

Swivel Eye E10-VA
max. force 3800 N

Dimensions

Type	Stroke mm	L retracted
GZ-28-50-VA	50	165
GZ-28-100-VA	100	215
GZ-28-150-VA	150	265
GZ-28-200-VA	200	315
GZ-28-250-VA	250	365
GZ-28-300-VA	300	415
GZ-28-350-VA	350	465
GZ-28-400-VA	400	515
GZ-28-450-VA	450	565
GZ-28-500-VA	500	615
GZ-28-550-VA	550	665
GZ-28-600-VA	600	715

Ordering Example

GZ-28-150-EE-800-VA

Type (Pull Type) _____
 Body Ø (28 mm) _____
 Stroke (150 mm) _____
 Piston Rod End Fitting E10-VA _____
 Body End Fitting E10-VA _____
 Traction Force F₁ 800 N _____
 Indicated by K.-No. on delivery _____

The end fittings are interchangeable.
For mounting accessories see page 203.

Rod Shroud

W10-28-VA

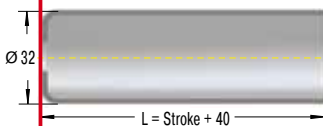

Adjuster Knob

UZ10

See page 163.

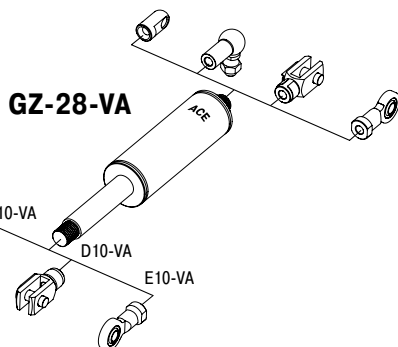

For mounting accessories see page 203.

Technical Data

On request: Special force curves, special lengths, alternative end fittings, wiper. Gas springs and accessories with material 1.4404/1.4571 (V4A).

Mounting: In any position. Install mechanical stop in extended position.

End position damping length: Without damping

Material: Piston rod, body and end fittings: Material 1.4301/1.4305, AISI 304/303 (V2A).

Progression: Approx. 22%, F₂ max. 1460 N

Available traction force range F₁ at 20 °C: 150 N to 1200 N

Note: Lifetime approx. 2000 m

Traction (Pull) Forces 400 N to 5000 N
(when Piston Rod Extended up to 7000 N)

NEW

End Fitting

Standard Dimensions

End Fitting

B14



Stud Thread **B14**

A14-VA

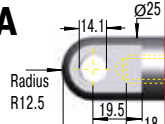

Dimensions

Type	Stroke mm	L retracted
GZ-40-100-VA	100	250
GZ-40-150-VA	150	325
GZ-40-200-VA	200	400
GZ-40-250-VA	250	475
GZ-40-300-VA	300	550
GZ-40-400-VA	400	700
GZ-40-500-VA	500	850
GZ-40-600-VA	600	1 000

Eye
A14-VA
max. force 7000 N

C14-VA

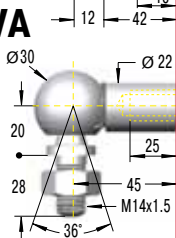

Angle Ball Joint
C14-VA
max. force 3200 N

D14-VA

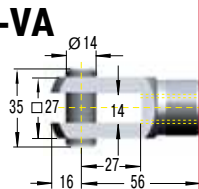

Clevis Fork
D14-VA
max. force 7000 N

E14-VA

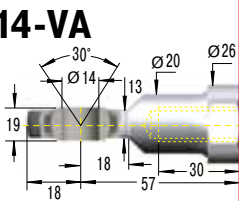

Swivel Eye
E14-VA
max. force 7000 N

Ordering Example

GZ-40-150-EE-800-VA

Type (Pull Type) _____
 Body Ø (40 mm) _____
 Stroke (150 mm) _____
 Piston Rod End Fitting E14-VA _____
 Body End Fitting E14-VA _____
 Traction Force F₁ 800 N _____
 Indicated by K.-No. on delivery _____

The end fittings are interchangeable.
For mounting accessories see page 204.

Rod Shroud
W14-40-VA

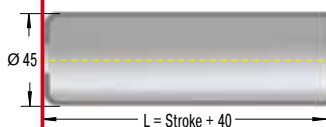

Adjuster Knob
UZ14

See page 163.

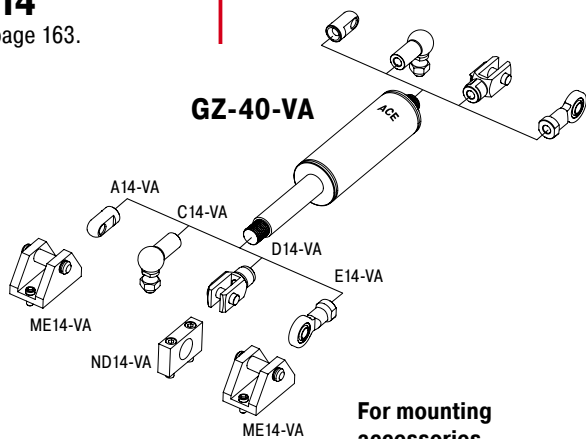

For mounting
accessories
see page 204.

Technical Data

On request: Special force curves, special lengths, alternative end fittings, wiper. Gas springs and accessories with material 1.4404/1.4571 (V4A).

Mounting: In any position. Install mechanical stop in extended position.

End position damping length: Without damping

Material: Piston rod, body and end fittings: Material 1.4301/1.4305, AISI 304/303 (V2A).

Progression: Approx. 40%, F₂ max. 7000 N

Available traction force range F₁ at 20 °C: 400 N to 5000 N

Note: Lifetime approx. 2000 m

By taking advantage of the very extensive range of **ACE end fittings and mounting brackets** you can easily and simply install our gas springs and hydraulic dampers. You profit from the variety of **DIN Standard** end fittings such as swivel eyes, clevis forks, angle ball joints, inline ball joints, and complementary ball sockets. ACE also offers eye fittings made of wear-resistant steel to meet the higher specification requirements found in industrial applications. With over 30 different types available these mounting accessories provide an extensive range of combinations for optimum installations. With the ACE selection programme you can choose not only your ACE gas springs but also the ideal end fittings and mounting brackets for your individual application example.

The complete range of accessories are also available as individual components.

"Just drill 4 holes – ACE does all the rest!"



Interchangeable Combinable

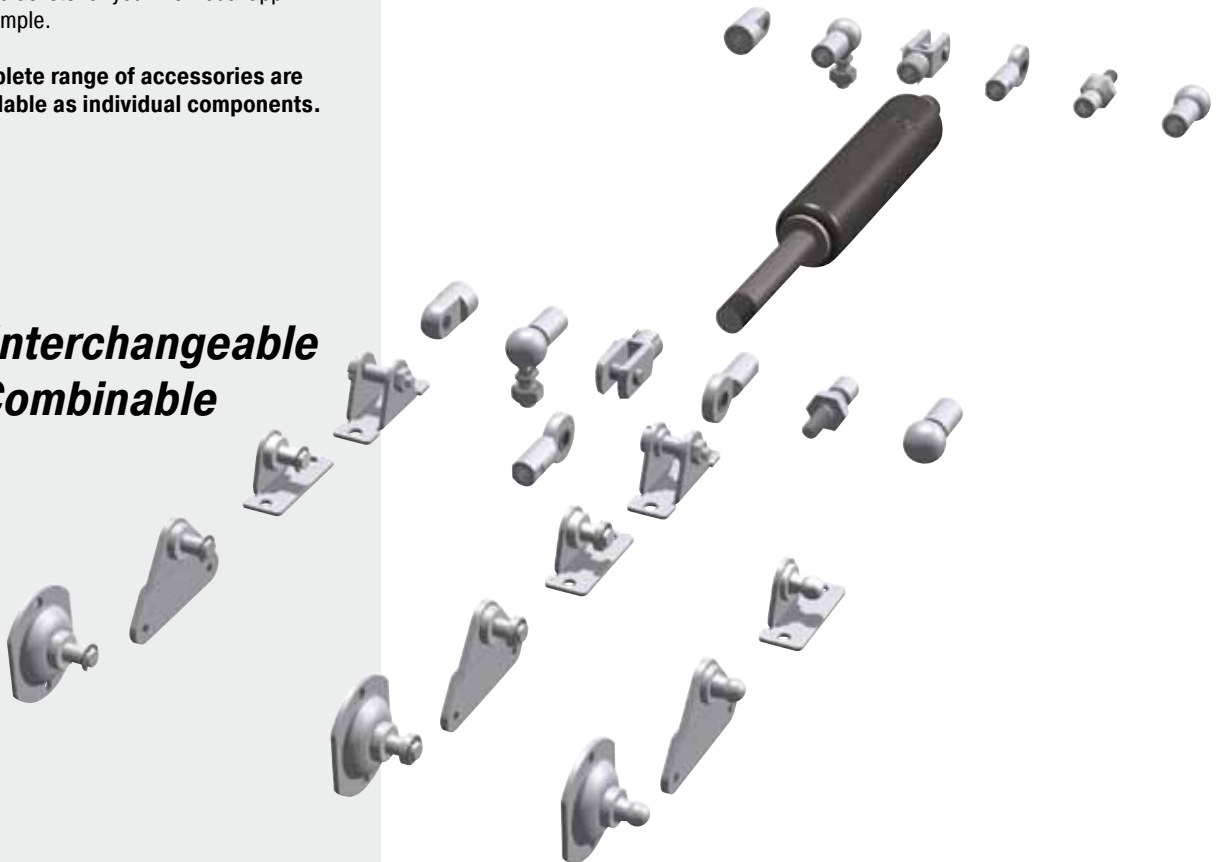

The wide range of mounting brackets available

Accessories M3.5x0.6

GS-8, GS-10, GS-12, GZ-15, HB-12

A3,5 Eye 1 max. force 370 N	C3,5 Angle Ball Joint DIN 71802 1 max. force 370 N	D3,5 Clevis Fork DIN 71752 1 max. force 370 N	E3,5 Swivel Eye DIN 648 1 max. force 370 N	G3,5 Ball Socket DIN 71805 1 max. force 370 N
1 max. force 180 N 	NA3,5 	NG3,5 	1 max. force 180 N 	OA3,5 OG3,5

Accessories M5x0.8

GS-15, HB-15

A5 Eye 1 max. force 800 N	C5 Angle Ball Joint DIN 71802 1 max. force 500 N	D5 Clevis Fork DIN 71752 1 max. force 800 N	E5 Swivel Eye DIN 648 1 max. force 800 N	F5 Inline Ball Joint Attention! Must only be used with compression loads. 1 max. force 500 N
G5 Ball Socket DIN 71805 1 max. force 500 N	1 max. force 500 N 	MA5 	1 max. force 400 N 	NA5 NG5
1 max. force 180 N 	OA5 	OG5 	1 max. force 500 N 	PA5 PG5

¹ Attention! Max. static load in Newtons. Beware force increase during compression (progression) and observe max. force limit.

Accessories M8x1.25

GS-19, GS-22, GZ-19, HB-22, HB-28, HBS-28, DVC-32

A8 Eye 1 max. force 3000 N	C8 Angle Ball Joint DIN 71802 1 max. force 1200 N	D8 Clevis Fork DIN 71752 1 max. force 3000 N	E8 Swivel Eye DIN 648 1 max. force 3000 N	F8 Inline Ball Joint Attention! Must only be used with compression loads. 1 max. force 1200 N	
G8 Ball Socket DIN 71805 1 max. force 1200 N	MA8 ME8 1 max. force 1800 N		1 max. force 1000 N NA8 NE8 NG8 1 max. force 1200 N		
1 max. force 1200 N 	OA8 	OE8 	1 max. force 1200 N 	PA8 PE8 PG8 	

Accessories M10x1.5

GS-28, GZ-28, HBS-35

A10 Eye 1 max. force 10 000 N	C10 Angle Ball Joint DIN 71802 1 max. force 1800 N	D10 Clevis Fork DIN 71752 1 max. force 10 000 N	E10 Swivel Eye DIN 648 1 max. force 10 000 N	F10 Inline Ball Joint Attention! Must only be used with compression loads. 1 max. force 1800 N	
1 max. force 1800 N 	MA10 ME10 		1 max. force 1200 N 		
1 max. force 1200 N 	OE10 	1 max. force 1200 N 	PE10 		

¹ Attention! Max. static load in Newtons. Beware force increase during compression (progression) and observe max. force limit.

Accessories M14x1.5

GS-40, GST-40, GZ-40, HB-40, HBD-70

<p>A14 Eye</p> <p>1 max. force 10 000 N</p>	<p>C14 Angle Ball Joint DIN 71802</p> <p>1 max. force 3200 N</p>	<p>D14 Clevis Fork DIN 71752</p> <p>1 max. force 10 000 N</p>	<p>E14 Swivel Eye DIN 648</p> <p>1 max. force 10 000 N</p>	<p>F14 Inline Ball Joint Attention! Must only be used with compression loads.</p> <p>1 max. force 3200 N</p>
<p>1 max. force 10 000 N</p> <p>ME14</p>		<p>1 max. force 10 000 N</p> <p>ND14</p>		

¹ Attention! Max. static load in Newtons. Beware force increase during compression (progression) and observe max. force limit.

Accessories M24x2

GS-70, HB-70, HBS-70

<p>D24 Clevis Fork DIN 71752</p> <p>1 max. force 50 000 N</p>	<p>E24 Swivel Eye DIN 648</p> <p>1 max. force 50 000 N</p>		
<p>1 max. force 50 000 N</p> <p>ME24</p>		<p>1 max. force 50 000 N</p> <p>ND24</p>	

¹ Attention! Max. static load in Newtons. Beware force increase during compression (progression) and observe max. force limit.

Accessories M3.5x0.6

GS-8-V4A, GS-10-V4A, GS-12-V4A, GZ-15-V4A

<p>A3,5-V4A Eye</p> <p>1 max. force 370 N</p>	<p>C3,5-V4A Angle Ball Joint</p> <p>1 max. force 370 N</p>	<p>D3,5-V4A Clevis Fork</p> <p>1 max. force 370 N</p>	<p>G3,5-V4A Ball Socket</p> <p>1 max. force 370 N</p>
<p>1 max. force 180 N</p>	<p>NA3,5-V4A NG3,5-V4A</p>	<p>1 max. force 180 N</p>	<p>OA3,5-V4A OG3,5-V4A</p>

Accessories M5x0.8

GS-15-VA

<p>A5-VA Eye</p> <p>1 max. force 490 N</p>	<p>C5-VA Angle Ball Joint</p> <p>1 max. force 430 N</p>	<p>D5-VA Clevis Fork</p> <p>1 max. force 490 N</p>	<p>E5-VA Swivel Eye</p> <p>1 max. force 490 N</p>	<p>G5-VA Ball Socket</p> <p>1 max. force 430 N</p>
<p>1 max. force 500 N</p>	<p>MA5-V4A</p>	<p>1 max. force 400 N</p>	<p>NA5-V4A NG5-V4A</p>	
<p>1 max. force 180 N</p>	<p>OA5-V4A OG5-V4A</p>	<p>1 max. force 500 N</p>	<p>PA5-V4A PG5-V4A</p>	

¹ Attention! Max. static load in Newtons. Beware force increase during compression (progression) and observe max. force limit.

Accessories M8x1.25 GS-19-VA, GS-22-VA, GZ-19-VA

<p>A8-VA Eye</p> <p>1 max. force 1560 N</p>	<p>C8-VA Angle Ball Joint</p> <p>1 max. force 1140 N</p>	<p>D8-VA Clevis Fork</p> <p>1 max. force 1560 N</p>	<p>E8-VA Swivel Eye</p> <p>1 max. force 1560 N</p>	<p>G8-VA Ball Socket</p> <p>1 max. force 1140 N</p>	
<p>1 max. force 1800 N</p>	<p>MA8-V4A</p>		<p>1 max. force 1000 N</p>	<p>NA8-V4A</p>	<p>NG8-V4A</p>
<p>1 max. force 1200 N</p>	<p>OA8-V4A</p>	<p>OG8-V4A</p>	<p>1 max. force 1200 N</p>	<p>PA8-V4A</p>	<p>PG8-V4A</p>

Accessories M10x1.5 GS-28-VA, GZ-28-VA

<p>A10-VA Eye</p> <p>1 max. force 3800 N</p>	<p>C10-VA Angle Ball Joint</p> <p>1 max. force 1750 N</p>	<p>D10-VA Clevis Fork</p> <p>1 max. force 3800 N</p>	<p>E10-VA Swivel Eye</p> <p>1 max. force 3800 N</p>
<p>1 max. force 1800 N</p>	<p>MA10-V4A</p>		

1 Attention! Max. static load in Newtons. Beware force increase during compression (progression) and observe max. force limit.

Accessories M14x1.5

GS-40-VA, GZ-40-VA

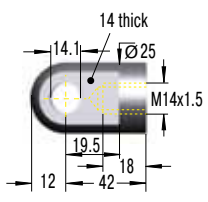
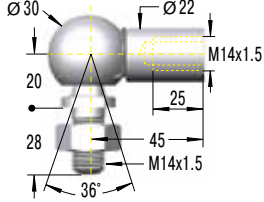
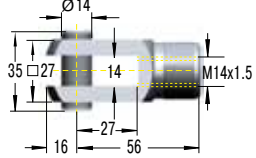
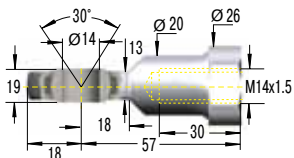
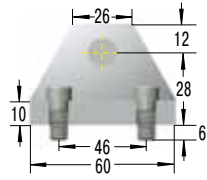
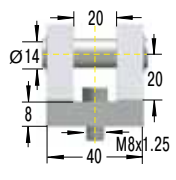
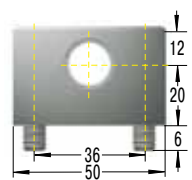
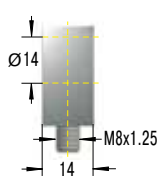
<p>A14-VA Eye</p>  <p>1 max. force 7000 N</p>	<p>C14-VA Angle Ball Joint</p>  <p>1 max. force 3200 N</p>	<p>D14-VA Clevis Fork</p>  <p>1 max. force 7000 N</p>	<p>E14-VA Swivel Eye</p>  <p>1 max. force 7000 N</p>
<p>1 max. force 10000 N</p> 	<p>ME14-VA</p> 	<p>1 max. force 10000 N</p> 	<p>ND14-VA</p> 

¹ Attention! Max. static load in Newtons. Beware force increase during compression (progression) and observe max. force limit.

Further Stainless Steel Gas Springs (Push Type), V4A

Type	Stroke mm	L extended	Dimensions see page
GS-15-20-V4A	20	74	182
GS-15-40-V4A	40	114	182
GS-15-50-V4A	50	134	182
GS-15-60-V4A	60	154	182
GS-15-80-V4A	80	194	182
GS-15-100-V4A	100	234	182
GS-15-120-V4A	120	274	182
GS-15-150-V4A	150	334	182
GS-19-50-V4A	50	164	183
GS-19-100-V4A	100	264	183
GS-19-150-V4A	150	364	183
GS-19-200-V4A	200	464	183
GS-19-250-V4A	250	564	183
GS-19-300-V4A	300	664	183
GS-22-50-V4A	50	164	184
GS-22-100-V4A	100	264	184
GS-22-150-V4A	150	364	184
GS-22-200-V4A	200	464	184
GS-22-250-V4A	250	564	184
GS-22-300-V4A	300	664	184
GS-22-350-V4A	350	764	184
GS-22-400-V4A	100	864	184
GS-22-450-V4A	450	964	184
GS-22-500-V4A	500	1 064	184
GS-22-550-V4A	550	1 164	184
GS-22-600-V4A	600	1 264	184
GS-22-650-V4A	650	1 364	184
GS-22-700-V4A	700	1 464	184
GS-28-100-V4A	100	262	185
GS-28-150-V4A	150	362	185
GS-28-200-V4A	200	462	185
GS-28-250-V4A	250	562	185
GS-28-300-V4A	300	662	185
GS-28-350-V4A	350	762	185
GS-28-400-V4A	400	862	185
GS-28-450-V4A	450	962	185
GS-28-500-V4A	500	1 062	185
GS-28-550-V4A	550	1 162	185
GS-28-600-V4A	600	1 262	185
GS-28-650-V4A	650	1 362	185
GS-40-100-V4A	100	317	186
GS-40-150-V4A	150	417	186
GS-40-200-V4A	200	517	186
GS-40-300-V4A	300	717	186
GS-40-400-V4A	400	917	186
GS-40-500-V4A	500	1 117	186
GS-40-600-V4A	600	1 317	186

Further Stainless Steel Gas Springs (Pull Type), V4A

Type	Stroke mm	L retracted	Dimensions see page
GZ-19-30-V4A	30	130	195
GZ-19-50-V4A	50	150	195
GZ-19-100-V4A	100	200	195
GZ-19-150-V4A	150	250	195
GZ-19-200-V4A	200	300	195
GZ-19-250-V4A	250	350	195
GZ-28-50-V4A	50	165	196
GZ-28-100-V4A	100	215	196
GZ-28-150-V4A	150	265	196
GZ-28-200-V4A	200	315	196
GZ-28-250-V4A	250	365	196
GZ-28-300-V4A	300	415	196
GZ-28-350-V4A	350	465	196
GZ-28-400-V4A	400	515	196
GZ-28-450-V4A	450	565	196
GZ-28-500-V4A	500	615	196
GZ-28-550-V4A	550	665	196
GZ-28-600-V4A	600	715	196
GZ-40-100-V4A	100	250	197
GZ-40-150-V4A	150	325	197
GZ-40-200-V4A	200	400	197
GZ-40-250-V4A	250	475	197
GZ-40-300-V4A	300	550	197
GZ-40-400-V4A	400	700	197
GZ-40-500-V4A	500	850	197
GZ-40-600-V4A	600	1 000	197

*"Applicable
under extreme environment
conditions!"*



Further Stainless Steel End Fittings, V4A

End Fittings	Dimensions see page
A5-V4A	202
C5-V4A	202
D5-V4A	202
E5-V4A	202
G5-V4A	202
A8-V4A	203
C8-V4A	203
D8-V4A	203
E8-V4A	203
G8-V4A	203
A10-V4A	203
C10-V4A	203
D10-V4A	203
E10-V4A	203
A14-V4A	204
C14-V4A	204
D14-V4A	204
E14-V4A	204