

ACE miniature shock absorbers are maintenance-free, self-contained hydraulic components. The model range **MC5 to MC75** have a very short overall length and a low return force. The shock absorber is filled with a temperature stable oil and has an integrated positive stop. They are ideally suited for small, fast, handling equipment, rotary actuators, pick and place mechanisms and similar small automation equipment. A wide choice of metering hardnesses enable these units to cover applications with effective weights ranging from 0.3 kg to 36 kg.

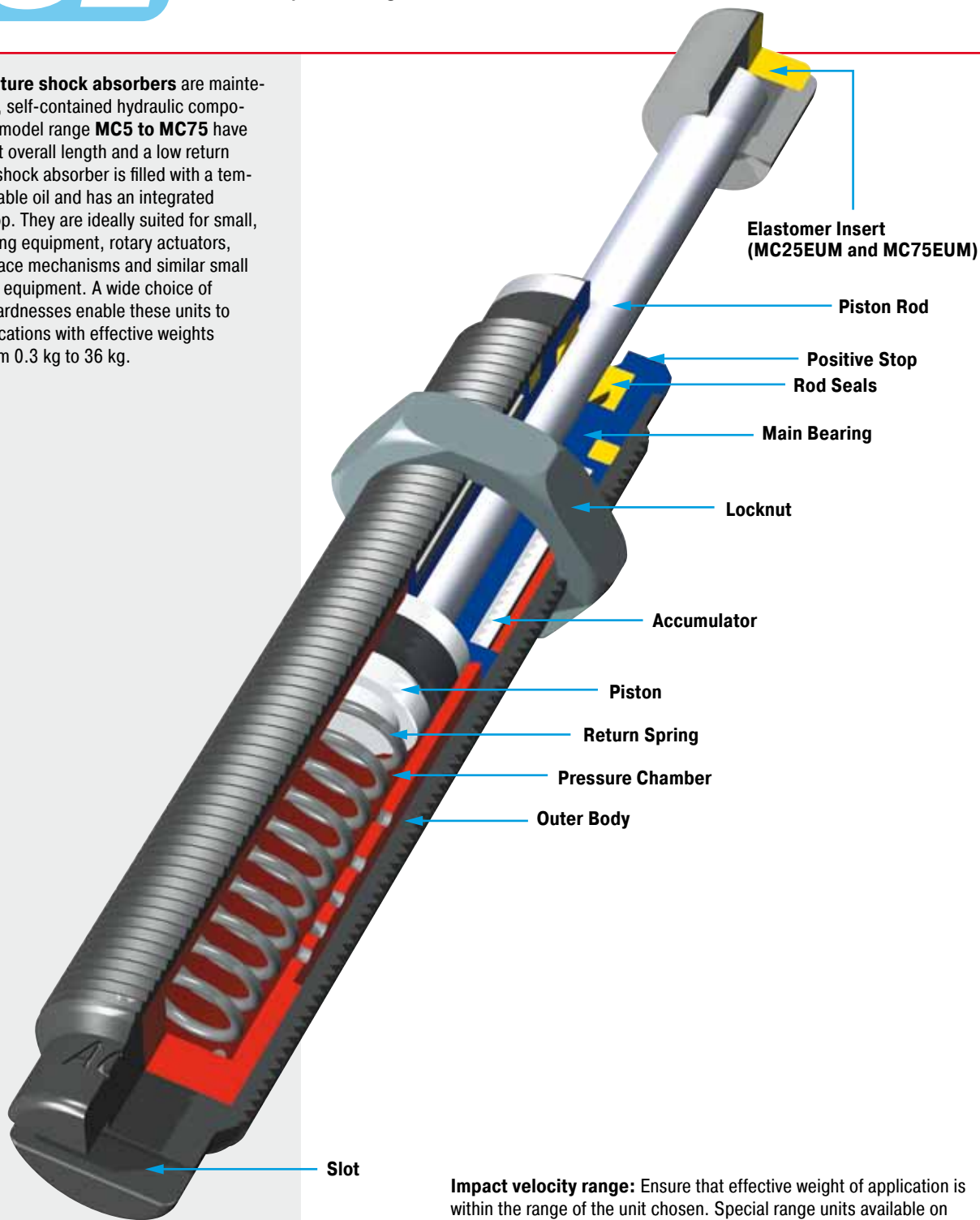

Impact velocity range: Ensure that effective weight of application is within the range of the unit chosen. Special range units available on request.

Material: Shock absorber body: Steel with black oxide finish or nitride hardened. Accessories: Steel with black oxide finish or nitride hardened. Piston rod: Hardened stainless steel. Locknut MC5 and MC9: Aluminium.

W₄ capacity rating: (max. energy per hour Nm/hr) If your application exceeds the tabulated W₄ figures consider additional cooling i.e. cylinder exhaust air etc. Ask ACE for further details.

Mounting: In any position. If precise end position datum is required consider use of the optional stop collar type AH.

Operating temperature range: 0 °C to 66 °C

On request: Weartec finish (seawater resistant). Other finishes available to special order.



MC5EUM

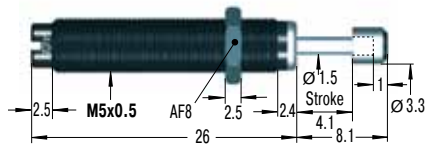

Accessories, mounting, installation ... see pages 36 to 41.

MC9EUM

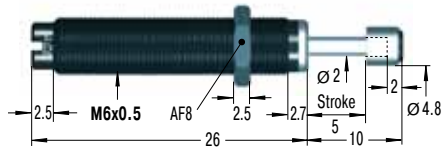

Accessories, mounting, installation ... see pages 36 to 41.

MC30EUM for use on new installations

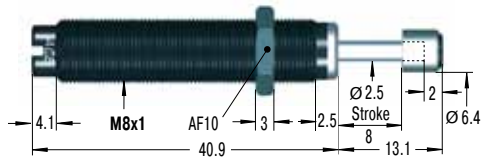

Accessories, mounting, installation ... see pages 36 to 41.

MC25EUM

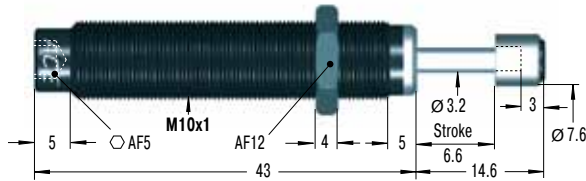

Accessories, mounting, installation ... see pages 36 to 41.

MC75EUM

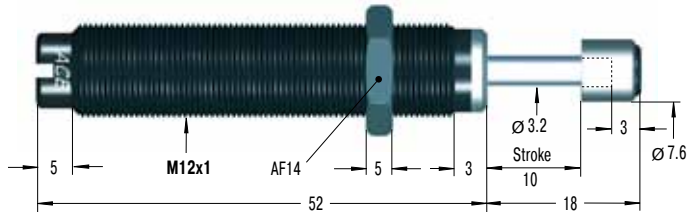

Accessories, mounting, installation ... see pages 37 to 41.

Available without rod end button on request.

Capacity Chart

Type Part Number	Max. Energy Capacity		Effective Weight me		Min. Return Force N	Max. Return Force N	Rod Reset Time s	1 Max. Side Load Angle °	Weight kg
	W ₃ Nm/Cycle	W ₄ Nm/h	me min. kg	me max. kg					
MC5EUM-1-B	0.68	2 040	0.5	4.4	1	5	0.2	2	0.003
MC5EUM-2-B	0.68	2 040	3.8	10.8	1	5	0.2	2	0.003
MC5EUM-3-B	0.68	2 040	9.7	18.7	1	5	0.2	2	0.003
MC9EUM-1-B	1	2 000	0.6	3.2	2	4	0.3	2	0.005
MC9EUM-2-B	1	2 000	0.8	4.1	2	4	0.3	2	0.005
MC10EUMML-B	1.25	4 000	0.3	2.7	2	4	0.6	3	0.010
MC10EUMMH-B	1.25	4 000	0.7	5	2	4	0.6	3	0.010
MC30EUM-1	3.5	5 600	0.4	1.9	2	6	0.3	2	0.010
MC30EUM-2	3.5	5 600	1.8	5.4	2	6	0.3	2	0.010
MC30EUM-3	3.5	5 600	5	15	2	6	0.3	2	0.010
MC25EUMML	2.8	22 600	0.7	2.2	3	6	0.3	2	0.020
MC25EUMH	2.8	22 600	1.8	5.4	3	6	0.3	2	0.020
MC25EUMMH	2.8	22 600	4.6	13.6	3	6	0.3	2	0.020
MC75EUM-1	9	28 200	0.3	1.1	4	9	0.3	2	0.030
MC75EUM-2	9	28 200	0.9	4.8	4	9	0.3	2	0.030
MC75EUM-3	9	28 200	2.7	36.2	4	9	0.3	2	0.030

1 For applications with higher side load angles consider using the side load adaptor (BV) pages 36 to 40.

MB5SC2



Mounting Block

RF6

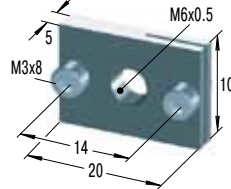

Rectangular Flange

MB6SC2

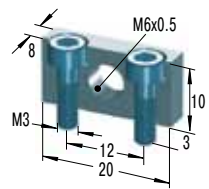

Mounting Block

MC10EUM still available in future

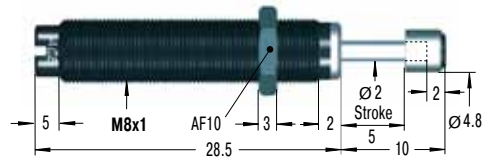

M8x0.75 also available to order

RF10

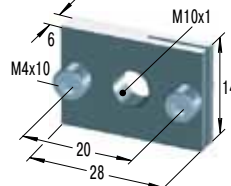

Rectangular Flange

MB10SC2

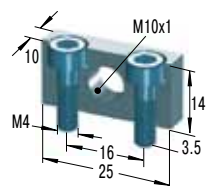

Mounting Block

RF12

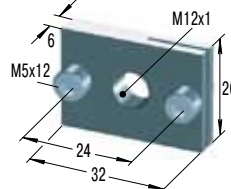

Rectangular Flange

MB12

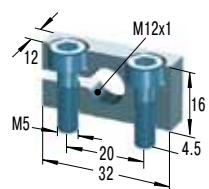

Clamp Mount

ACE miniature shock absorbers are maintenance-free, self-contained hydraulic components. The hermetically sealed rolling diaphragm seal system used on the **MC150 to MC600** model range provides the **highest possible cycle lifetime; up to 25 million cycles being achievable**. All models incorporate an integral positive stop. The rolling diaphragm seal provides an extremely low rod return force. These models can be directly mounted into the end cover of pneumatic cylinders (up to 7 bar) to provide superior end damping compared to normal cylinder cushions. By adding the optional side load adaptor it is possible to accept side loads up to 25° from the axis. The wide range of models available ensure a seamless range of operation on applications with effective weights ranging from 0.9 kg up to 4536 kg by selecting the appropriate model.

"Rolling diaphragm seal system – up to 25 million cycles possible!"

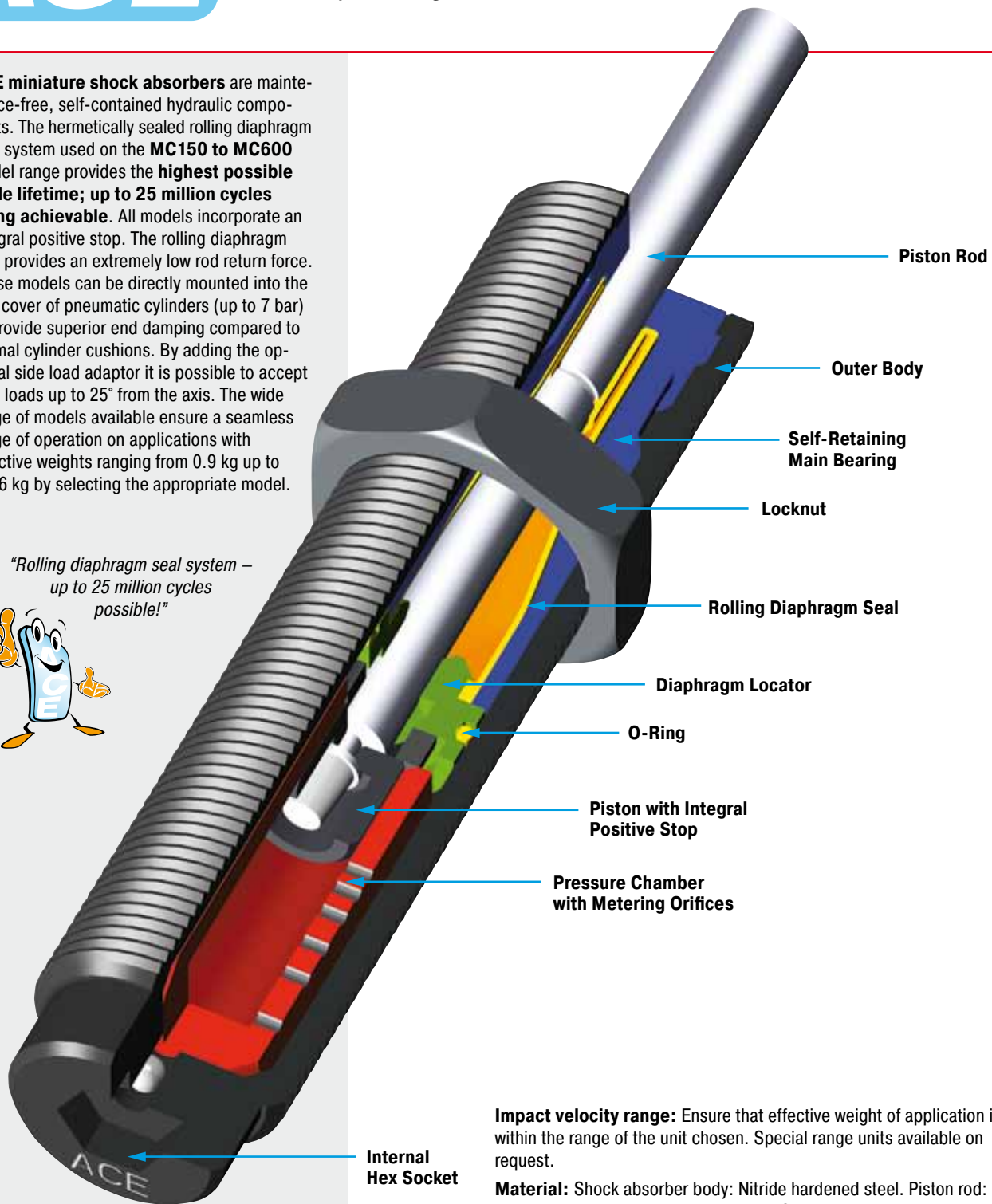

Impact velocity range: Ensure that effective weight of application is within the range of the unit chosen. Special range units available on request.

Material: Shock absorber body: Nitride hardened steel. Piston rod: Hardened stainless steel. Accessories: Steel with black oxide finish or nitride hardened. Rolling diaphragm seal: EPDM.

Note: Local contamination can effect the rolling seal and reduce the lifetime. Please contact ACE for a suitable solution.

W₄ capacity rating: (max. energy per hour Nm/hr) If your application exceeds the tabulated W₄ figures consider additional cooling i. e. cylinder exhaust air etc. Ask ACE for further details.

Mounting: In any position. If precise end position datum is required consider use of the optional stop collar type AH.

Operating temperature range: 0 °C to 66 °C

On request: Weartec finish (seawater resistant). Other finishes available to special order.



MC150EUM

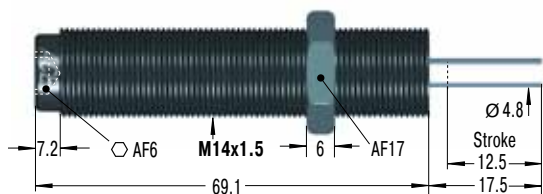

M14x1 also available to special order
Accessories, mounting, installation ... see pages 37 to 41.

PP150

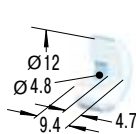

Nylon Button
W₃ max = 14 Nm

RF14

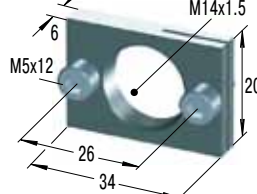

Rectangular Flange

MB14

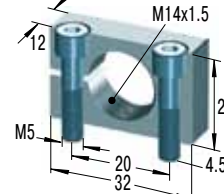

Clamp Mount

MC225EUM

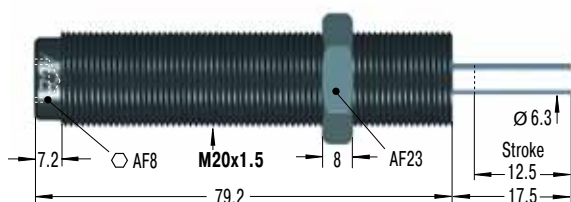

Accessories, mounting, installation ... see pages 38 to 41.

PP225

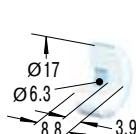

Nylon Button
W₃ max = 33 Nm

RF20

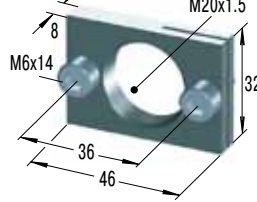

Rectangular Flange

MB20

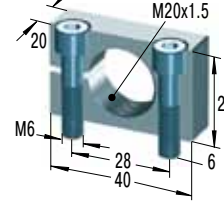

Clamp Mount

MC600EUM

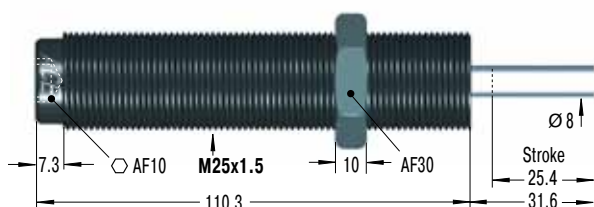

M27x3 also available to special order
Accessories, mounting, installation ... see pages 38 to 41.

PP600

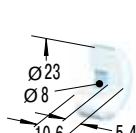

Nylon Button
W₃ max = 68 Nm

RF25

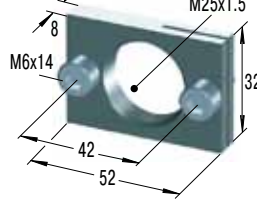

Rectangular Flange

MB25

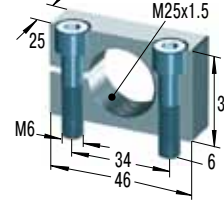

Clamp Mount

Capacity Chart

Type Part Number	Max. Energy Capacity		Effective Weight me Self-Compensating		Min. Return Force N	Max. Return Force N	Rod Reset Time s	1 Max. Side Load Angle °	Weight kg
	W ₃ Nm/Cycle	W ₄ Nm/h	me min. kg	me max. kg					
MC150EUM	20	34 000	0.9	10	3	8	0.4	4	0.06
MC150EUMH	20	34 000	8.6	86	3	8	0.4	4	0.06
MC150EUMH2	20	34 000	70	200	3	8	0.4	4	0.06
MC150EUMH3	20	34 000	181	408	3	8	1	4	0.06
MC225EUM	41	45 000	2.3	25	4	9	0.3	4	0.15
MC225EUMH	41	45 000	23	230	4	9	0.3	4	0.15
MC225EUMH2	41	45 000	180	910	4	9	0.3	4	0.15
MC225EUMH3	41	45 000	816	1 814	4	9	0.3	4	0.15
MC600EUM	136	68 000	9	136	5	10	0.6	2	0.26
MC600EUMH	136	68 000	113	1 130	5	10	0.6	2	0.26
MC600EUMH2	136	68 000	400	2 300	5	10	0.6	2	0.26
MC600EUMH3	136	68 000	2 177	4 536	5	10	0.6	2	0.26

¹ For applications with higher side load angles consider using the side load adaptor (BV) pages 37 to 40.

Based on the proven damping technology of the MC150 to 600 series, these self-adjusting ACE miniature shock absorbers are offered in stainless steel. The outer body, hardened piston rod and all accessories are made of V4A (material 1.4404). The **MC150 to MC600-V4A series** is therefore ideally suited for applications in medical technology, the food and packaging industry, electronics, dock side installations and marine industries. These special dampers offer all the advantages of the MC standard series. The ACE rolling seal membrane achieves the longest lifetime of any shock absorber and can withstand up to 7 bars when directly mounted into a pressure chamber. The wide range of models available ensure a seamless range of operation on applications with effective weights from 0.9 to 4536 kg. With an integrated positive stop and accessories also in V4A this range allows for many different application possibilities. By using the option to fill types MC150 to 600 with special oil that fulfils the requirements (NSF-H1) of the food industry there is a ready made shock absorber system ideally suited to the food processing and packaging industry.



"Also available with special oil suited for the food industry!"

NEW

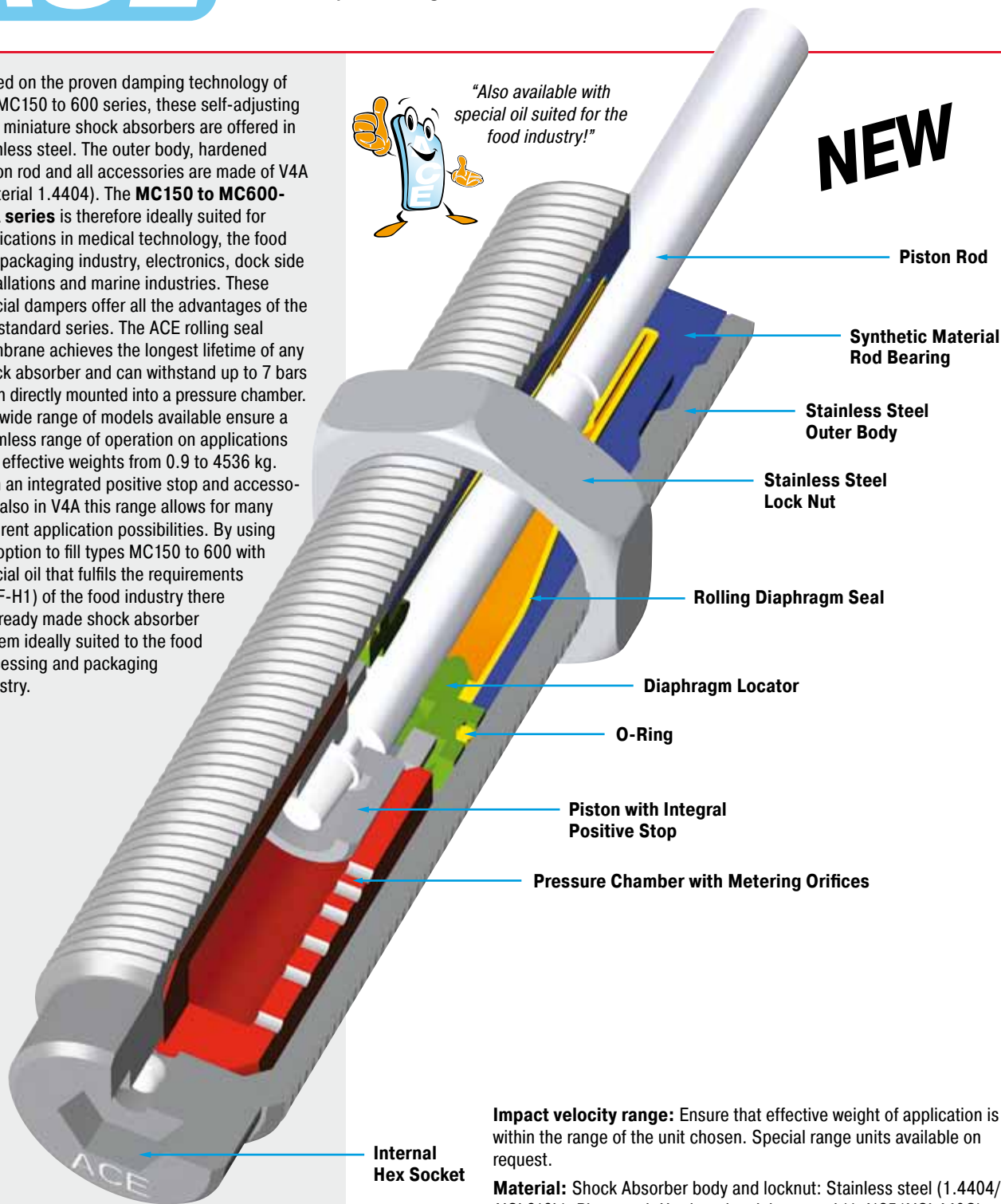

Impact velocity range: Ensure that effective weight of application is within the range of the unit chosen. Special range units available on request.

Material: Shock Absorber body and locknut: Stainless steel (1.4404/AISI 316L). Piston rod: Hardened stainless steel (1.4125/AISI 440C). Rolling diaphragm seal: EPDM. Accessories: Stainless steel (1.4404/AISI 316L).

Note: Local contamination can affect the rolling seal and reduce the lifetime. Please contact ACE for a suitable solution.

W₄ capacity rating: (max. energy per hour Nm/hr) If your application exceeds the tabulated W₄ figures consider additional cooling i. e. cylinder exhaust air etc. Ask ACE for further details.

Mounting: In any position. If precise end position datum is required consider use of the optional stop collar type AH.

Operating temperature range: 0 °C to 66 °C

On request: Special oils, seals and special accessories.



MC150EUM-V4A

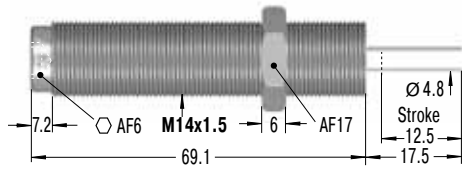

PP150

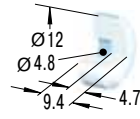

Nylon Button
W₃ max = 14 Nm

AH14-V4A

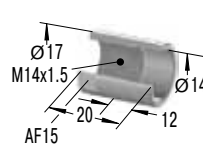

Stop Collar

MB14SC2-V4A

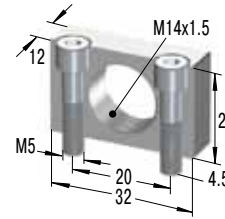

Mounting Block

KM14-V4A



Locknut

MC225EUM-V4A

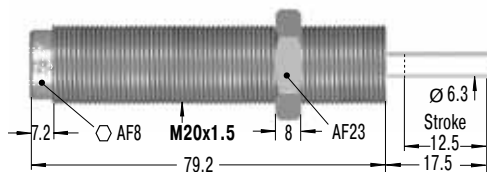

PP225

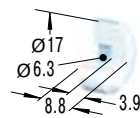

Nylon Button
W₃ max = 33 Nm

AH20-V4A

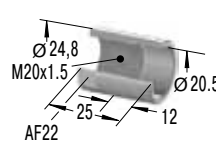

Stop Collar

MB20SC2-V4A

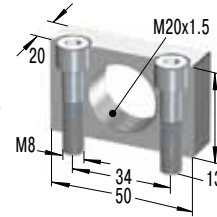

Mounting Block

KM20-V4A



Locknut

MC600EUM-V4A

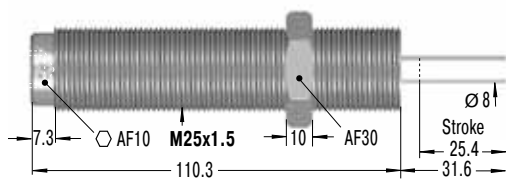

PP600

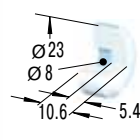

Nylon Button
W₃ max = 68 Nm

AH25-V4A

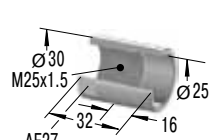

Stop Collar

MB25SC2-V4A

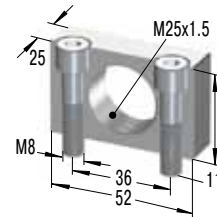

Mounting Block

KM25-V4A

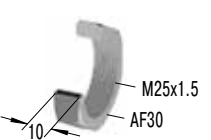

Locknut

Capacity Chart

Type Part Number	Max. Energy Capacity		Effective Weight me Self-Compensating		Min. Return Force N	Max. Return Force N	Rod Reset Time s	1 Max. Side Load Angle °	Weight kg
	W ₃ Nm/Cycle	W ₄ Nm/h	me min. kg	me max. kg					
MC150EUM-V4A	20	34 000	0.9	10	3	5	0.4	4	0.06
MC150EUMH-V4A	20	34 000	8.6	86	3	5	0.4	4	0.06
MC150EUMH2-V4A	20	34 000	70	200	3	5	0.4	4	0.06
MC150EUMH3-V4A	20	34 000	181	408	3	5	1	4	0.06
MC225EUM-V4A	41	45 000	2.3	25	4	6	0.3	4	0.15
MC225EUMH-V4A	41	45 000	23	230	4	6	0.3	4	0.15
MC225EUMH2-V4A	41	45 000	180	910	4	6	0.3	4	0.15
MC225EUMH3-V4A	41	45 000	816	1 814	4	6	0.3	4	0.15
MC600EUM-V4A	136	68 000	9	136	5	9	0.6	2	0.27
MC600EUMH-V4A	136	68 000	113	1 130	5	9	0.6	2	0.27
MC600EUMH2-V4A	136	68 000	400	2 300	5	9	0.6	2	0.27
MC600EUMH3-V4A	136	68 000	2 177	4 536	5	9	0.6	2	0.27

¹ For applications with higher side load angles please contact ACE.

These new ACE shock absorbers of the Protection series PMC were designed for applications with particular fluid requirements. The special protective cap made of PTFE (Teflon) hermetically seals the entire damping system (the proven rolling seal) against outside influences. Aggressive cutting, cooling, or cleaning agents are thus not able to contaminate the shocks inside the system. A stainless steel button integrated in the cap absorbs the impact energy reliably and establishes longest lifetimes for the shock absorber. The new Protection series offers the perfect alternative to the ACE air bleed collar of the SP series, when the machine or equipment does not possess its own compressed air. The Protection series is available for thread sizes **M14 to M25** and can find applications in all those environments where common shock absorbers cannot be used because of aggressive fluids. The Protection series is of special interest for the food industry as the shocks can be delivered with a V4A stainless (material number 1.4404) steel outer body.

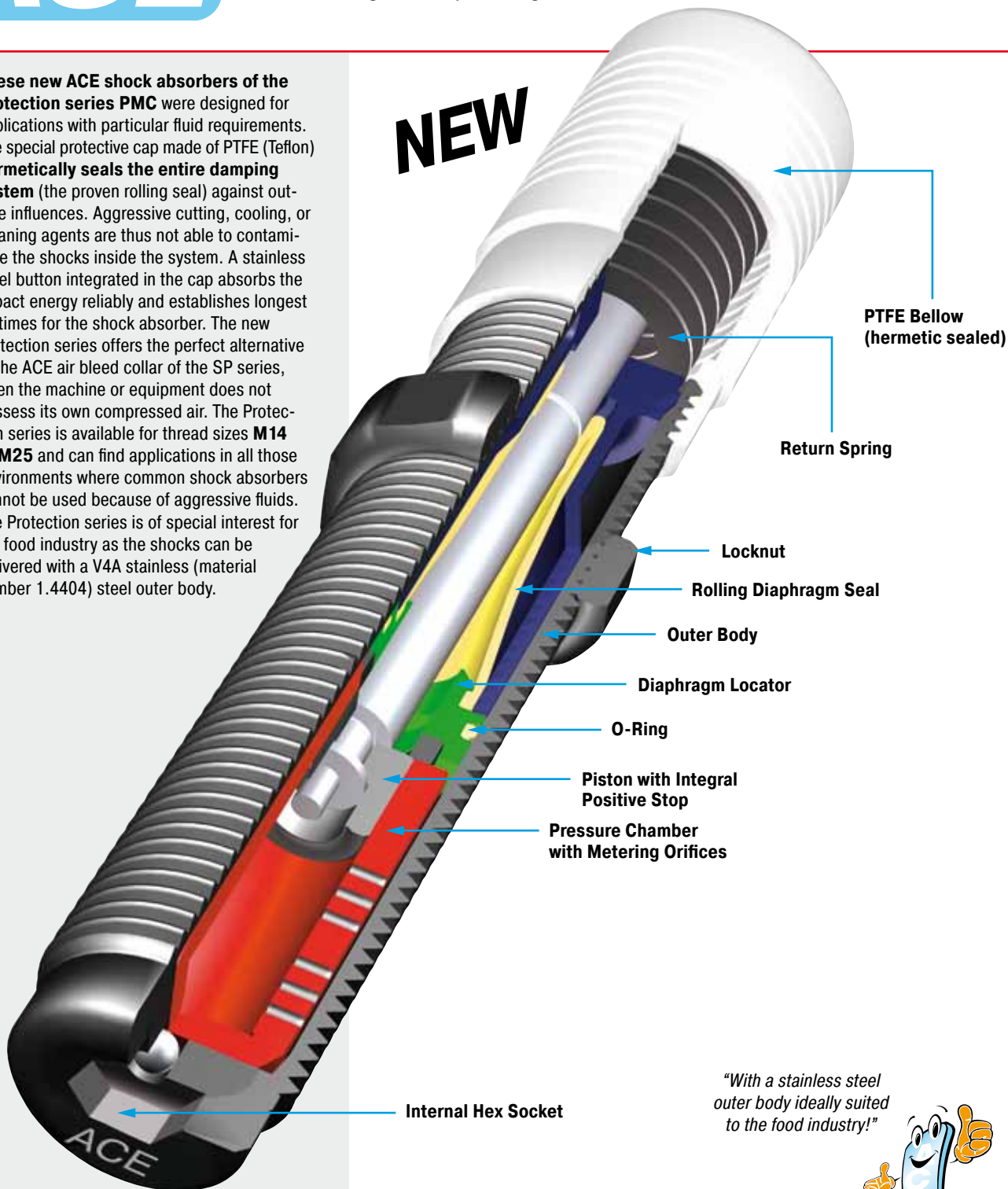

"With a stainless steel outer body ideally suited to the food industry!"



Impact velocity range: Ensure that effective weight of application is within the range of the unit chosen. Special range units available on request.

Material: Bellows: PTFE. Steel insert: Stainless Steel 1.4404/AISI 316L. Shock absorber body: Nitride hardened steel or stainless steel 1.4404/AISI 316L.

Note: Final preliminary test must be done on the application.

Mounting: In any position

Operating temperature range: 0 °C to 66 °C



PMC150EUM

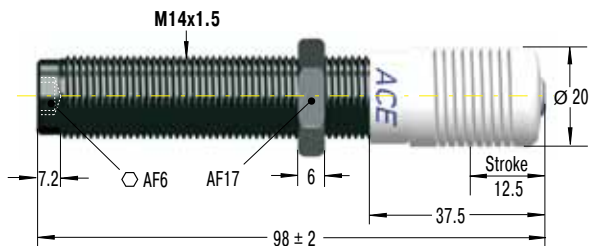

PMC150EUM-V4A



Dimensions as PMC150EUM

PMC225EUM

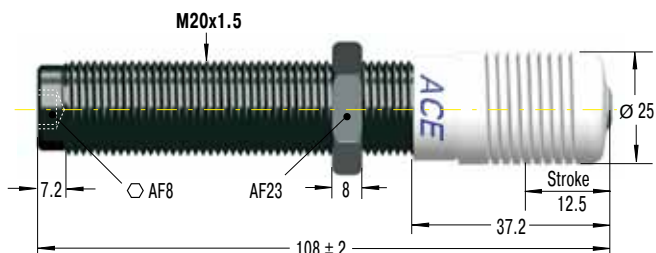

PMC225EUM-V4A



Dimensions as PMC225EUM

PMC600EUM

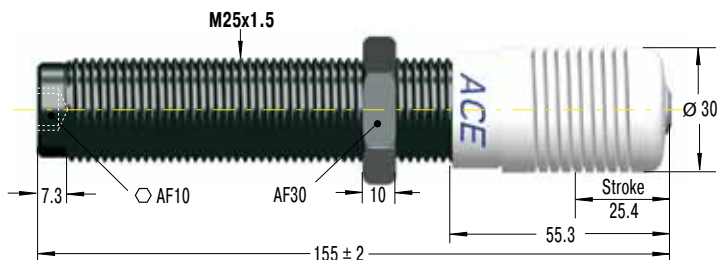

PMC600EUM-V4A



Dimensions as PMC600EUM

Capacity Chart

Type	Max. Energy Capacity		Effective Weight me Self-Compensating		Min. Return Force N	Max. Return Force N	Rod Reset Time s	Max. Side Load Angle °	Weight kg
	W ₃ Nm/Cycle	W ₄ Nm/h	me min. kg	me max. kg					
PMC150EUM	20	34 000	0.9	10	5	60	0.4	4	0.08
PMC150EUMH	20	34 000	8.6	86	5	60	0.4	4	0.08
PMC150EUMH2	20	34 000	70	200	5	60	0.4	4	0.08
PMC150EUMH3	20	34 000	181	408	5	60	1	4	0.08
PMC225EUM	41	45 000	2.3	25	5	65	0.3	4	0.17
PMC225EUMH	41	45 000	23	230	5	65	0.3	4	0.17
PMC225EUMH2	41	45 000	180	910	5	65	0.3	4	0.17
PMC225EUMH3	41	45 000	816	1 814	5	65	0.3	4	0.17
PMC600EUM	136	68 000	9	136	5	85	0.6	2	0.32
PMC600EUMH	136	68 000	113	1 130	5	85	0.6	2	0.32
PMC600EUMH2	136	68 000	400	2 300	5	85	0.6	2	0.32
PMC600EUMH3	136	68 000	2 177	4 536	5	85	0.6	2	0.32

Type

PMC150EUM-V4A	20	34 000	0.9	10	5	60	0.4	4	0.08
PMC150EUMH-V4A	20	34 000	8.6	86	5	60	0.4	4	0.08
PMC150EUMH2-V4A	20	34 000	70	200	5	60	0.4	4	0.08
PMC150EUMH3-V4A	20	34 000	181	408	5	60	1	4	0.08
PMC225EUM-V4A	41	45 000	2.3	25	5	65	0.3	4	0.17
PMC225EUMH-V4A	41	45 000	23	230	5	65	0.3	4	0.17
PMC225EUMH2-V4A	41	45 000	180	910	5	65	0.3	4	0.17
PMC225EUMH3-V4A	41	45 000	816	1 814	5	65	0.3	4	0.17
PMC600EUM-V4A	136	68 000	9	136	5	85	0.6	2	0.32
PMC600EUMH-V4A	136	68 000	113	1 130	5	85	0.6	2	0.32
PMC600EUMH2-V4A	136	68 000	400	2 300	5	85	0.6	2	0.32
PMC600EUMH3-V4A	136	68 000	2 177	4 536	5	85	0.6	2	0.32

Issue 6.2011 Specifications subject to change

ACE miniature shock absorbers are maintenance-free, self-contained hydraulic components. The SC-Series provide dual performance benefits. They provide “soft contact” deceleration where initial impact reaction forces are very low with the advantages of self-compensation to cope with changing input energy conditions without adjustment. They have long stroke lengths to provide smooth deceleration and low reaction forces. They have an integrated mechanical stop and are ideal for use on handling equipment, linear transfers, rodless cylinders and pneumatic pick and place systems etc. The overlapping operating ranges enable the SC series to handle effective weights ranging 0.7 kg up to 2088 kg. With the optional side load adaptor fitted they can cope with the side loads up to 25°.

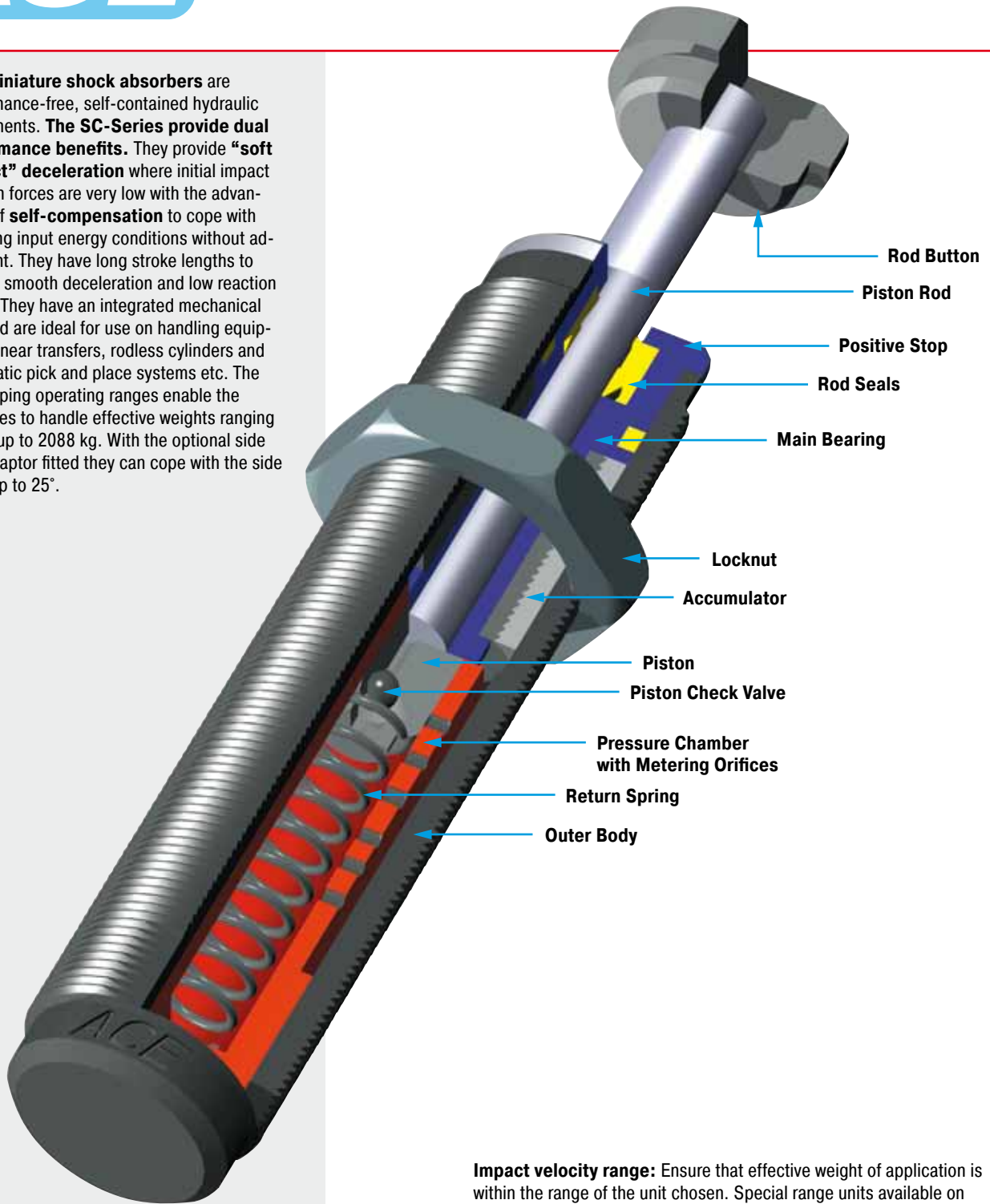

Impact velocity range: Ensure that effective weight of application is within the range of the unit chosen. Special range units available on request.

Material: Shock absorber body: Nitride hardened steel. Accessories: Steel with black oxide finish or nitride hardened. Piston rod: Hardened stainless steel.

W₄ capacity rating: (max. energy per hour Nm/hr) If your application exceeds the tabulated W₄ figures consider additional cooling i. e. cylinder exhaust air etc. Ask ACE for further details.

Mounting: In any position. If precise end position datum is required consider use of the optional stop collar type AH.

Operating temperature range: 0 °C to 66 °C

On request: Weartec finish (seawater resistant). Other special finishes available to special order.



SC190EUM

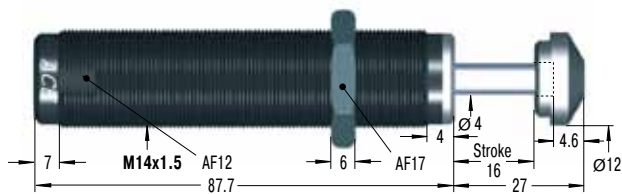

M14x1 and M16x1 also available to special order
Accessories, mounting, installation ... see pages 37 to 41.

SC300EUM

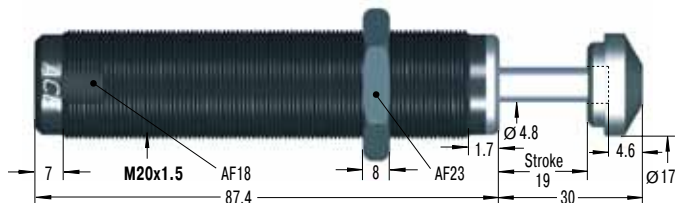

M22x1.5 also available to special order
Accessories, mounting, installation ... see pages 38 to 41.

SC650EUM

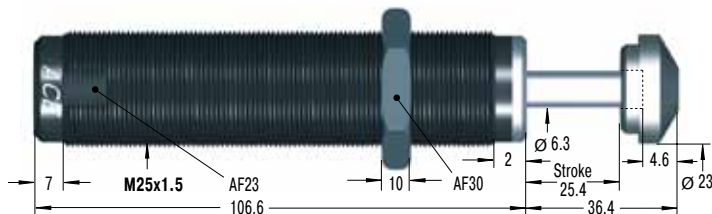

M26x1.5 also available to special order
Accessories, mounting, installation ... see pages 38 to 41.

SC925M

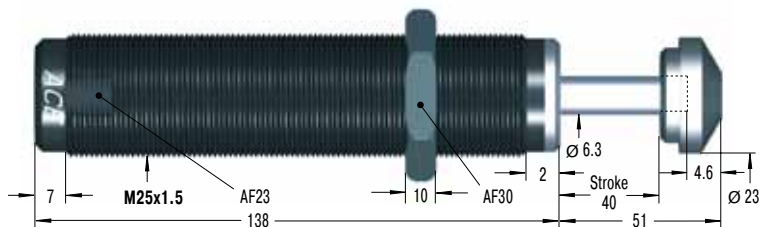

Accessories, mounting, installation ... see pages 38 to 41.

Available without rod end button on request.

Capacity Chart

Type Part Number	Max. Energy Capacity		Effective Weight me				Min. Return Force N	Max. Return Force N	Rod Reset Time s	1 Max. Side Load Angle °	Weight kg
	W ₃ Nm/Cycle	W ₄ Nm/h	Soft-Contact me min. kg	Soft-Contact me max. kg	Self-Compensating me min. kg	Self-Compensating me max. kg					
SC190EUM-0	25	34 000	—	—	0.7	4	4	9	0.25	5	0.08
SC190EUM-1	25	34 000	2.3	6	1.4	7	4	9	0.25	5	0.08
SC190EUM-2	25	34 000	5.5	16	3.6	18	4	9	0.25	5	0.08
SC190EUM-3	25	34 000	14	41	9	45	4	9	0.25	5	0.08
SC190EUM-4	25	34 000	34	91	23	102	4	9	0.25	5	0.08
SC300EUM-0	33	45 000	—	—	0.7	4	5	10	0.1	5	0.11
SC300EUM-1	33	45 000	2.3	7	1.4	8	5	10	0.1	5	0.11
SC300EUM-2	33	45 000	7	23	4.5	27	5	10	0.1	5	0.11
SC300EUM-3	33	45 000	23	68	14	82	5	10	0.1	5	0.11
SC300EUM-4	33	45 000	68	181	32	204	5	10	0.1	5	0.11
SC650EUM-0	73	68 000	—	—	2.3	14	11	32	0.2	5	0.31
SC650EUM-1	73	68 000	11	36	8	45	11	32	0.2	5	0.31
SC650EUM-2	73	68 000	34	113	23	136	11	32	0.2	5	0.31
SC650EUM-3	73	68 000	109	363	68	408	11	32	0.2	5	0.31
SC650EUM-4	73	68 000	363	1 089	204	1 180	11	32	0.2	5	0.31
SC925EUM-0	110	90 000	8	25	4.5	29	11	32	0.4	5	0.39
SC925EUM-1	110	90 000	22	72	14	90	11	32	0.4	5	0.39
SC925EUM-2	110	90 000	59	208	40	272	11	32	0.4	5	0.39
SC925EUM-3	110	90 000	181	612	113	726	11	32	0.4	5	0.39
SC925EUM-4	110	90 000	544	1 952	340	2 088	11	32	0.4	5	0.39

1 For applications with higher side load angles consider using the side load adaptor (BV) pages 37 to 40.

RF14

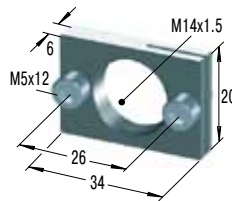

Rectangular Flange

MB14

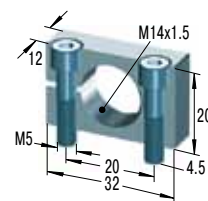

Clamp Mount

RF20

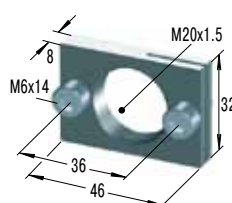

Rectangular Flange

MB20

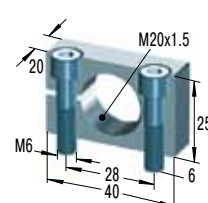

Clamp Mount

RF25

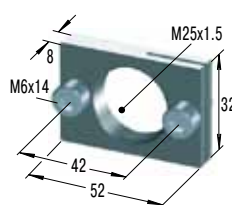

Rectangular Flange

MB25

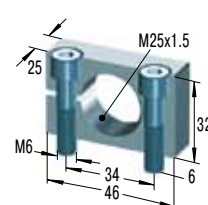

Clamp Mount

RF25

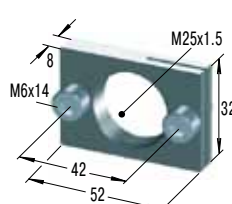

Rectangular Flange

MB25

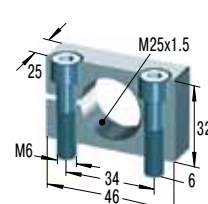

Clamp Mount

ACE miniature shock absorbers are maintenance-free, self-contained hydraulic components. The design of the **SC²-Series** units combines the piston and inner tube into a single component and **provides more than double the energy capacity of previous units in the same envelope size**. They have an integrated mechanical stop and are ideal for use on handling equipment, linear transfers, rodless cylinders, pneumatic pick and place systems and rotation modules etc. The smaller sizes up to type SC²190, have a dynamic membrane seal which allows direct installation into the end cover of pneumatic cylinders (for end position damping max. 7 bar). The greatly increased energy capacity coupled with overlapping effective weight ranges covering from 1 kg up to 6350 kg makes the SC²-Series units ideal for rotary actuators. With the optional side load adaptor fitted they can cope with the side loads up to 25°.

"Combined piston and inner tube – increased energy capacity up to 200 %!"

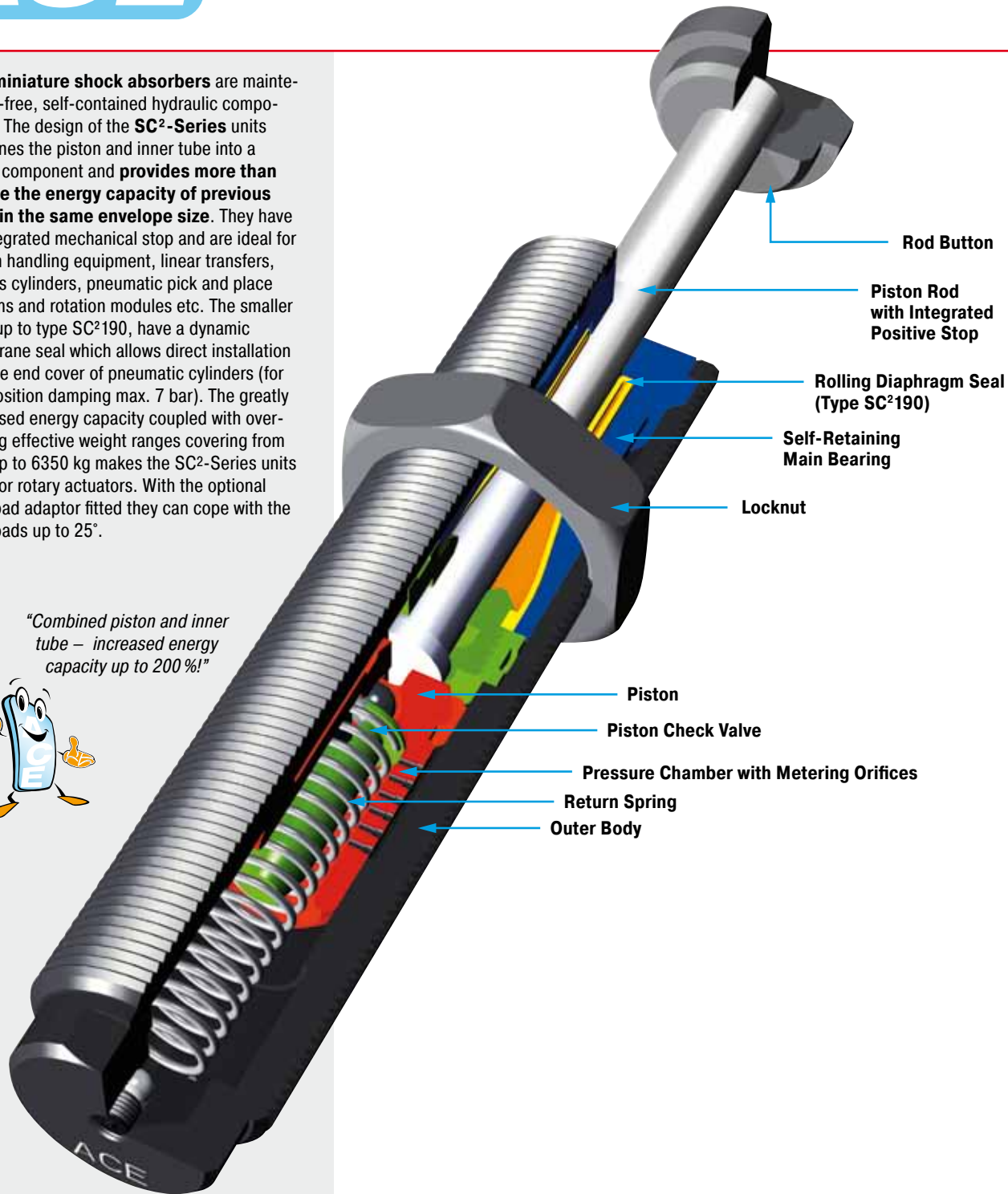

Rod Button

Piston Rod with Integrated Positive Stop

Rolling Diaphragm Seal (Type SC²190)

Self-Retaining Main Bearing

Locknut

Piston

Piston Check Valve

Pressure Chamber with Metering Orifices

Return Spring

Outer Body

Impact velocity range: Ensure that effective weight of application is within the range of the unit chosen. Special range units available on request.

Material: Shock absorber body: Nitride hardened steel. Accessories: Steel with black oxide finish or nitride hardened. Piston rod: Hardened stainless steel.

Mounting: In any position. If precise end position datum is required consider use of the optional stop collar type AH.

Operating temperature range: 0 °C to 66 °C

On request: Weartec finish (seawater resistant). Other special finishes available to special order.



SC25EUM

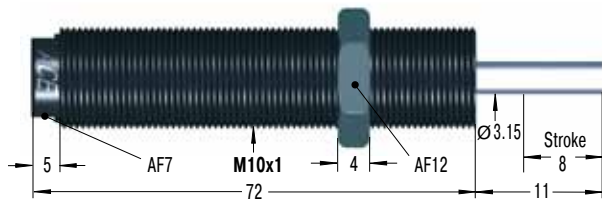

Accessories, mounting, installation ... see pages 36 to 41.

SC75EUM

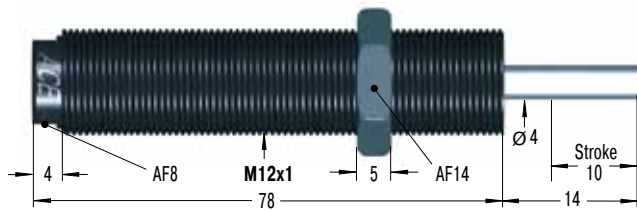

Accessories, mounting, installation ... see pages 37 to 41.

SC190EUM

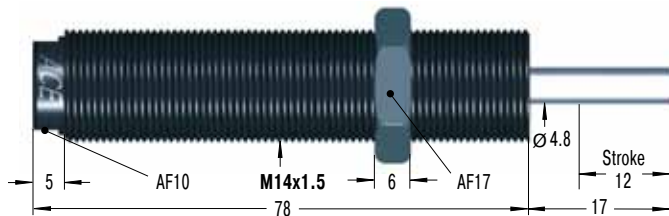

M14x1 also available to special order

Accessories, mounting, installation ... see pages 37 to 41.

SC300EUM

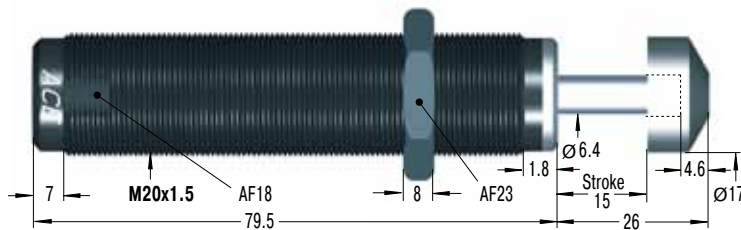

Accessories, mounting, installation ... see pages 38 to 41.

SC650EUM

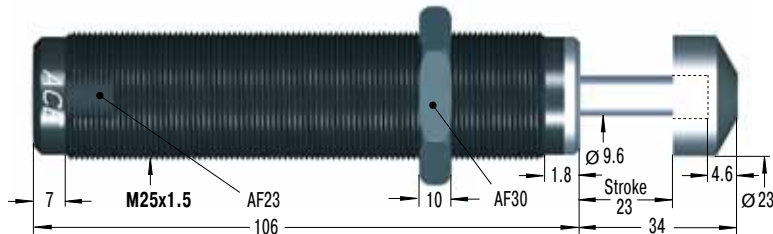

Accessories, mounting, installation ... see pages 38 to 41.

RF10

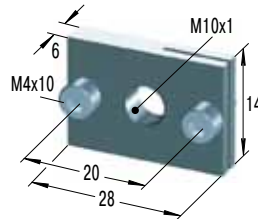

Rectangular Flange

MB10SC2

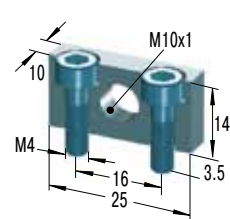

Mounting Block

RF12

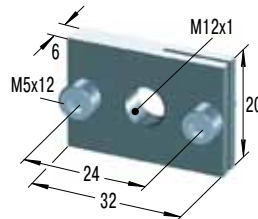

Rectangular Flange

MB12SC2

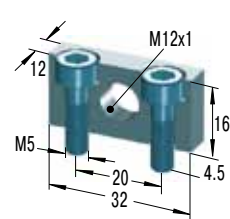

Mounting Block

RF14

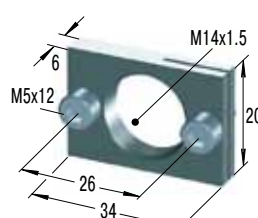

Rectangular Flange

MB14SC2

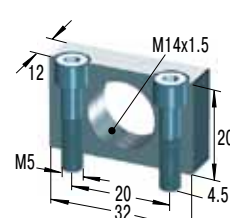

Mounting Block

RF20

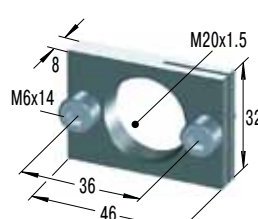

Rectangular Flange

MB20SC2

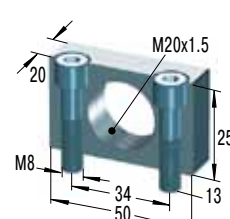

Mounting Block

RF25

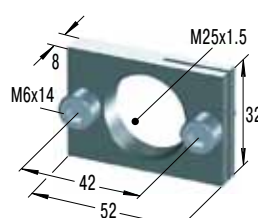

Rectangular Flange

MB25SC2

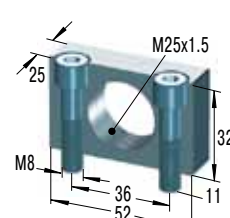

Mounting Block

Capacity Chart

Type	Max. Energy Capacity		Effective Weight me					Min. Return Force N	Max. Return Force N	Rod Reset Time s	1 Max. Side Load Angle °	Weight kg
	W ₃ Nm/Cycle	W ₄ Nm/h	Soft		Hard							
			-5 min. kg	-6 max. kg	-7 min. kg	-8 max. kg	-9 min. kg					
SC25EUM	10	16 000	1 - 5	4 - 44	42 - 500	-	-	4.5	14	0.3	2	0.027
SC75EUM	16	30 000	1 - 8	7 - 78	75 - 800	-	-	6	19	0.3	2	0.045
SC190EUM	31	50 000	2 - 16	13 - 140	136 - 1 550	-	-	6	19	0.4	2	0.060
SC300EUM	73	45 000	11 - 45	34 - 136	91 - 181	135 - 680	320 - 1 950	8	18	0.2	5	0.164
SC650EUM	210	68 000	23 - 113	90 - 360	320 - 1 090	770 - 2 630	1 800 - 6 350	11	33	0.3	5	0.315

1 For applications with higher side load angles consider using the side load adaptor (BV) pages 36 to 40.

Issue 6.2011 Specifications subject to change

ACE miniature shock absorbers are maintenance-free, self-contained hydraulic components. If you prefer a fully adjustable shock absorber rather than a self-compensating model on your application then the **MA series** provide a directly interchangeable alternative. The adjustable series include an integrated mechanical stop. These adjustable units have long stroke lengths (MA900 with 40 mm super-stroke) to provide smooth deceleration and low reaction forces. The MA150 incorporates the proven rolling diaphragm seal (used on the MC150 to MC600 range) and shares all the advantages of that technology. The stepless adjustment range of the MA series covers an effective weight range from 0.2 kg up to 2040 kg.

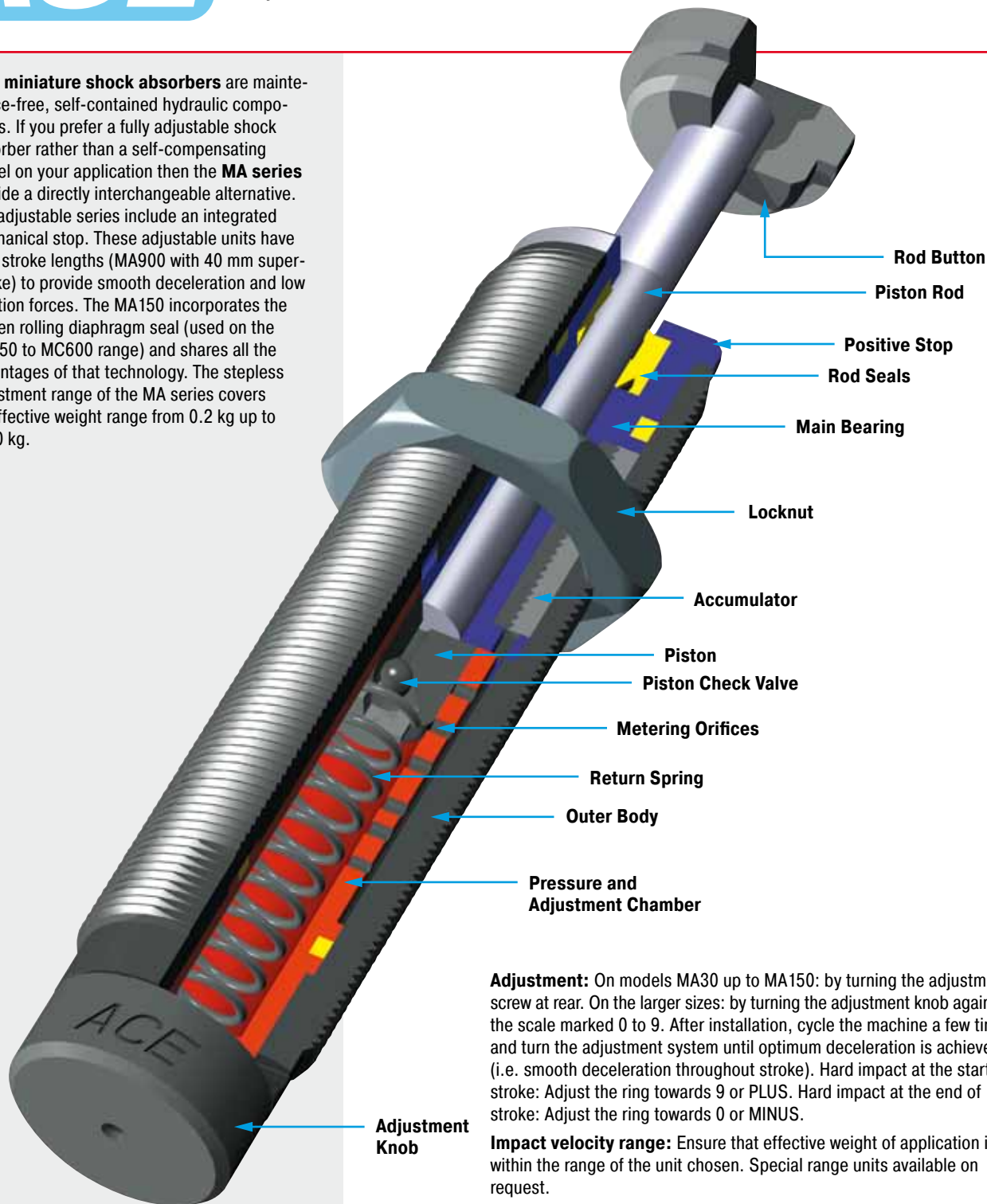

Adjustment: On models MA30 up to MA150: by turning the adjustment screw at rear. On the larger sizes: by turning the adjustment knob against the scale marked 0 to 9. After installation, cycle the machine a few times and turn the adjustment system until optimum deceleration is achieved (i.e. smooth deceleration throughout stroke). Hard impact at the start of stroke: Adjust the ring towards 9 or PLUS. Hard impact at the end of stroke: Adjust the ring towards 0 or MINUS.

Impact velocity range: Ensure that effective weight of application is within the range of the unit chosen. Special range units available on request.

Material: Shock absorber body: Nitride hardened steel. Accessories: Steel with black oxide finish or nitride hardened. Piston rod: Hardened stainless steel.

W₄ capacity rating: (max. energy per hour Nm/hr) If your application exceeds the tabulated W₄ figures consider additional cooling i. e. cylinder exhaust air etc. Ask ACE for further details.

Mounting: In any position. If precise end position datum is required consider use of the optional stop collar type AH. Install a mechanical stop 0.5 to 1 mm before end of stroke on FA1008.

Operating temperature range: 0 °C to 66 °C

On request: Weartec finish (seawater resistant). Other special finishes available to special order.



MA30EUM

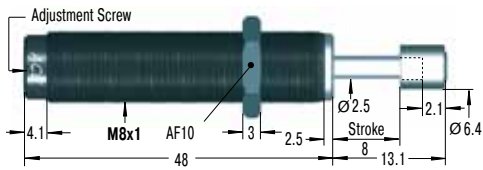

Accessories, mounting, installation ... see pages 36 to 41.

MA50EUM for use on new installations

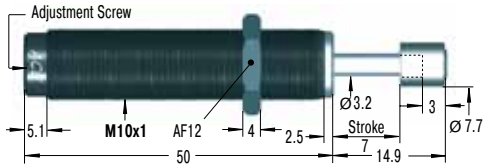

Accessories, mounting, installation ... see pages 36 to 41.

MA35EUM

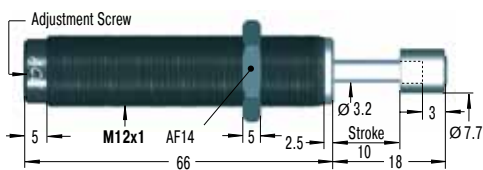

Accessories, mounting, installation ... see pages 37 to 41.

MA150EUM

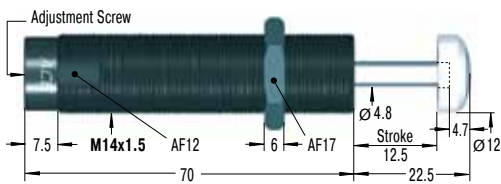

M14x1 also available to special order

Accessories, mounting, installation ... see pages 37 to 41.

MA225EUM

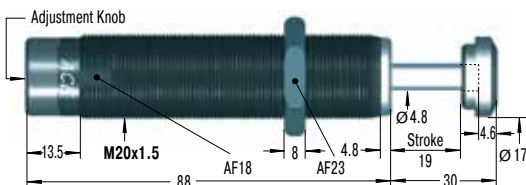

Accessories, mounting, installation ... see pages 38 to 41.

MA600EUM and MA900EUM

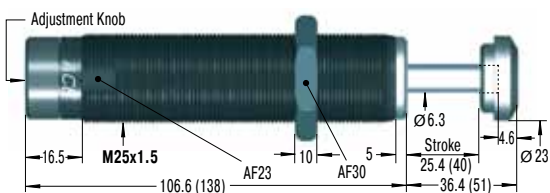

Dimensions for MA900EUM in ()

MA600EUM with M27x3 available to special order

Accessories, mounting, installation ... see pages 38 to 41.

RF8

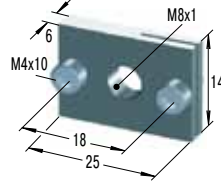

Rectangular Flange

MB8SC2

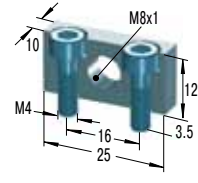

Mounting Block

FA1008VD-B still available in future

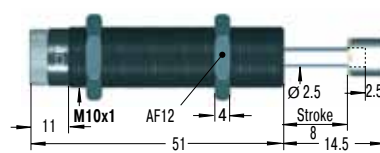

Accessories, mounting, installation ... see pages 36 to 41.

RF12

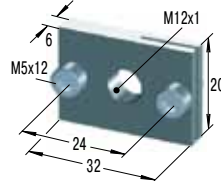

Rectangular Flange

MB12

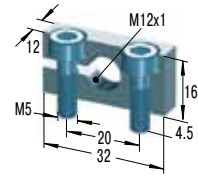

Clamp Mount

RF14

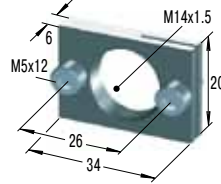

Rectangular Flange

MB14

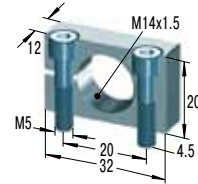

Clamp Mount

RF20

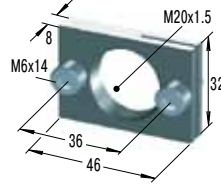

Rectangular Flange

MB20

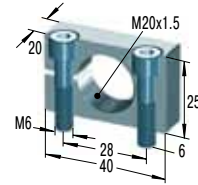

Clamp Mount

RF25

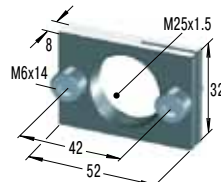

Rectangular Flange

MB25

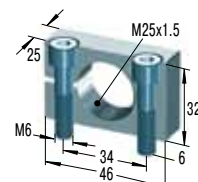

Clamp Mount

Available without rod end button on request. Models MA600EUM/MA900EUM available with clevis mounting.

Capacity Chart

Type Part Number	Max. Energy Capacity		Effective Weight me Adjustable		Min. Return Force N	Max. Return Force N	Rod Reset Time s	1 Max. Side Load Angle °	Weight kg
	W ₃ Nm/Cycle	W ₄ Nm/h	me min. kg	me max. kg					
MA30EUM	3.5	5 650	0.23	15	1.7	5.3	0.3	2	0.013
FA1008VD-B	1.8	3 600	0.2	10	3	6	0.3	2.5	0.026
MA50EUM	5.5	13 550	4.5	20	3	6	0.3	2	0.025
MA35EUM	4	6 000	6	57	5	11	0.2	2	0.043
MA150EUM	22	35 000	1	109	3	5	0.4	2	0.06
MA225EUM	25	45 000	2.3	226	5	10	0.1	2	0.13
MA600EUM	68	68 000	9	1 360	10	30	0.2	2	0.31
MA900EUM	100	90 000	14	2 040	10	35	0.4	1	0.4

1 For applications with higher side load angles consider using the side load adaptor (BV) pages 36 to 40.

Selection Chart for Shock Absorber Accessories



Locknut



Stop Collar



¹ Clamp Mount/
Mounting Block



Rectangular Flange



Universal Mount



² Side Load
Adaptor

Shock Absorber Type

KM

AH

MB

RF

UM

BV

Thread Size M5x0.5

MC5EUM	KM5	AH5	MB5SC2	-	-	-
--------	-----	-----	--------	---	---	---

Thread Size M6x0.5

MC9EUM	KM6	AH6	MB6SC2	RF6	-	-
--------	-----	-----	--------	-----	---	---

Thread Size M8x1

MA30EUM	KM8	AH8	MB8SC2	RF8	-	BV8
MC10EUM	KM8	AH8	MB8SC2	RF8	-	BV8A
MC30EUM	KM8	AH8	MB8SC2	RF8	-	BV8

Thread Size M10x1

FA1008VD-B	KM10	AH10	MB10SC2	RF10	UM10	-
MA50EUM	KM10	AH10	MB10SC2	RF10	UM10	BV10
MC25EUM	KM10	AH10	MB10SC2	RF10	UM10	BV10
SC25EUM	KM10	AH10	MB10SC2	RF10	UM10	BV10SC

Thread Size M12x1

MA35EUM	KM12	AH12	MB12	RF12	UM12	BV12
MC75EUM	KM12	AH12	MB12	RF12	UM12	BV12
SC75EUM	KM12	AH12	MB12SC2	RF12	UM12	BV12SC

Thread Size M14x1.5

MA150EUM	KM14	AH14	MB14	RF14	UM14	BV14
MC150EUM	KM14	AH14	MB14	RF14	UM14	BV14
SC190EUM0-4	KM14	AH14	MB14	RF14	UM14	BV14SC
SC190EUM5-7	KM14	AH14	MB14SC2	RF14	UM14	BV14

Thread Size M20x1.5

MA225EUM	KM20	AH20	MB20	RF20	UM20	BV20SC
MC225EUM	KM20	AH20	MB20	RF20	UM20	BV20
SC300EUM0-4	KM20	AH20	MB20	RF20	UM20	BV20SC
SC300EUM5-9	KM20	AH20	MB20SC2	RF20	UM20	BV20SC

Thread Size M25x1.5

MA600EUM	KM25	AH25	MB25	RF25	UM25	BV25SC
MA900EUM	KM25	AH25	MB25	RF25	UM25	-
MC600EUM	KM25	AH25	MB25	RF25	UM25	BV25
SC650EUM0-4	KM25	AH25	MB25	RF25	UM25	BV25SC
SC650EUM5-9	KM25	AH25	MB25SC2	RF25	UM25	BV25SC
SC925EUM	KM25	AH25	MB25	RF25	UM25	-

¹ Use a locknut for protection if a clamp mount MB...SC2 is installed.

² Only mountable on units without button.
Remove the button from the shock absorber, if there's one fitted. See page 40.



² Steel Shroud



Air Bleed Collar



Switch Stop Collar



Steel Button



Steel/Urethane Button



Nylon Button

	PB	SP	AS	PS	BP	PP	Page
Thread Size M5x0.5	-	-	-	-	-	-	36
Thread Size M6x0.5	-	-	-	-	-	-	36
Thread Size M8x1							
PB8	-	-	-	-	-	-	36
PB8-A	-	-	-	-	-	-	36
PB8	-	-	-	-	-	-	36
Thread Size M10x1							
-	-	-	-	-	-	-	36
PB10	-	-	AS10	PS10	-	-	36
PB10	-	-	AS10	PS10	-	-	36
PB10SC	-	-	-	-	-	-	36
Thread Size M12x1							
PB12	-	-	AS12	PS12	-	-	37
PB12	-	-	AS12	PS12	-	-	37
PB12SC	SP12	-	AS12	PS12SC	-	-	37
Thread Size M14x1.5							
PB14	SP14	-	AS14	PS14	-	included	37
PB14	SP14	-	AS14	PS14	-	PP150	37
PB14SC	-	-	AS14	included	BP14	-	37
PB14	SP14	-	AS14	PS14	-	-	37
Thread Size M20x1.5							
PB20SC	-	-	AS20	included	BP20	-	38
PB20	SP20	-	AS20	PS20	-	PP225	38
PB20SC	-	-	AS20	included	BP20	-	38
PB20SC	-	-	AS20	included	-	-	38
Thread Size M25x1.5							
PB25SC	-	-	AS25	included	BP25	-	38
-	-	-	AS25	included	BP25	-	38
PB25	SP25	-	AS25	PS25	-	PP600	38
PB25SC	-	-	AS25	included	BP25	-	38
PB25	-	-	AS25	included	-	-	38
-	-	-	AS25	included	BP25	-	38

² Only mountable on units without button.
Remove the button from the shock absorber, if there's one fitted. See page 40.

Dimensions see pages 36 to 38.

M5x0.5

KM5

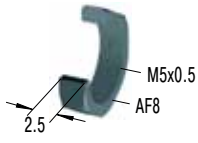

Locknut

AH5

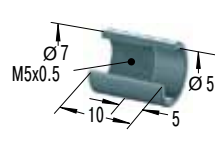

Stop Collar

MB5SC2

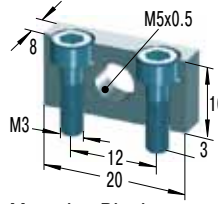

Mounting Block

M6x0.5

KM6



Locknut

AH6

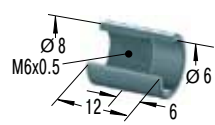

Stop Collar

MB6SC2

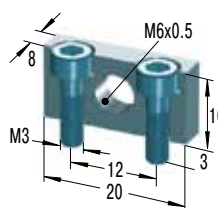

Mounting Block

RF6

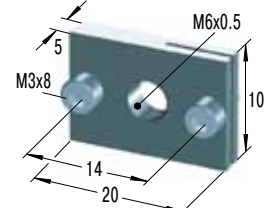

Rectangular Flange

M8x1

KM8



Locknut

AH8

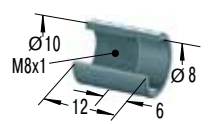

Stop Collar

MB8SC2

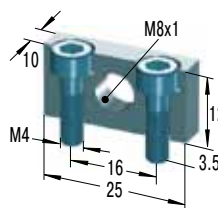

Mounting Block

RF8

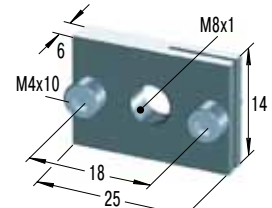

Rectangular Flange

BV8

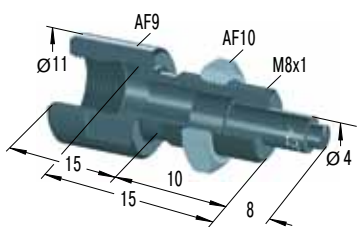

Side Load Adaptor

BV8A

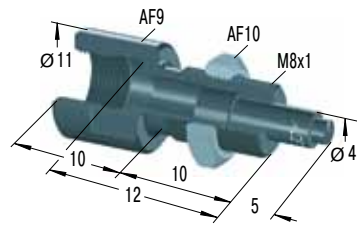

Side Load Adaptor

PB8

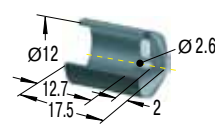

Steel Shroud

PB8-A

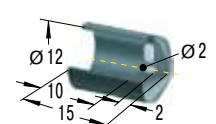

Steel Shroud

M10x1

KM10



Locknut

AH10

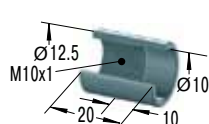

Stop Collar

MB10SC2

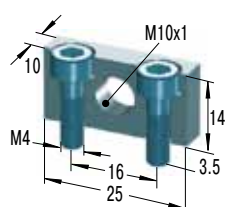

Mounting Block

RF10

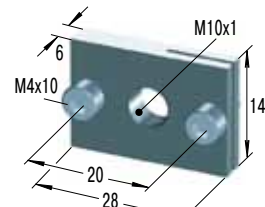

Rectangular Flange

UM10

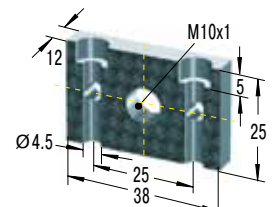

Universal Mount

BV10

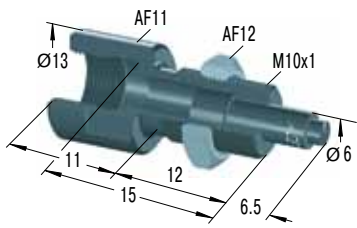

Side Load Adaptor

PB10

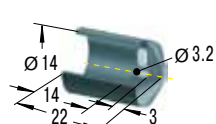

Steel Shroud

PB10SC

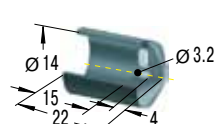

Steel Shroud

AS10

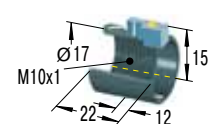

Switch Stop Collar
inc. Proximity Switch

PS10

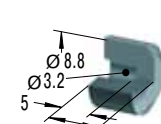

Steel Button

Mounting, installation... see pages 39 to 41.

M12x1

KM12



Locknut

AH12

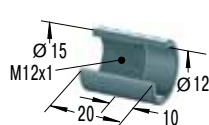

Stop Collar

MB12

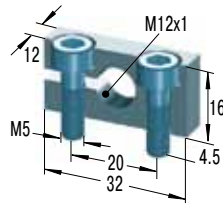

Clamp Mount

MB12SC2

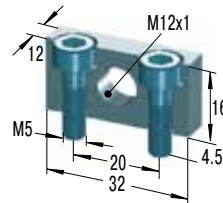

Mounting Block

RF12

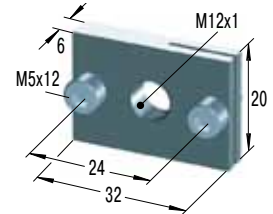

Rectangular Flange

UM12

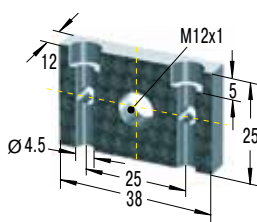

Universal Mount

BV12

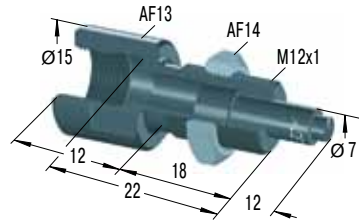

Side Load Adaptor

BV12SC

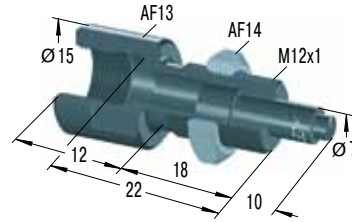

Side Load Adaptor

PB12

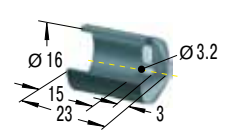

Steel Shroud

PB12SC

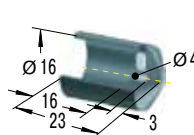

Steel Shroud

SP12

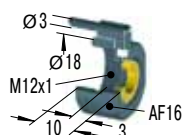

Air Bleed Collar

AS12

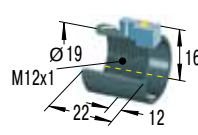

Switch Stop Collar
inc. Proximity Switch

PS12

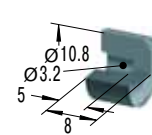

Steel Button

PS12SC

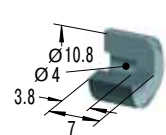

Steel Button

M14x1.5

KM14



Locknut

AH14

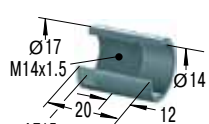

Stop Collar

MB14

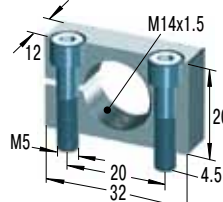

Clamp Mount

MB14SC2

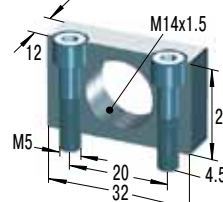

Mounting Block

RF14

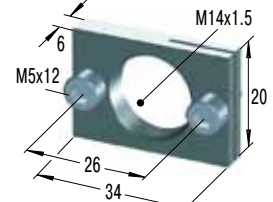

Rectangular Flange

UM14

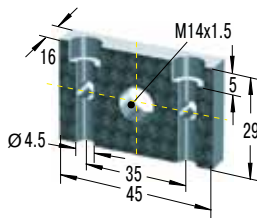

Universal Mount

BV14

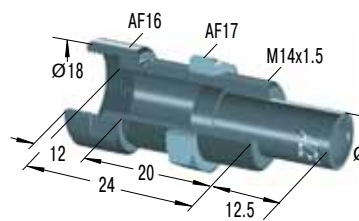

Side Load Adaptor

BV14SC

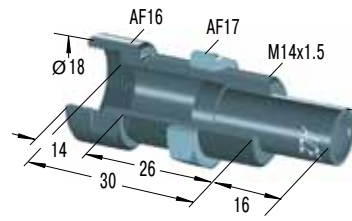

Side Load Adaptor

PB14

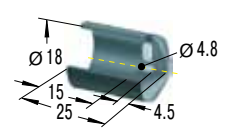

Steel Shroud

PB14SC

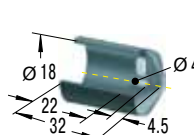

Steel Shroud

SP14

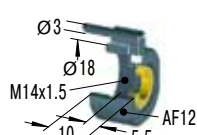

Air Bleed Collar

AS14

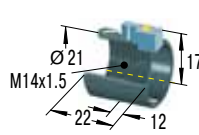

Switch Stop Collar
inc. Proximity Switch

PS14

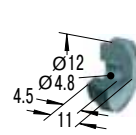

Steel Button

BP14

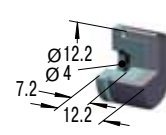

Steel/Urethane
Button

PP150

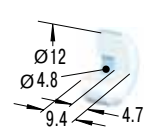

Nylon Button
W₃ max = 14 Nm

M20x1.5

KM20



Locknut

AH20

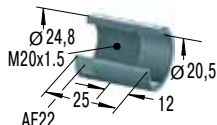

Stop Collar

MB20

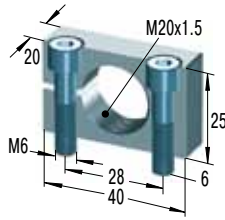

Clamp Mount

MB20SC2

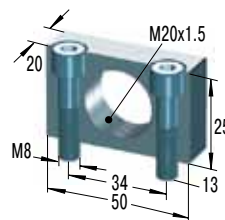

Mounting Block

RF20

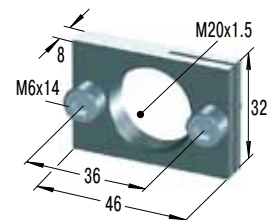

Rectangular Flange

UM20

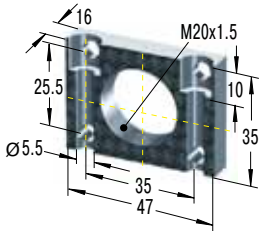

Universal Mount

BV20

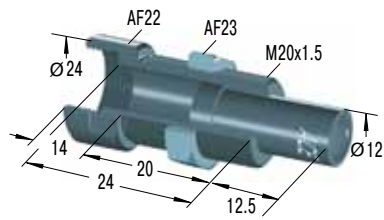

Side Load Adaptor

BV20SC

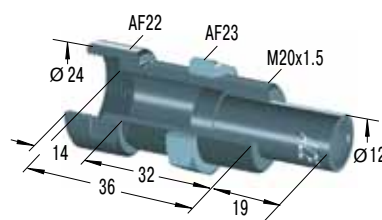

Side Load Adaptor

PB20

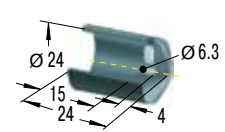

Steel Shroud

PB20SC

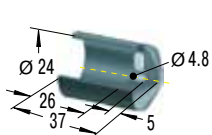

Steel Shroud

SP20

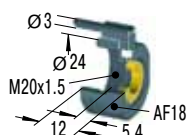

Air Bleed Collar

AS20

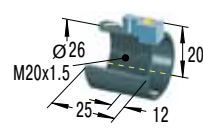

Switch Stop Collar
inc. Proximity Switch

PS20

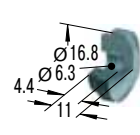

Steel Button

BP20

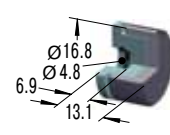

Steel/Urethane
Button

PP225

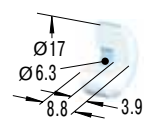

Nylon Button
W₃ max = 33 Nm

M25x1.5

KM25

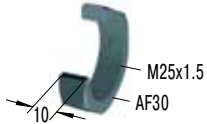

Locknut

AH25

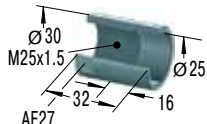

Stop Collar

MB25

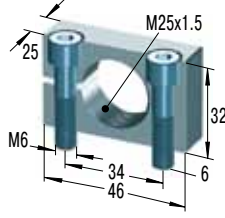

Clamp Mount

MB25SC2

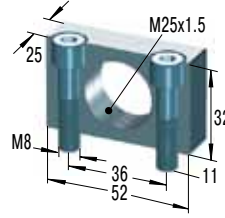

Mounting Block

RF25

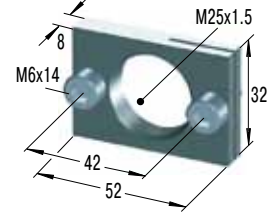

Rectangular Flange

UM25

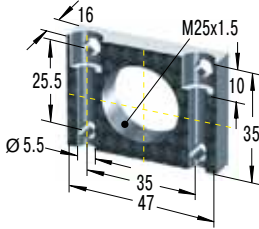

Universal Mount

BV25

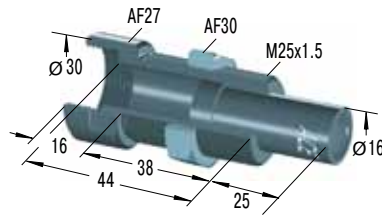

Side Load Adaptor

BV25SC

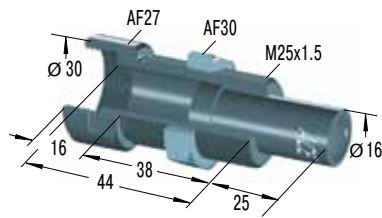

Side Load Adaptor

PB25

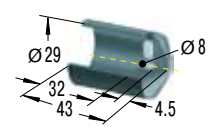

Steel Shroud

PB25SC

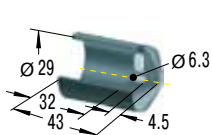

Steel Shroud

SP25

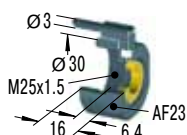

Air Bleed Collar

AS25

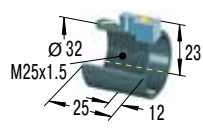

Switch Stop Collar
inc. Proximity Switch

PS25

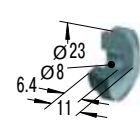

Steel Button

BP25

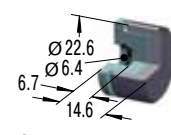

Steel/Urethane
Button

PP600

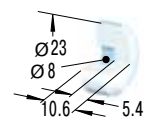

Nylon Button
W₃ max = 68 Nm

Mounting, installation... see pages 39 to 41.

AH Stop Collar

All ACE miniature shock absorbers (except FA series) have an **integral positive stop**. An **optional stop collar (AH...)** can be added if desired to give fine adjustment of final stopping position.

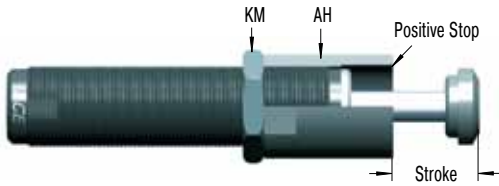

MB Clamp Mount/Mounting Block

When using the MB clamp mount no locknut is needed on the shock absorber (split clamp action). The mounting block is very compact and allows fine adjustment of the shock absorber position by turning in and out. Two socket head screws are included with clamp mount block. **When foot mounting the types with combined piston and inner tube SC²25EUM to SC²650EUM and the types MC5EUM, MC9EUM, MC30EUM, MC25EUM and MA30EUM, the MB (SC²) must be used.**



Clamp slot design not for use with SC²

Type	Screw Size	Max. Torque	Type	Screw Size	Max. Torque
MB10	M4x14	4 Nm	MB20	M6x25	11 Nm
MB12	M5x16	6 Nm	MB25	M6x30	11 Nm
MB14	M5x20	6 Nm			

RF Rectangular Flange

The rectangular flange RF provides a space saving convenient assembly and does not need a lock nut to hold the shock absorber. Therefore achieving a neat, compact and flat surface mounting.



Type	Screw Size	Max. Torque	Type	Screw Size	Max. Torque
RF6	M3x8	3 Nm	RF14	M5x12	6 Nm
RF8	M4x10	4 Nm	RF20	M6x14	11 Nm
RF10	M4x10	4 Nm	RF25	M6x14	11 Nm
RF12	M5x12	6 Nm			

PB Steel Shroud

Grinding beads, sand, welding splatter, paints and adhesives etc. can adhere to the piston rod. They then damage the rod seals and the shock absorber quickly fails. In many cases the installation of the optional steel shroud can provide worthwhile protection and increase lifetime.

Note! When installing don't forget to allow operating space for the shroud to move as the shock absorber is cycled. For part number MA, MC, SC please order with „M-880“ suffix. Part numbers MA150EUM, MC150EUM to MC600EUM and SC25EUM to SC190EUM5-7 are supplied without a button, for advice on removing the button see page 40.

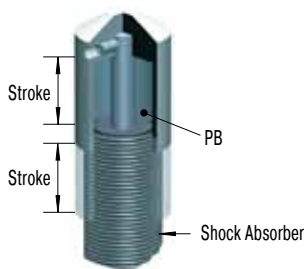

SP Air Bleed Collar

Air bleed collar (includes integral stop collar) protects shock absorber from ingress of abrasive contaminants like cement, paper or wood dust into the rod seal area. It also prevents aggressive fluids such as cutting oils, coolants etc. damaging the seals. Air bleed supply 0.5 to 1 bar. Low air consumption. The constant air bleed prevents contaminants passing the wiper ring and entering the shock absorber seal area.

Note! Do not switch off air supply whilst machine is operating! The air bleed collar cannot be used on all similar body thread sized shock absorbers. The air bleed collar is only for types MC150EUM to MC600EUM, MA150EUM, SC75EUM and SC190EUM5-7.

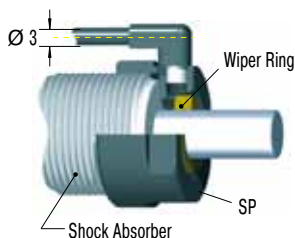

BV / BV...SC Side Load Adaptor

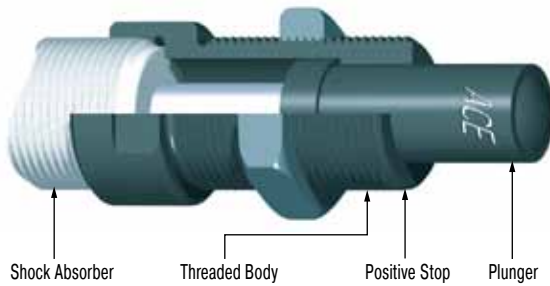

With side load impact angles of more than 3° the operation lifetime of the shock absorber reduces rapidly due to increased wear of the rod bearings. The optional BV side load adaptor provides long lasting solution. Secure the side load adaptor with Loctite or locknut on the shock absorber.

Material: Threaded body and plunger: Hardened high tensile steel. Hardened 610 HV1.

Note: For material combination plunger/impact plate use similar hardness values. We recommend that you install the shock absorber/side load adaptor using the thread on the side load adaptor.

Note! Installation with clamp mount MB... not possible. Use mounting block MB... SC².

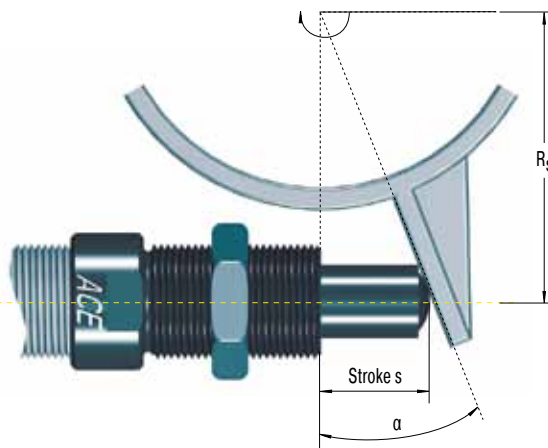

Problem: Rotating impact motion causes high side load forces on the piston rod. This increases bearing wear and possibly results in rod breakage or bending.

Solution: Install side load adaptor BV.

Formulae:

$$\alpha = \tan^{-1} \left(\frac{s}{R_s} \right) \quad R_{s \min} = \frac{s}{\tan \alpha \max}$$

Example:

s = 0.025 m

$\alpha \max = 25^\circ$ (Type BV25)

$R_s = 0.1$ m

$$\alpha = \tan^{-1} \left(\frac{0.025}{0.1} \right) \quad R_{s \min} = \frac{0.025}{\tan 25}$$

$\alpha = 14.04^\circ \quad R_{s \min} = 0.054$ m

α = side load angle ° R_s = mounting radius m
 $\alpha \max$ = max. angle ° $R_{s \min}$ = min. possible mounting radius m
s = absorber stroke m

Maximum angle:

BV8, BV10 and BV12 = 12.5°

BV14, BV20 and BV25 = 25°

Note: By repositioning the centre of the stroke of the side load plunger to be at 90 degrees to the piston rod, the side load angle can be halved. The use of an external positive stop due to high forces encountered is required.

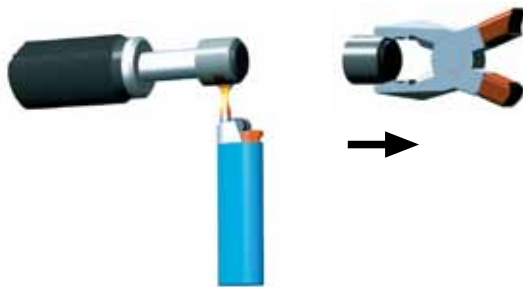

Time required for warming up the button:

up to M12x1: approx. 10 sec.
from M14x1.5 up: approx. 30 sec.

Note! The BV adaptor can only be installed onto a shock absorber without rod end button.

Part Number: MA, MC, SC...-880

(Models MC150EUM to MC600EUM and SC²25EUM to SC²190EUM5-7 are supplied as standard without buttons.)

To remove button from existing absorber: Clamp shock absorber in mounting block and warm button carefully. Grip the button with pliers and pull off along rod axis.

PP Nylon Button

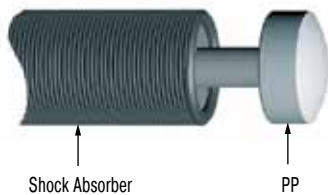

While the use of industrial shock absorbers already achieves a considerable reduction in noise levels, the additional use of PP impact buttons made of glass fibre reinforced nylon reduces noise levels even further, making it easy to fulfil the regulations of the new Noise Control Ordinance. At the same time, wear of impact surface is drastically minimized. The PP buttons are available for shock absorbers in series MC150EUM to MC600EUM. Model MA150EUM is supplied as standard with PP button. The buttons are fitted simply by pressing onto the piston rod.

BP Steel/Urethane Button



These new impact buttons made of urethane offer all above advantages of the PP nylon button in terms of reducing noise and wear. They fit easily onto the piston rod of the corresponding shock absorber. The head is then secured by a circlip integrated in the drilled hole of the steel base material. Please refer to the accessories table on pages 34 to 35 to see which shock absorber types the new BP buttons are available for.

PS / AS Steel Button, Switch Stop Collar

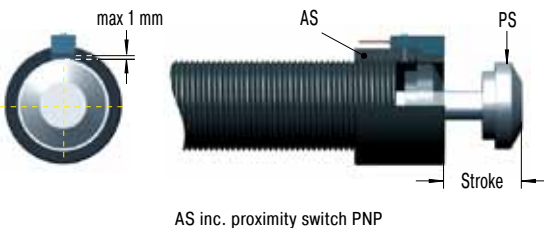

The ACE stop light switch stop collar combination can be mounted on all popular shock absorber models.

Features: Very short, compact mounting package.

The steel button type PS is fitted as standard on the models: SC190EUM0-4, SC300EUM0-9, SC650EUM0-9, SC925EUM0-4, MA/MVC225EUM, MA/MVC600EUM and MA/MVC900EUM. With all other models you must order the PS button as an optional accessory.

Mounting: We recommend to fix the steel button onto the end of the piston rod using Loctite 290. Attention! Take care not to leave any adhesive on the piston rod as this will cause seal damage. Thread the switch stop collar onto the front of the shock absorber and secure in position. Switch cable should not be routed close to power cables.

250-3 PNP Proximity Switch

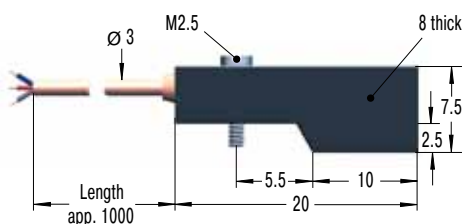

PNP proximity switch data:

- Supply voltage: 10-27 VDC
- Ripple < 10%
- Load current max.: 100 mA
- Operating temperature range: -10 °C to +60 °C
- Residual voltage: max. 1 V
- Protection: IP67 (IEC 144) with LED-indicator
- Proximity switch N/Open when shock absorber extended.
- When shock absorber is fully compressed switch closes and LED indicator lights.

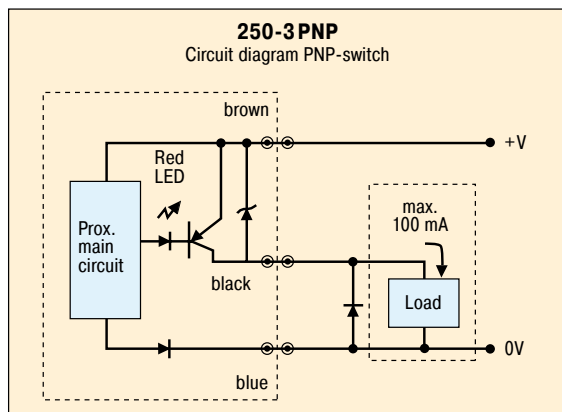

This range of self-compensating shock absorbers is part of the innovative **MAGNUM series** from ACE. You profit from the enhanced product life in the most difficult operating environments provided by the latest seal technology, hardened main bearing and also the integrated positive stop. You achieve **50% more energy absorption capacity** and a much wider range of effective weight capability (**between 3 kg and 63 700 kg!**). This offers you the capability of mounting shock absorbers with the highest energy capacity ratings for their size in the industry and allows full exploitation of your machinery potential. You can access new possibilities in machine design and construction since this range offers such features as a fully threaded outer body and a new clamping flange system.

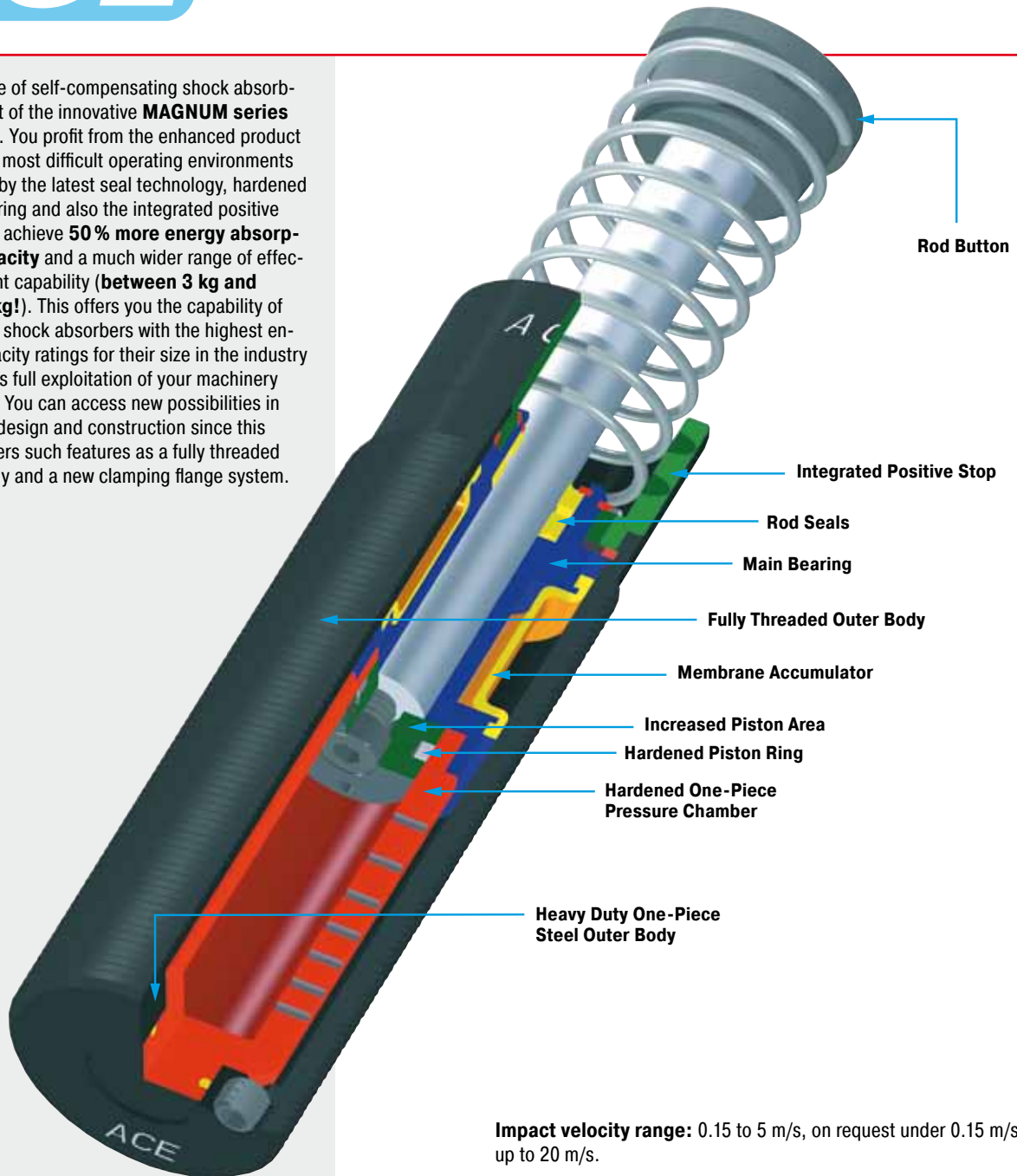

Impact velocity range: 0.15 to 5 m/s, on request under 0.15 m/s and up to 20 m/s.

Operating fluid: Automatic Transmission Fluid (ATF) at 42cSt.

Material: Shock absorber body: Nitride hardened steel. Accessories: Steel with black oxide finish or nitride hardened. Piston rod: Steel hardened and chrome plated. Rod end button: Hardened steel with black oxide finish. Return spring: Zinc plated or plastic-coated. For optimum heat dissipation do not paint shock absorber.

Capacity rating: For emergency use only applications it is sometimes possible to exceed the published max. capacity ratings. Please consult ACE for further details. If your application exceeds the tabulated W_4 figures (max. energy per hour Nm/hr) consider additional cooling. Ask ACE for further details.

Mounting: In any position

Operating temperature range: -12 °C to 70 °C. Higher temperatures see page 53.

On request: Plated finishes. Wearthec finish (seawater resistant), special oils. Mounting inside air cylinders and other special options are available on request.

Noise reduction: 3 to 7 dB when using the impact buttons with urethane insert.



This adjustable shock absorber from ACE is unique. The innovative **MAGNUM series** models provide the next generation of deceleration technology to meet the needs of the future. The latest seal technology, a hardened main bearing and the integrated positive stop provide a significant increase in operating lifetime. Other innovations such as the front and rear adjuster, clamping flanges and the fully threaded outer body provide many new options in installation and mounting. Exploit the advantages of this series in your applications with its **50% increased energy capacity** and a much wider effective weight range. The effective weight range extends from 9 kg up to 80 000 kg. The **MA range** models cover the majority of standard applications, whilst the **ML range** is specially designed for low velocity/high effective weight applications from 300 kg up to 500 000 kg effective weight.

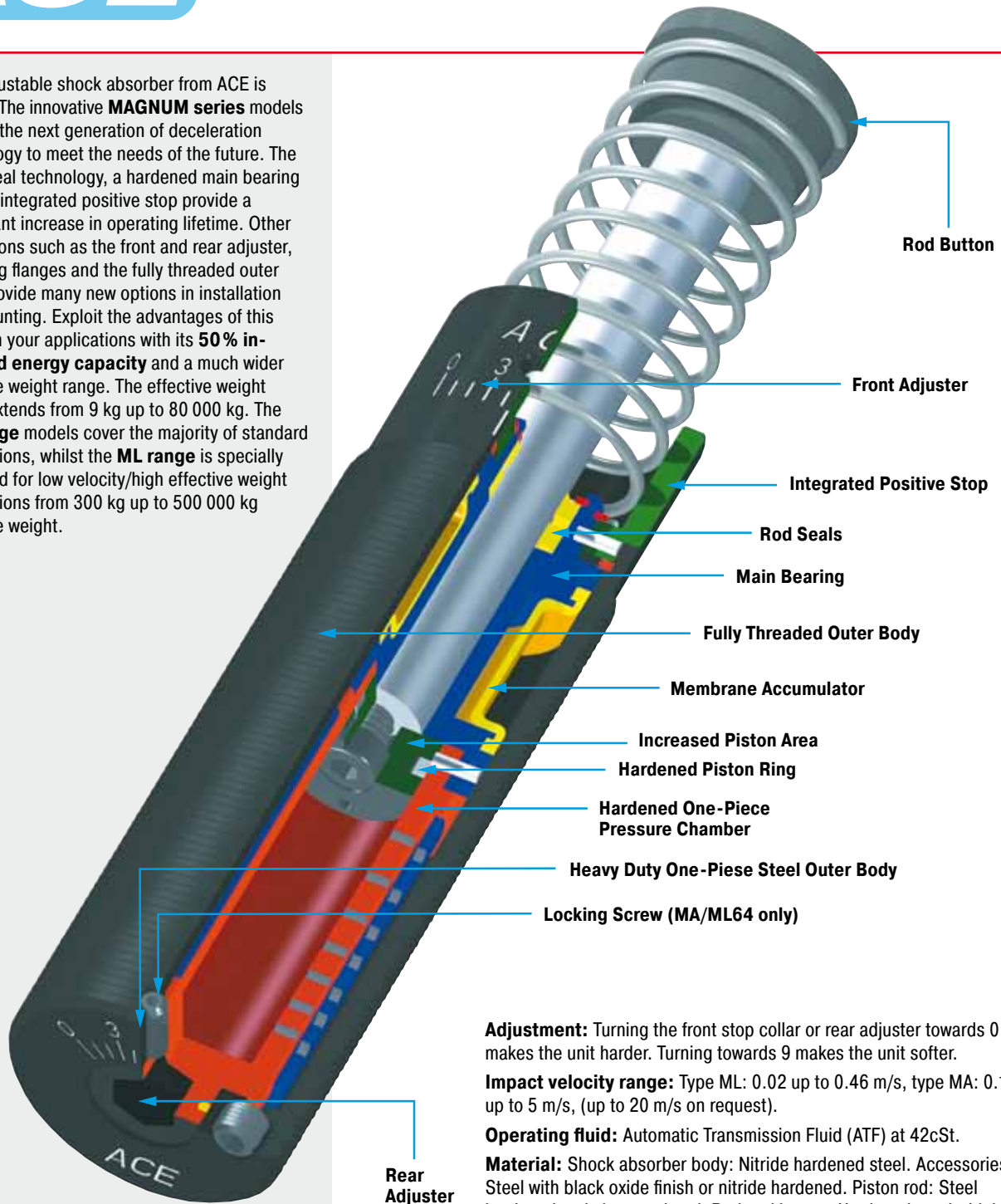

Adjustment: Turning the front stop collar or rear adjuster towards 0 makes the unit harder. Turning towards 9 makes the unit softer.

Impact velocity range: Type ML: 0.02 up to 0.46 m/s, type MA: 0.15 up to 5 m/s, (up to 20 m/s on request).

Operating fluid: Automatic Transmission Fluid (ATF) at 42cSt.

Material: Shock absorber body: Nitride hardened steel. Accessories: Steel with black oxide finish or nitride hardened. Piston rod: Steel hardened and chrome plated. Rod end button: Hardened steel with black oxide finish. Return spring: Zinc plated or plastic-coated. For optimum heat dissipation do not paint shock absorber.

Capacity rating: For emergency use only applications it is sometimes possible to exceed the published max. capacity ratings. Please consult ACE for further details. If your application exceeds the tabulated W_4 figures (max. energy per hour Nm/hr) consider additional cooling. Ask ACE for further details.

Mounting: In any position

Operating temperature range: -12 °C to 70 °C. Higher temperatures see page 53.

On request: Plated finishes. Wearthec finish (seawater resistant), special oils. Mounting inside air cylinders and other special options are available on request.

Noise reduction: 3 to 7 dB when using the impact buttons with urethane insert.



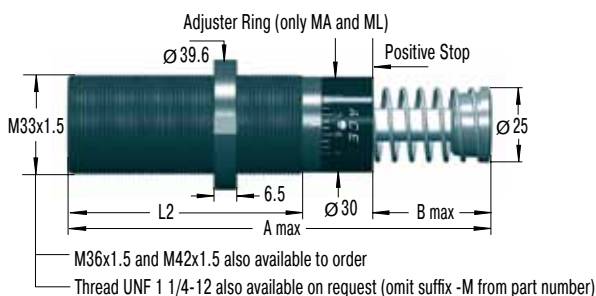

Adjuster (only MA and ML)

S33

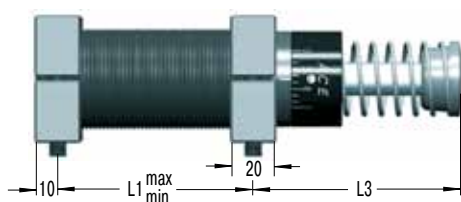

Side Foot Mounting Kit

S33 = 2 flanges + 4 screws M6x40, DIN 912

Because of the thread pitch the fixing holes for the second foot mount should only be drilled and tapped after the first foot mount has been fixed in position.

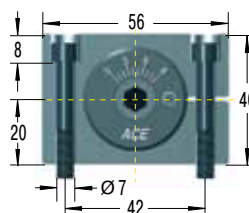

Tightening torque: 11 Nm
Clamping torque: > 90 Nm

C33



Clevis Mounting Kit

C33 = 2 clevis eyes. Delivered assembled to shock absorber. Use positive stop at both ends of travel.

SF33

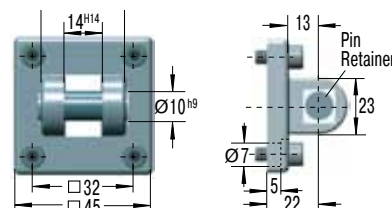

Clevis Flange

SF33 = flange + 4 screws M6x20, DIN 912

Tightening torque: 7.5 Nm

Clamping torque > 50 Nm

Secure with pin or use additional bar. Due to limited force capacity the respective ability should be reviewed by ACE.

Dimensions

Type	¹ Stroke mm	A max	B max	L1 min	L1 max	L2	L3	L5 max	L6 max
MC, MA, ML3325EUM	25	138	23	25	60	83	68	39	168
MC, MA, ML3350EUM	50	189	48.5	32	86	108	93	64	218

¹ Nominal stroke length (without integral stop collar fitted).

Capacity Chart MC33

Type	Max. Energy Capacity				¹ Effective Weight me					Min. Return Force N	Max. Return Force N	Rod Reset Time s	Max. Side Load Angle °	Weight kg
	² W ₃ Nm/Cycle	W ₄ Self-Contained Nm/h	W ₄ with Air/Oil Tank Nm/h	W ₄ with Oil Recirculation Nm/h	Soft		Hard							
					min. kg	max. kg	min. kg	max. kg	min. kg					
MC3325EUM	155	75 000	124 000	169 000	3 - 11	9 - 40	30 - 120	100 - 420	350 - 1 420	45	90	0.03	4	0.45
MC3350EUM	310	85 000	135 000	180 000	5 - 22	18 - 70	60 - 250	210 - 840	710 - 2 830	45	135	0.06	3	0.54

Capacity Chart MA/ML33

Type	Max. Energy Capacity				¹ Effective Weight me		Min. Return Force N	Max. Return Force N	Rod Reset Time s	Max. Side Load Angle °	Weight kg
	² W ₃ Nm/Cycle	W ₄ Self-Contained Nm/h	W ₄ with Air/Oil Tank Nm/h	W ₄ with Oil Recirculation Nm/h	min.	max.					
					kg						
MA3325EUM	170	75 000	124 000	169 000	9	- 1 700	45	90	0.03	4	0.45
ML3325EUM	170	75 000	124 000	169 000	300	- 50 000	45	90	0.03	4	0.45
MA3350EUM	340	85 000	135 000	180 000	13	- 2 500	45	135	0.06	3	0.54
ML3350EUM	340	85 000	135 000	180 000	500	- 80 000	45	135	0.06	3	0.66

¹ The effective weight range limits can be raised or lowered to special order.

² For emergency use only applications it is sometimes possible to exceed the above ratings. Please consult ACE for further details. Specifications relate to the effective stroke length (B max).

M33x1.5

NM33



Locking Ring

PP33

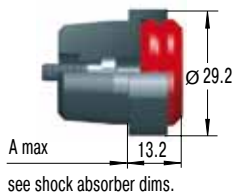

Poly Button

Optional button with elastomer insert for noise suppression. Option supplied ready mounted onto the shock absorber. For self installation see mounting instructions on page 55.

QF33

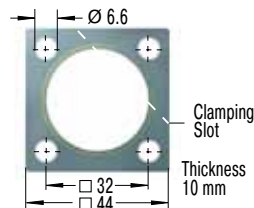

Square Flange

Install with 4 machine screws
Tightening torque: 11 Nm
Clamping torque: > 90 Nm

BV3325

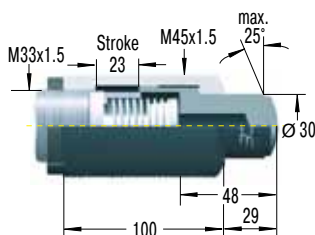

Side Load Adaptor

Mounting, installation etc. see pages 40 to 41 and 52.

BV3350

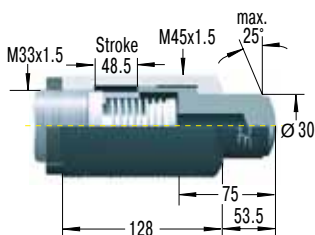

Side Load Adaptor

AS33

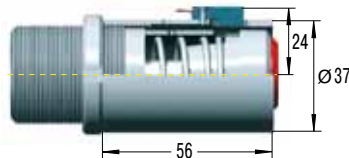

Switch Stop Collar

inc. Proximity Switch and Poly Button with elastomer insert

PB3325

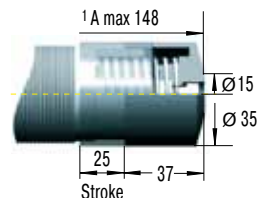

Steel Shroud

Mounting, installation etc. see page 52.

PB3350

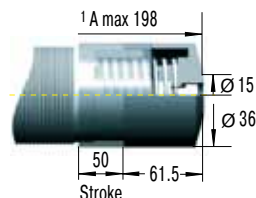

Steel Shroud

¹ Total installation length of the shock absorber inc. steel shroud

Ordering Example

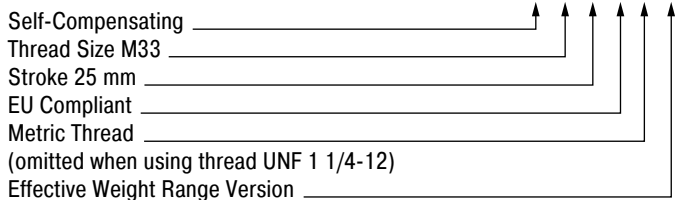

Model Type Prefix

Standard Models

Self-Contained with Return Spring

- MC Self-Compensating
- MA Adjustable
- ML Adjustable, for lower impact velocity

Special Models

Air/Oil Return without Return Spring

- MCA, MAA, MLA

Air/Oil Return with Return Spring

- MCS, MAS, MLS

Self-Contained without Return Spring

- MCN, MAN, MLN

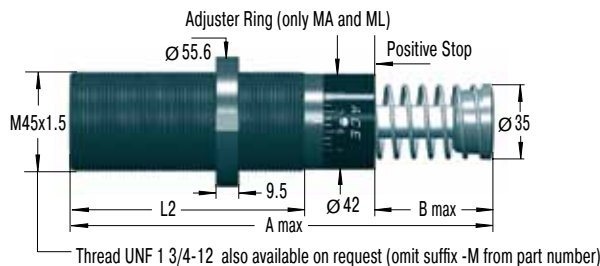

Adjuster (only MA and ML)

S45

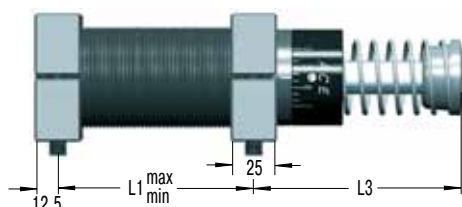

Side Foot Mounting Kit

S45 = 2 flanges + 4 screws M8x50, DIN 912

Because of the thread pitch the fixing holes for the second foot mount should only be drilled and tapped after the first foot mount has been fixed in position.

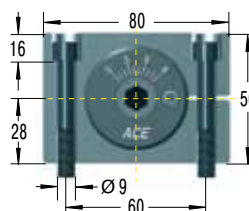

Tightening torque: 27 Nm
 Clamping torque: > 350 Nm

C45

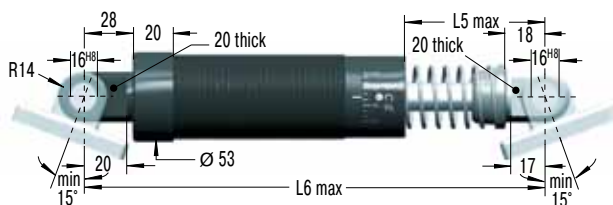

Clevis Mounting Kit

C45 = 2 clevis eyes. Delivered assembled to shock absorber. Use positive stop at both ends of travel.

SF45

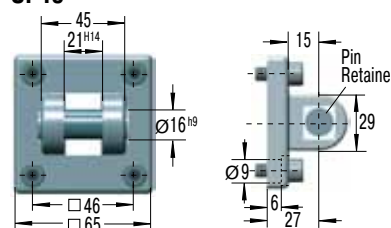

Clevis Flange

SF45 = flange + 4 screws M8x20, DIN 912

Tightening torque: 7.5 Nm
 Clamping torque: > 140 Nm

Secure with pin or use additional bar.
Due to limited force capacity the respective ability should be reviewed by ACE.

Dimensions

Type	¹ Stroke mm	A max	B max	L1 min	L1 max	L2	L3	L5 max	L6 max
MC, MA, ML4525EUM	25	145	23	32	66	95	66	43	200
MC, MA, ML4550EUM	50	195	48.5	40	92	120	91	68	250
MC, MA4575EUM	75	246	74	50	118	145	116	93	301

¹ Nominal stroke length (without integral stop collar fitted).

Capacity Chart MC45

Type Self-Compensating	Max. Energy Capacity				¹ Effective Weight me					Min. Return Force N	Max. Return Force N	Rod Reset Time s	Max. Side Load Angle °	Weight kg
	² W ₃ Nm/Cycle	W ₄ Self-Contained Nm/h	W ₄ with Air/Oil Tank Nm/h	W ₄ with Oil Recirculation Nm/h	Soft		Hard							
					-0 min. max. kg	-1 min. max. kg	-2 min. max. kg	-3 min. max. kg	-4 min. max. kg					
MC4525EUM	340	107 000	158 000	192 000	7 - 27	20 - 90	80 - 310	260 - 1 050	890 - 3 540	70	100	0.03	4	1.13
MC4550EUM	680	112 000	192 000	248 000	13 - 54	45 - 180	150 - 620	520 - 2 090	1 800 - 7 100	70	145	0.08	3	1.36
MC4575EUM	1020	146 000	225 000	282 000	20 - 80	70 - 270	230 - 930	790 - 3 140	2 650 - 10 600	50	180	0.11	2	1.59

Capacity Chart MA/ML45

Type Adjustable	Max. Energy Capacity				¹ Effective Weight me		Min. Return Force N	Max. Return Force N	Rod Reset Time s	Max. Side Load Angle °	Weight kg
	² W ₃ Nm/Cycle	W ₄ Self-Contained Nm/h	W ₄ with Air/Oil Tank Nm/h	W ₄ with Oil Recirculation Nm/h	min. kg	max. kg					
MA4525EUM	390	107 000	158 000	192 000	40	- 10 000	70	100	0.03	4	1.14
ML4525EUM	390	107 000	158 000	192 000	3 000	- 110 000	70	100	0.03	4	1.13
MA4550EUM	780	112 000	192 000	248 000	70	- 14 500	70	145	0.08	3	1.36
ML4550EUM	780	112 000	192 000	248 000	5 000	- 180 000	70	145	0.08	3	1.36
MA4575EUM	1 170	146 000	225 000	282 000	70	- 15 000	50	180	0.11	2	1.59

¹ The effective weight range limits can be raised or lowered to special order.

² For emergency use only applications it is sometimes possible to exceed the above ratings. Please consult ACE for further details. Specifications relate to the effective stroke length (B max).

M45x1.5

NM45



Locking Ring

PP45

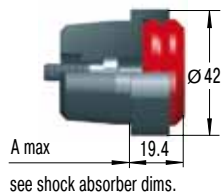

see shock absorber dims.

Poly Button

Optional button with elastomer insert for noise suppression. Option supplied ready mounted onto the shock absorber. For self installation see mounting instructions on page 55.

QF45

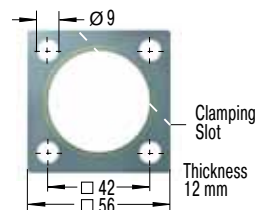

Square Flange

Install with 4 machine screws
Tightening torque: 27 Nm
Clamping torque: > 200 Nm

BV4525

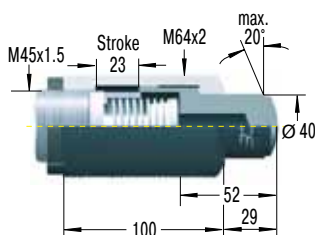

Side Load Adaptor

Mounting, installation etc. see pages 40 to 41 and 52.

BV4550

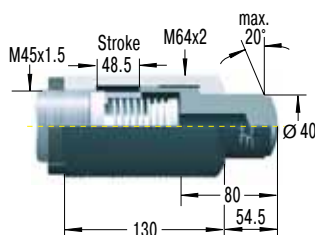

Side Load Adaptor

AS45

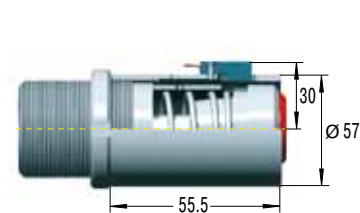

Switch Stop Collar

inc. Proximity Switch and Poly Button with elastomer insert

PB4525

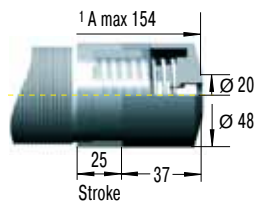

Steel Shroud

Mounting, installation etc. see page 52.

PB4550

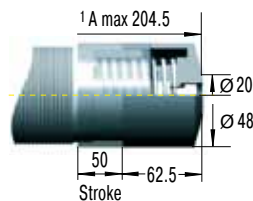

Steel Shroud

¹ Total installation length of the shock absorber inc. steel shroud

Ordering Example

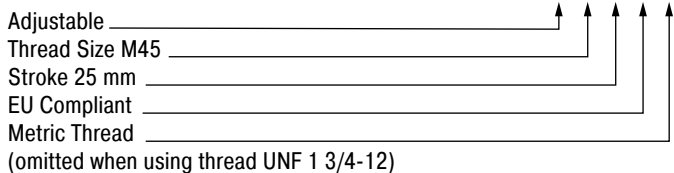

ML4525EUM

Model Type Prefix

Standard Models

Self-Contained with Return Spring

- MC Self-Compensating
- MA Adjustable
- ML Adjustable, for lower impact velocity

Special Models

Air/Oil Return without Return Spring

MCA, MAA, MLA

Air/Oil Return with Return Spring

MCS, MAS, MLS

Self-Contained without Return Spring

MCN, MAN, MLN

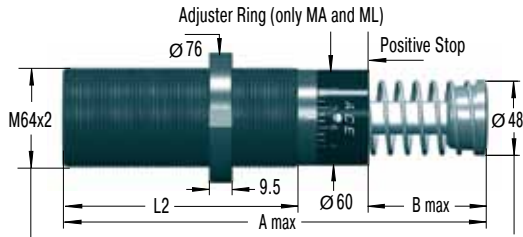

Thread UNF 2 1/2-12 also available on request (omit suffix -M from part number)

Note: 150 mm stroke model does not include stop collar and positive stop is provided by the rod button (Ø 60 mm)



Adjuster (only MA and ML)

S64

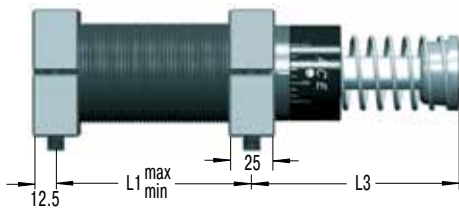

Side Foot Mounting Kit

S64 = 2 flanges + 4 screws M10x80, DIN 912

Because of the thread pitch the fixing holes for the second foot mount should only be drilled and tapped after the first foot mount has been fixed in position.

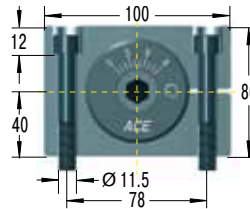

Tightening torque: 50 Nm
Clamping torque: > 350 Nm

C64



Clevis Mounting Kit

C64 = 2 clevis eyes. Delivered assembled to shock absorber.

¹ with 150 mm stroke Dia. 60 mm. Order C64/150.

Use positive stop at both ends of travel.

SF64

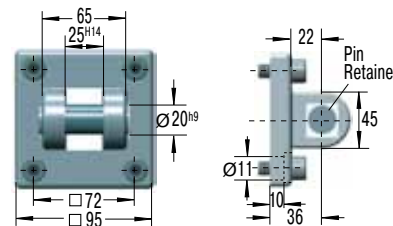

Clevis Flange

SF64 = flange + 4 screws M10x20, DIN 912

Tightening torque: 15 Nm

Clamping torque: > 200 Nm

Secure with pin or use additional bar. Due to limited force capacity the respective ability should be reviewed by ACE.

Dimensions

Type	¹ Stroke mm	A max	B max	L1 min	L1 max	L2	L3	L5 max	L6 max
ML6425EUM	25	174	23	40	86	114	75.5	60	260
MC, MA, ML6450EUM	50	225	48.5	50	112	140	100	85	310
MC, MA64100EUM	100	326	99.5	64	162	191	152	136	410
MC, MA64150EUM	150	450	150	80	212	241	226	187	530

¹ Nominal stroke length (without integral stop collar fitted).

Capacity Chart MC64

Type Self-Compensating	Max. Energy Capacity				¹ Effective Weight me					Min. Return Force N	Max. Return Force N	Rod Reset Time s	Max. Side Load Angle °	Weight kg
	² W ₃ Nm/Cycle	W ₄ Self-Contained Nm/h	W ₄ with Air/Oil Tank Nm/h	W ₄ with Oil Recirculation Nm/h	Soft		Hard							
					-0 min. max. kg	-1 min. max. kg	-2 min. max. kg	-3 min. max. kg	-4 min. max. kg					
MC6450EUM	1 700	146 000	293 000	384 000	35 - 140	140 - 540	460 - 1 850	1 600 - 6 300	5 300 - 21 200	90	155	0.12	4	2.9
MC64100EUM	3 400	192 000	384 000	497 000	70 - 280	270 - 1 100	930 - 3 700	3 150 - 12 600	10 600 - 42 500	105	270	0.34	3	3.7
MC64150EUM	5 100	248 000	497 000	644 000	100 - 460	410 - 1 640	1 390 - 5 600	4 700 - 18 800	16 000 - 63 700	75	365	0.48	2	5.1

Capacity Chart MA/ML64

Type Adjustable	Max. Energy Capacity				¹ Effective Weight me		Min. Return Force N	Max. Return Force N	Rod Reset Time s	Max. Side Load Angle °	Weight kg
	² W ₃ Nm/Cycle	W ₄ Self-Contained Nm/h	W ₄ with Air/Oil Tank Nm/h	W ₄ with Oil Recirculation Nm/h	min.	max.					
ML6425EUM	1 020	124 000	248 000	332 000	7 000	- 300 000	120	155	0.06	5	2.5
MA6450EUM	2 040	146 000	293 000	384 000	220	- 50 000	90	155	0.12	4	2.9
ML6450EUM	2 040	146 000	293 000	384 000	11 000	- 500 000	90	155	0.12	4	2.9
MA64100EUM	4 080	192 000	384 000	497 000	270	- 52 000	105	270	0.34	3	3.7
MA64150EUM	6 120	248 000	497 000	644 000	330	- 80 000	75	365	0.48	2	5.1

¹ The effective weight range limits can be raised or lowered to special order.

² For emergency use only applications it is sometimes possible to exceed the above ratings. Please consult ACE for further details. Specifications relate to the effective stroke length (B max).

M64x2

NM64

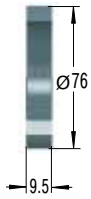

Locking Ring

PP64

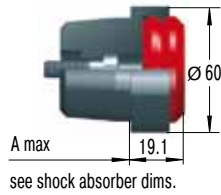

Poly Button

Optional button with elastomer insert for noise suppression. Option supplied ready mounted onto the shock absorber. For self installation see mounting instructions on page 55.

QF64

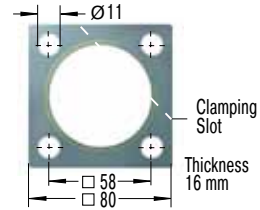

Square Flange

Install with 4 machine screws
Tightening torque: 50 Nm
Clamping torque: > 210 Nm

BV6425

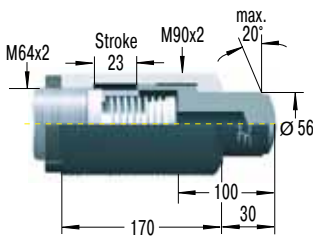

Side Load Adaptor

BV6450

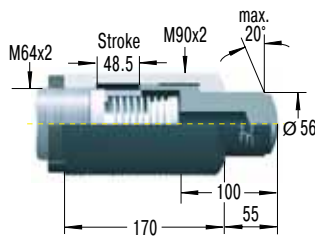

Side Load Adaptor

QF90

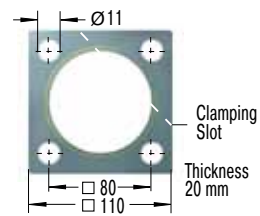

Square Flange

Install with 4 machine screws
Tightening torque: 50 Nm
Clamping torque: > 210 Nm

Mounting, installation etc. see pages 40 and 52.

PB6425

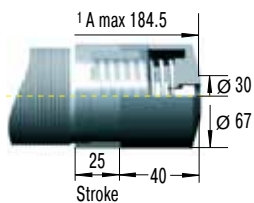

Steel Shroud

PB6450

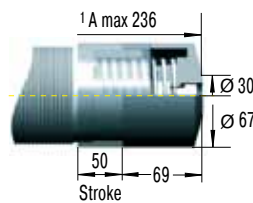

Steel Shroud

¹ Total installation length of the shock absorber inc. steel shroud

Mounting, installation etc. see page 52.

Ordering Example

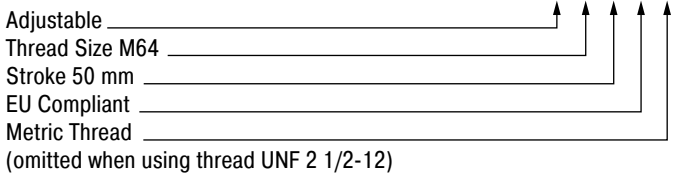

MA6450EUM

Model Type Prefix

Standard Models

Self-Contained with Return Spring

- MC Self-Compensating
- MA Adjustable
- ML Adjustable, for lower impact velocity

Special Models

Air/Oil Return without Return Spring

MCA, MAA, MLA

Air/Oil Return with Return Spring

MCS, MAS, MLS

Self-Contained without Return Spring

MCN, MAN, MLN

Based on the successful damping technology of our MAGNUM-Series, ACE offers this self-adjusting industrial shock absorber in complete **stainless steel design**. All outer parts, such as outer body, stop collar, and main bearing are manufactured of **V4A (material spec. number 1.4404)**. The MAGNUM VA series is therefore ideally suited for applications within the fields of medical technology, the food industry, electronics and the marine and associated industries. The **MAGNUM VA series** offers all the proven advantages of the MAGNUM standard series, like its robust and most modern seal technology, the highest energy absorption in a compact design, an integrated mechanical stop, and a wide range of effective weights. This series is available in thread sizes M33x1.5 to M64x2 with stroke lengths of up to 100 mm. The MAGNUM VA series also offers a rod button made of V4A with a polyurethane element to reduce noise levels. Additionally all MAGNUM VA dampers are filled with a special oil that conforms to the approval requirements (NSF-H1) of the food industry ex stock.

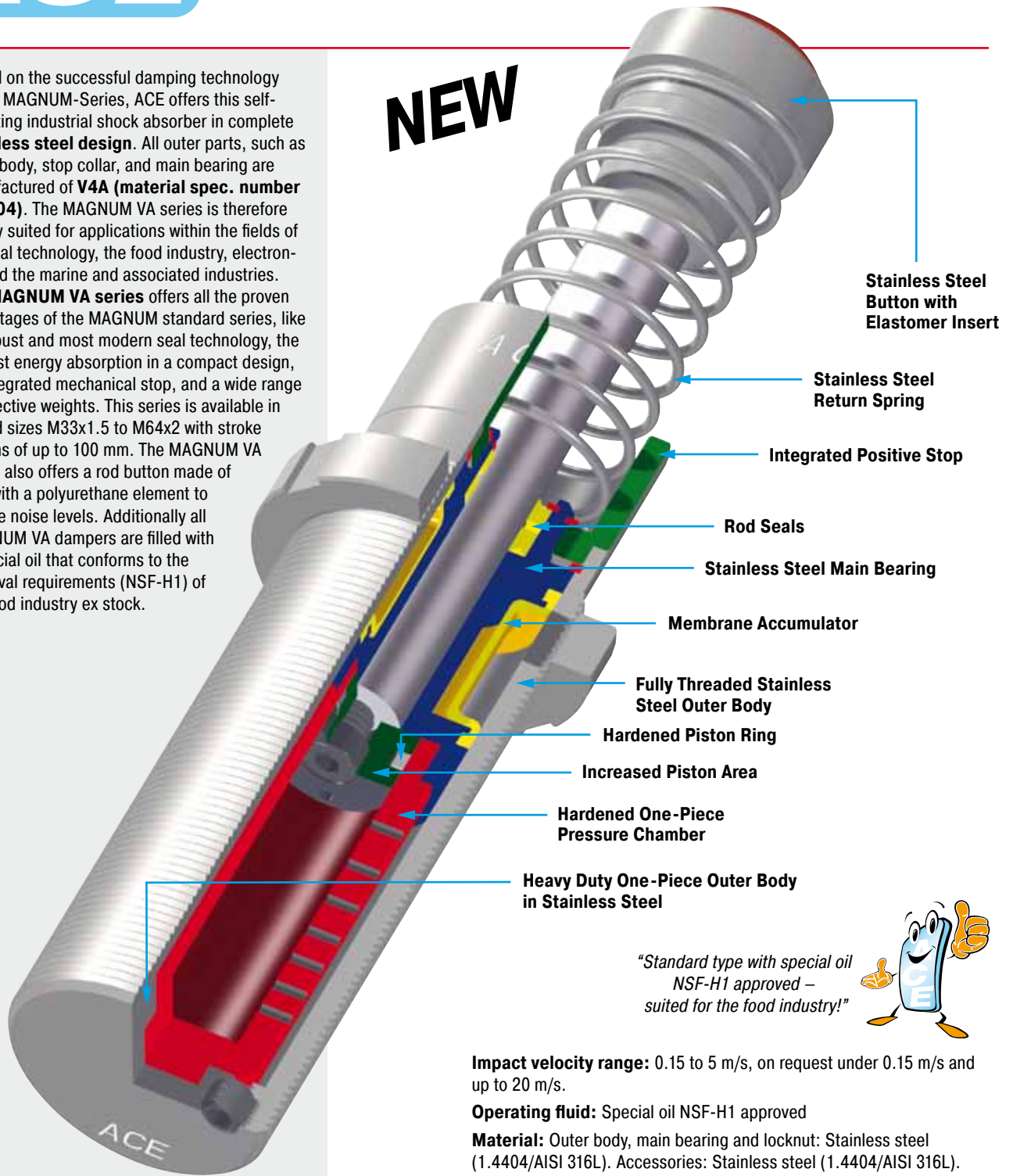

Impact velocity range: 0.15 to 5 m/s, on request under 0.15 m/s and up to 20 m/s.

Operating fluid: Special oil NSF-H1 approved

Material: Outer body, main bearing and locknut: Stainless steel (1.4404/AISI 316L). Accessories: Stainless steel (1.4404/AISI 316L). Piston rod: hardened and chrome plated stainless steel. Button: Stainless steel (1.4404/AISI 316L) with elastomer insert. Return spring: Stainless steel.

Capacity rating: For emergency only applications it is sometimes possible to exceed the published max. capacity ratings. Please consult ACE for further details. If your application exceeds the tabulated W_4 figures (max. energy per hour Nm/hr) consider additional cooling. Ask ACE for further details.

Mounting: In any position

Operating temperature range: -12°C to 70°C. For higher temperatures consult ACE.

On request: special oils, viton seals and special accessories

Noise reduction: 3 to 7 dB when using the impact buttons with urethane insert.



NEW

MC33xxEUM-V4A



NM33-V4A

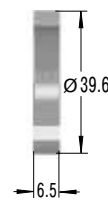

Locking Ring

QF33-V4A

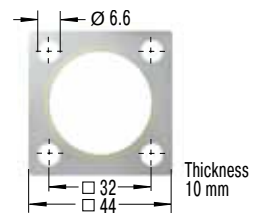

Square Flange

MC45xxEUM-V4A

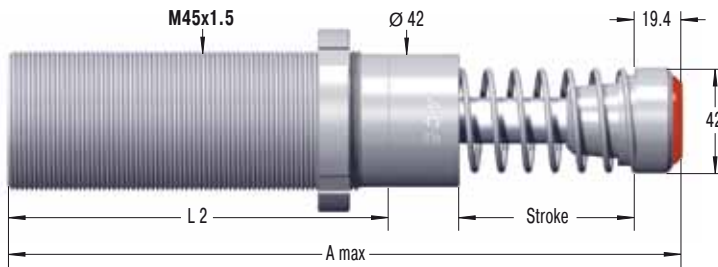

NM45-V4A

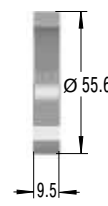

Locking Ring

QF45-V4A

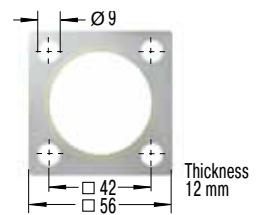

Square Flange

MC64xxEUM-V4A

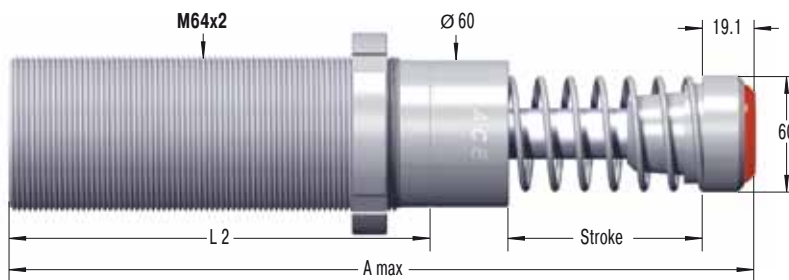

NM64-V4A

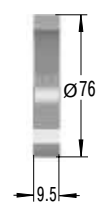

Locking Ring

QF64-V4A

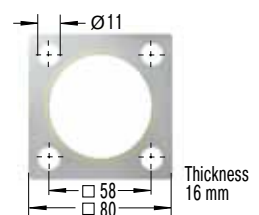

Square Flange

Dimensions

Type	Stroke mm	A max	L2
MC3325EUM-V4A	23	151.2	83
MC3350EUM-V4A	48.5	202.2	108
MC4525EUM-V4A	23	164.5	95
MC4550EUM-V4A	48.5	214.4	120
MC4575EUM-V4A	74	265.4	145
MC6450EUM-V4A	48.5	244.1	140
MC64100EUM-V4A	99.5	345.1	191

Ordering Example

Self-Compensating MC4550EUM-1-V4A
 Thread Size M45
 Stroke 50 mm
 EU Compliant
 Metric Thread
 Effective Weight Range Version
 Stainless Steel 1.4404/AISI 316L

Capacity Chart MC33/MC45/MC64

Type	Max. Energy Capacity		1 Effective Weight me					Min. Return Force N	Max. Return Force N	Rod Reset Time s	Max. Side Load Angle °	Weight kg
	2 W ₃ Nm/Cycle	W ₄ Nm/h	Soft				Hard					
			-0 min. max. kg	-1 min. max. kg	-2 min. max. kg	-3 min. max. kg	-4 min. max. kg					
MC3325EUM-V4A	155	75 000	3 - 11	9 - 40	30 - 120	100 - 420	350 - 1 420	45	90	0.03	4	0.45
MC3350EUM-V4A	310	85 000	5 - 22	18 - 70	60 - 250	240 - 840	710 - 2 830	45	135	0.06	3	0.54
MC4525EUM-V4A	340	107 000	7 - 27	20 - 90	80 - 310	260 - 1 050	890 - 3 540	70	100	0.03	4	1.13
MC4550EUM-V4A	680	112 000	13 - 54	45 - 180	150 - 620	520 - 2 090	1 800 - 7 100	70	145	0.08	3	1.36
MC4575EUM-V4A	1 020	146 000	20 - 80	70 - 270	230 - 930	790 - 3 140	2 650 - 10 600	50	180	0.11	2	1.59
MC6450EUM-V4A	1 700	146 000	35 - 140	140 - 540	460 - 1 850	1 600 - 6 300	5 300 - 21 200	90	155	0.12	4	2.9
MC64100EUM-V4A	3 400	192 000	70 - 280	270 - 1 100	930 - 3 700	3 150 - 12 600	10 600 - 42 500	105	270	0.34	3	3.7

¹ The effective weight range limits can be raised or lowered to special order.

² For emergency only applications it is sometimes possible to exceed the above ratings. Please consult ACE for further details.

BV Side Load Adaptor

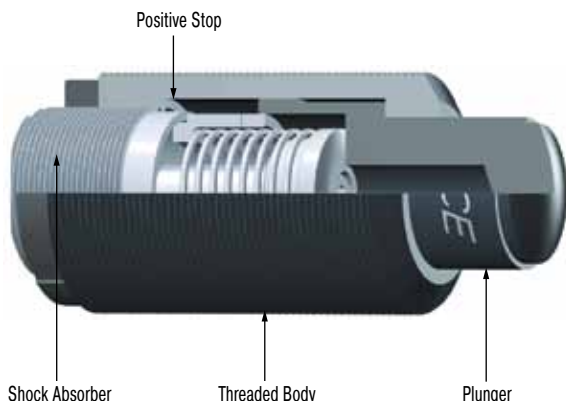

For side load impact angles from 3° to 25°

With side load impact angles of more than 3° the operation lifetime of the shock absorber reduces rapidly due to increased wear of rod bearings. The optional BV side load adaptor provides long lasting solution.

BV3325 (M45x1.5) for MC, MA, ML3325EUM (M33x1.5)

BV3350 (M45x1.5) for MC, MA, ML3350EUM (M33x1.5)

BV4525 (M64x2) for MC, MA, ML4525EUM (M45x1.5)

BV4550 (M64x2) for MC, MA, ML4550EUM (M45x1.5)

BV6425 (M90x2) for ML6425EUM (M64x2)

BV6450 (M90x2) for MC, MA, ML6450EUM (M64x2)

Material: Threaded body and plunger: Hardened high tensile steel. Hardened 610 HV1.

Mounting: Directly mount the shock absorber/side mount assembly on the outside thread of the side load adaptor or by using the QF flange. You cannot use a foot mount.

Calculation example and installation hints see page 40.

PB Steel Shroud

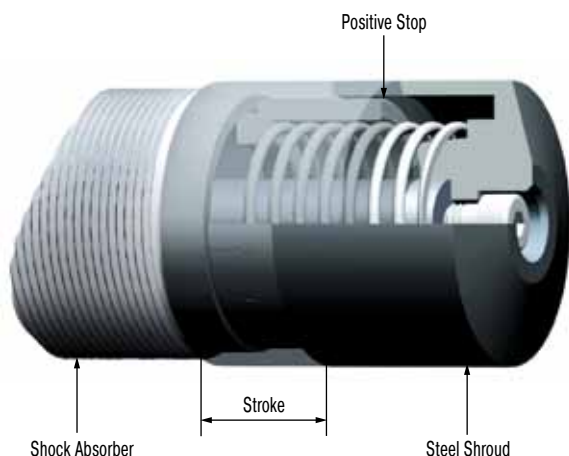

For thread sizes M33x1.5, M45x1.5 and M64x2 with 25 or 50 mm stroke

Grinding beads, sand, welding splatter, paints and adhesives etc. can adhere to the piston rod. They then damage the rod seals and the shock absorber quickly fails. In many cases the installation of the optional steel shroud can provide worthwhile protection and increase lifetime.

Material: Hardened high tensile steel.

Mounting: To mount the PB steel shroud it is necessary to remove the rod end button of the shock absorber.

Note! When installing don't forget to allow operating space for the shroud to move as the shock absorber is cycled.

AS Switch Stop Collar

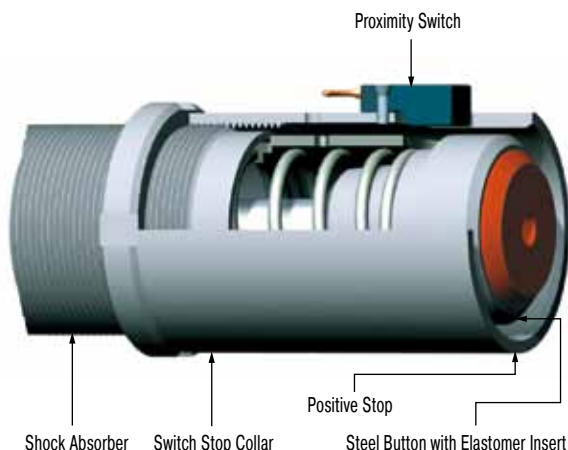

For thread sizes M33x1.5 and M45x1.5

The ACE stop light switch stop collar combination serves as a safety element to provide stroke position information for automatically sequenced machines. The compact construction allows its use in nearly any application. The standard rod button is detected by the proximity switch at the end of its stroke to provide switch actuation. The switch is normally open when the shock absorber is extended and only closes when it has completed its operating stroke. The AS switch stop collar combination is only delivered ready mounted onto the shock absorber c/w the switch.

Material: Hardened high tensile steel.

For circuit diagram of proximity switch see page 41.

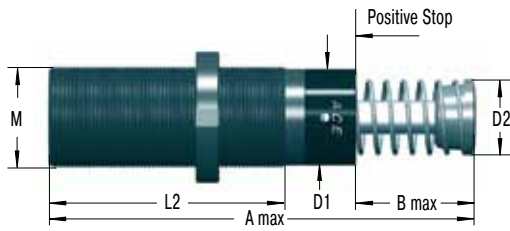

Dimensions and Capacity Chart

Type Part Number	1 Stroke mm	A max	B	D1	D2	L2	2 M	Max. Energy Capacity			Max. Side Load Angle °	Weight kg
								per Cycle W ₃ max. Nm	per Hour			
									at 20 °C W ₄ max. Nm	at 100 °C W ₄ max. Nm		
MC3325EUM	25	138	23.0	30	25	83	M33x1.5	155	215 000	82 000	4	0.45
MC3350EUM	50	189	48.5	30	25	108	M33x1.5	310	244 000	93 000	3	0.54
MC4525EUM	25	145	23.0	42	35	95	M45x1.5	340	307 000	117 000	4	1.13
MC4550EUM	50	195	48.5	42	35	120	M45x1.5	680	321 000	122 000	3	1.36
MC6450EUM	50	225	48.5	60	48	140	M64x2	1 700	419 000	159 000	4	2.90
MC64100EUM	100	326	99.5	60	48	191	M64x2	3 400	550 000	200 000	3	3.70

1 Nominal stroke length (without stop collar fitted).
2 UNF threads available on request.

The calculation and selection of the most suitable shock absorber (effective weight range) for your application should be carried out or checked by ACE Controls. Adjustable models are also available on request.

Ordering Example

Self-Compensating _____ ↑
 Thread Size M33 _____ ↑
 Stroke 50 mm _____ ↑
 EU Compliant _____ ↑
 Metric Thread (omitted when using thread UNF) _____ ↑
 Effective Weight Range Code _____ ↑
 Version for High Temperature Use _____ ↑

MC3350EUM-2-HT

Details Required when Ordering

Load to be decelerated m (kg)
 Impact velocity v (m/s)
 Propelling force F (N)
 Operating cycles per hour x (/hr)
 Number of absorbers in parallel n
 Ambient temperature °C

Technical Data

Impact velocity range: 0.15 to 5 m/s, up to 20 m/s on request.

Operating fluid: Special temperature stable synthetic oil

Material: Shock absorber body: Nitride hardened steel. Accessories: Steel with black oxide finish or nitride hardened. Piston rod: Steel hardened and chrome plated. Rod end button: Hardened steel with black oxide finish. Return spring: Zinc plated or plastic-coated. For optimum heat dissipation do not paint shock absorber.

Mounting: In any position

Operating temperature range: -20 °C to 150 °C

Capacity rating: For emergency applications it is sometimes possible to exceed above max. capacity ratings (please consult ACE for details). The above W₄ ratings (max. energy Nm per hour) can sometimes be increased by using an external air/oil tank (see page 54) and model version prefix **MCA** (please consult ACE for further details).

On request: Plated finishes for additional corrosion protection.



A01

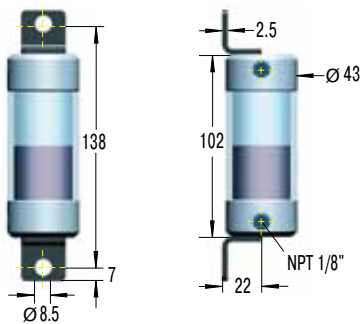

Oil capacity 20 cm³
Material: Alu. caps and polycarbonate body.

1 A03



Oil capacity 370 cm³
Material: Steel

1 A0691

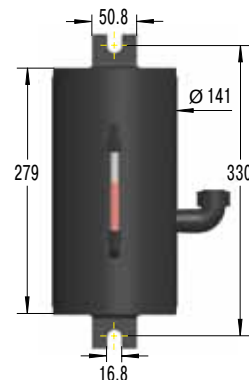

Oil capacity 2600 cm³
Material: Steel

¹ Detail drawings on request

Max. pressure 8 bar. Max. temperature 80 °C.

Oil filling: ATF-Oil 42 cSt at 40 °C for all shock absorbers in MAGNUM Series. Mount air/oil tank higher than shock absorber. Bleed all air from system before operating.

Attention: Exhaust tank before carrying out service. Check valve holds pressure!

Suggested air/oil tanks in accordance with W₄ ratings

Part Numbers

Type	With Tank Examples 1-4		With Recirc. Circuits Ex. 5-6		Conn. Pipe. Ø Min.
	Tank	Non-Return Valve	Tank	Non-Return Valve	
MCA, MAA, MLA33...	A01	CV1/8	A03	CV1/4	4
MCA, MAA, MLA45...	A01	CV1/8	A03	CV3/8	6
MCA, MAA, MLA64...	A03	CV1/4	A0691	CV1/2	8
CAA, AA2...	A0691	CV1/2	A082	CV3/4	15
CAA, AA3...	A0691	CV1/2	A082	CV3/4	19
CAA4...	A082	CV3/4	A082	CV3/4	38

A082 details on request

Connection Examples Air/Oil Tanks

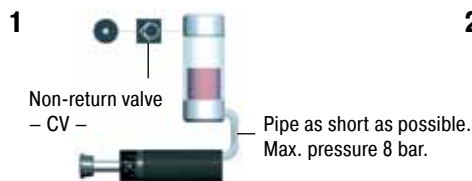

Piston rod returns immediately to extended position when load moves away. Operation without main air supply possible for short periods.



Return stroke may be sequenced by pneumatic valve at any desired time. No return force until valve energised.

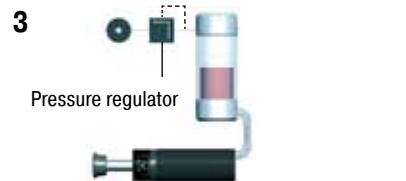

Return force can be adjusted by pressure regulator. Ensure safe minimum pressure to return shock absorber.



Spring return with air/oil tank. No air supply connected. Note: Will extend return time.

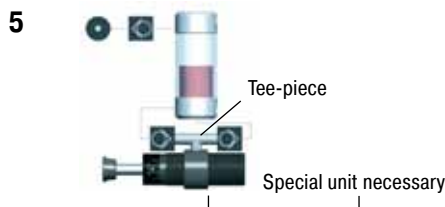

Oil recirculation circuit for extreme high cycle rates. Warm oil is positively circulated through air/oil tank for increased heat dissipation.

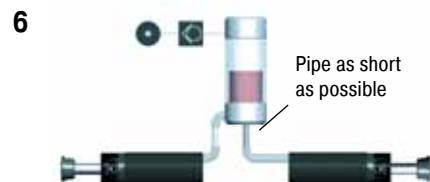

Connection of two shock absorbers to one air/oil tank is possible. Use next larger size tank. Combination with examples 2, 3 and 5 possible.

Thread Sizes for connection to air/oil tank

Type	Thread Bottom	² Thread Side
MCA, MAA, MLA33	¹ G1/8 inside	G1/8 inside
MCA, MAA, MLA45	G1/8 inside	G1/8 inside
MCA, MAA, MLA64	G1/4 inside	G1/4 inside

¹ adapted
² on request (add suffix -PG/-P)

Part Numbers: CV...

Max. pressure: 20 bar
Max. temperature: 95 °C
Suitable for: Oil, air, water.
Material: Aluminium

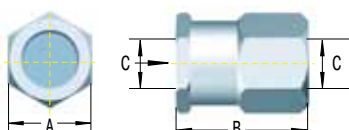

Non-Return Valves

Type	A	B	C
CV1/8	19	24	1/8-27 NPT
CV1/4	29	33	1/4-18 NPT
CV3/8	29	33	3/8-18 NPT
CV1/2	41	40	1/2-14 NPT
CV3/4	48	59	3/4-14 NPT

Issue 6.2011 Specifications subject to change

Mechanical Stop

The MAGNUM series units have a built in stop collar (mechanical stop) which also serves as the front adjuster.

If using a shock absorber without a stop collar it is important to install a mechanical stop 0.5 to 1mm before the end of the stroke.



General

For optimum heat dissipation do not paint the shock absorber. For applications in environments with acids, dusts or powders, abrasives, steam or water please protect the shock absorber and/or consider the special accessories on page 52. The shock absorber should be securely mounted onto a flat and smooth surface of adequate strength.

Self-Compensating Models

The MC family of shock absorbers are self-compensating. Providing the effective weight on the application remains within the band given in the capacity charts then no adjustment is necessary for changes in weights, speeds or propelling force. These units are available with five standard operating bands (me min. – me max.) and are identified by the suffix number after the model which goes from -0 (very soft) up to -4 (very hard). The optimum deceleration is achieved when there is no abrupt change in the load velocity at the beginning or the end of the shock absorber stroke.

If there is a hard impact at the start of stroke:
 → use the next softer version (i. e. lower suffix number)

If there is a hard setdown at the end of stroke:
 → use the next harder version, or mount two units in parallel.

Alternatively change to a larger bore size unit. Contact ACE for further advice.

Adjustable Models

The adjustment has a graduated scale from 0 to 9. The adjuster in the body of MA/ML64 has a side mounted locking screw which should be loosened (1/2 turn max.) with a hex. key before commencing adjustment.

The MAGNUM series units can be adjusted by the hex. socket at the rear of the body or by rotating the front stop collar. Both adjusters are internally connected and will show the same adjustment value on the scales as they are turned. After installation cycle the equipment a few times and turn the adjustment until optimum deceleration is achieved (i.e. no abrupt change in the load velocity observed at the beginning or at the end of shock absorber stroke). The shock absorber is delivered set at 5.

If there is a hard impact at start of stroke:
 → adjust the unit softer i. e. towards 9 on the scale

If there is a hard setdown at end of stroke:
 → adjust the unit harder i. e. towards 0.

Adjustment approaching "0" means:

- a) Impact velocity is too low:
 → consider changing to Model type ML or:
- b) Shock absorber selected is too small:
 → use next larger size or mount 2 units in parallel.

Mounting Options

Basic Model



Flange Mounting



Side Foot Mounting



Clevis Mounting



Removing Rod End Button

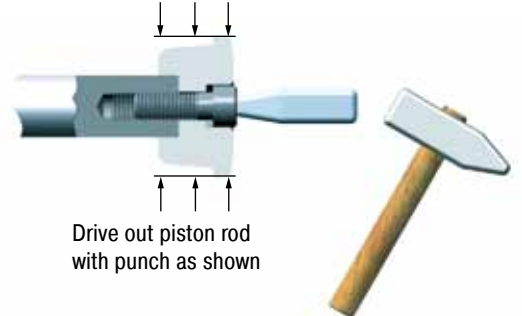
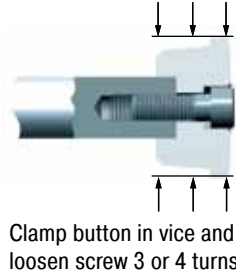
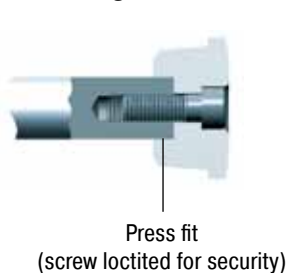

Repairs

It is possible to overhaul ACE shock absorbers in M33 sizes and larger. We would recommend that damaged or worn shock absorbers are returned to ACE for repair. You will find that this is more economic than

the comparative cost of repairing yourself. Spare parts and seal kits etc. are available however if required.

The **CA2 to CA4** complete the ACE product range of self-compensating shock absorbers. With these units ACE has a continuous range of self-compensating units to handle **effective weights from 0.3 kg up to 326 000 kg**. The robust CA series units are designed for really heavy duty applications. Damage caused by errors in adjustment setting is ruled out by their self-compensating design. You can select the correct model for your application using the ACE Selection Program or by using the capacity chart. The CA units are maintenance-free and self-contained with an energy capacity of up to 126 500 Nm.

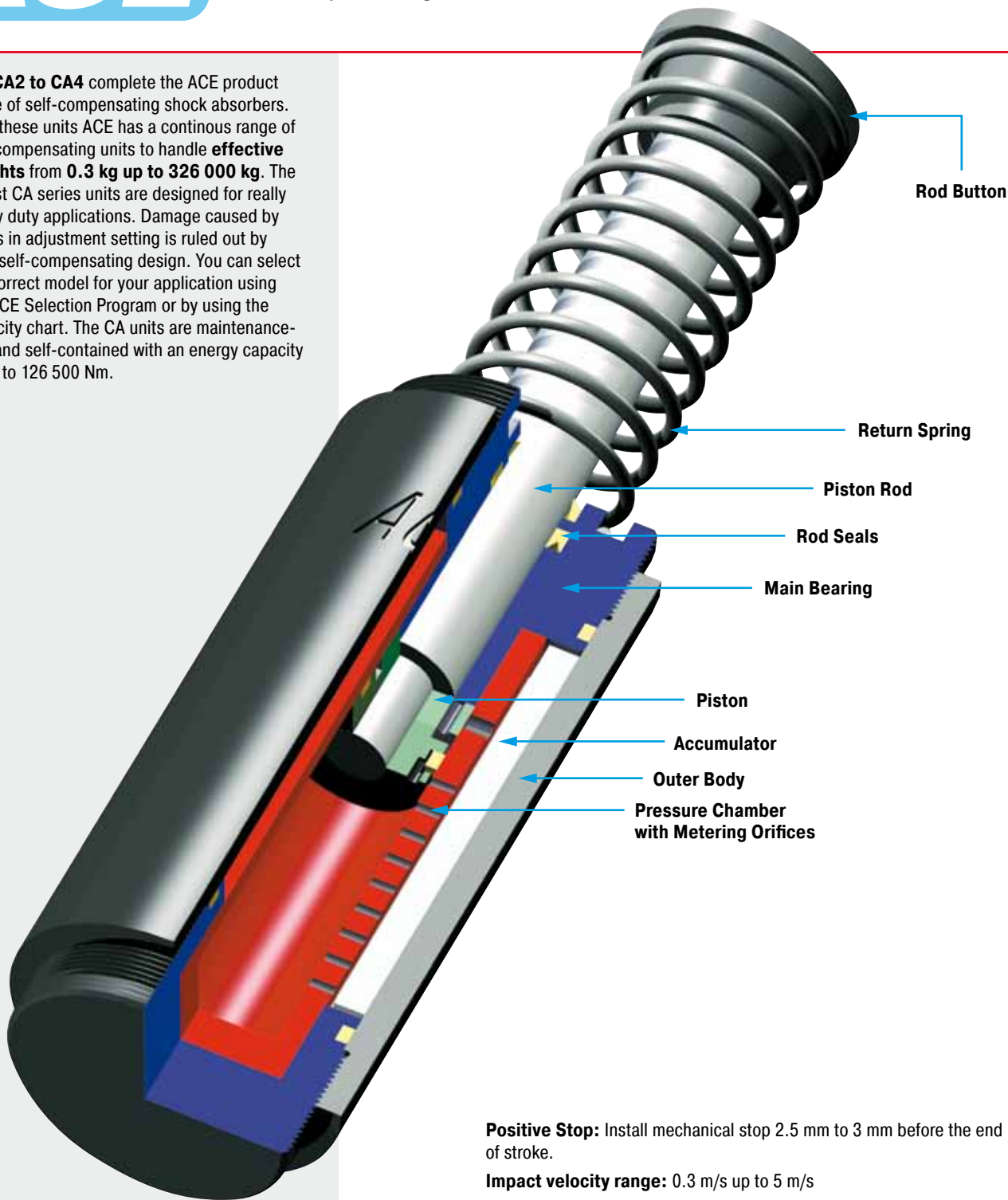

Positive Stop: Install mechanical stop 2.5 mm to 3 mm before the end of stroke.

Impact velocity range: 0.3 m/s up to 5 m/s

Operating fluid: Automatic Transmission Fluid (ATF) viscosity 42 cSt. at 40 °C

Material: Body and accessories: Steel with black oxide finish. Piston rod: Steel hardened and chrome plated. Rod end button: Steel hardened with black oxide finish. Return spring: Zinc plated. For optimum heat dissipation do not paint outer body.

Capacity rating: For emergency use only applications it may be possible to exceed published energy per cycle (W_3) figures. Please consult ACE for further details.

Mounting: In any position

Operating temperature range: -12 °C to 85 °C

On request: Special oils, or for higher or lower impact velocities outside range shown above, or other options please consult ACE.



The adjustable shock absorbers of the **ACE product series A1½ to A3** cover an **effective weight range from 0.3 kg up to 204 000 kg**. The robust A series units are designed for really heavy duty applications. The units are adjusted by means of a socket head screw in the rear end. The adjustable A series can replace the older SAHS series units with the same mounting dimensions. (Ask ACE for assistance.) The A units are maintenance-free and self-contained.

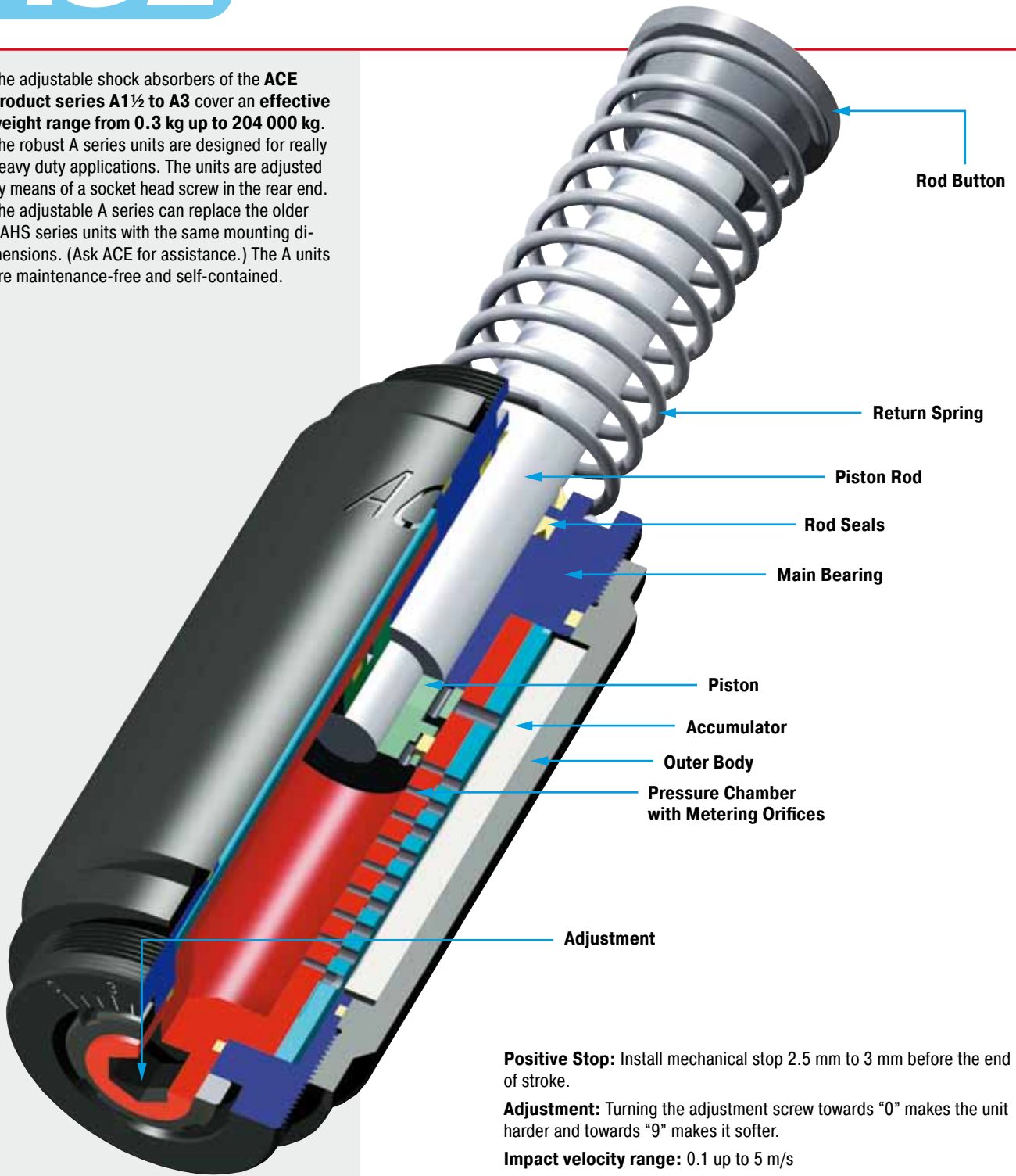

Rod Button

Return Spring

Piston Rod

Rod Seals

Main Bearing

Piston

Accumulator

Outer Body

Pressure Chamber with Metering Orifices

Adjustment

Positive Stop: Install mechanical stop 2.5 mm to 3 mm before the end of stroke.

Adjustment: Turning the adjustment screw towards "0" makes the unit harder and towards "9" makes it softer.

Impact velocity range: 0.1 up to 5 m/s

Operating fluid: Models A1½: HLP46 viscosity 46cSt. at 40 °C. Models A2 and A3: Automatic Transmission Fluid (ATF) viscosity 42 cSt. at 40 °C.

Material: Body and accessories: Steel with black oxide finish. Piston rod: Steel hardened and chrome plated. Rod end button: Steel hardened with black oxide finish. Return spring: Zinc plated. For optimum heat dissipation do not paint outer body.

Capacity rating: For emergency use only applications it may be possible to exceed published energy per cycle (W_3) figures. Please consult ACE for further details.

Mounting: In any position

Operating temperature range: -12 °C to 85 °C

On request: Special oils, or for higher or lower impact velocities outside range shown above, or other options please consult ACE.



Rear Flange -R

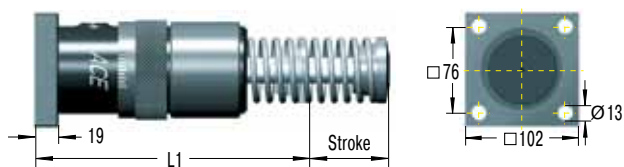

Front Flange -F

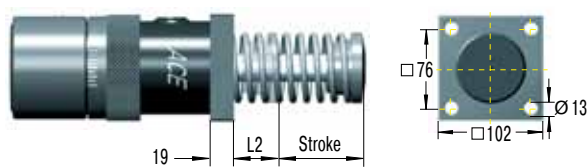

Clevis Mounting -C

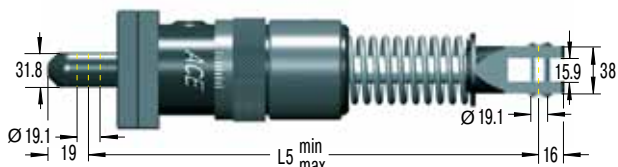

Due to limited force capacity the respective ability should be reviewed by ACE.

Foot Mounting -S

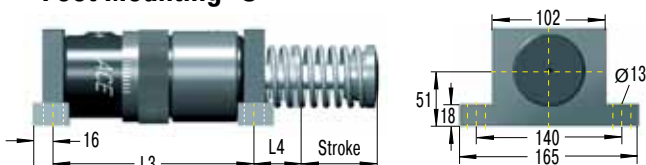

Not available on 2" stroke models.

Install mechanical stop 2.5 mm to 3 mm before end of stroke.

Ordering Example

Adjustable _____
 Bore Size Ø 1½" _____
 Stroke Length 2" = 50.8 mm _____
 EU Compliant _____
 Rear Flange Mounting _____

A1½x2EUR

Model Type Prefix

- A = self-contained with return spring
(This is standard model)
- AA = air/oil return without return spring.
Use only with external air/oil tank.
- NA = self-contained without return spring
- SA = air/oil return with return spring.
Use only with external air/oil tank.

Dimensions

Type	Stroke mm	L1	L2	L3	L4	L5
A1½x2EU	50	195.2	54.2	–	–	277.8 - 328.6
A1½x3½EU	89	233	54.2	170	58.6	316.6 - 405.6
A1½x5EU	127	271.5	54.2	208	58.6	354.8 - 481.8
A1½x6½EU	165	329	73	246	78	412 - 577

Capacity Chart

Type	Max. Energy Capacity			1 Effective Weight me		Min. Return Force N	Max. Return Force N	Rod Reset Time s	Max. Side Load Angle °	Weight kg
	2 W ₃ Nm/Cycle	3 W ₄ Self-Contained Nm/h	3 W ₄ with Air/Oil Tank Nm/h	me min. kg	me max. kg					
A1½x2EU	2 350	362 000	452 000	195	32 000	160	210	0.1	5	7.55
A1½x3½EU	4 150	633 000	791 000	218	36 000	110	210	0.25	4	8.9
A1½x5EU	5 900	904 000	1 130 000	227	41 000	90	230	0.4	3	9.35
A1½x6½EU	7 700	1 180 000	1 469 000	308	45 000	90	430	0.4	2	11.95

¹ The effective weight range limits can be raised or lowered to special order.

² For emergency use only applications it may be possible to exceed these max. capacity ratings. Please consult ACE for further details.

³ Figures for oil recirculation systems on request.

Rear Flange -R

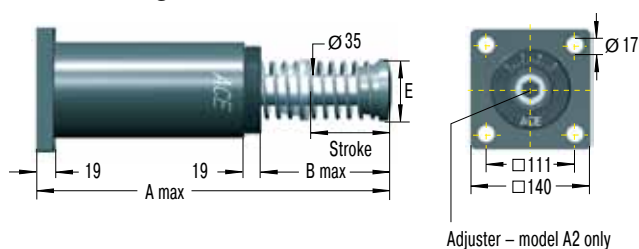

Front Flange -F

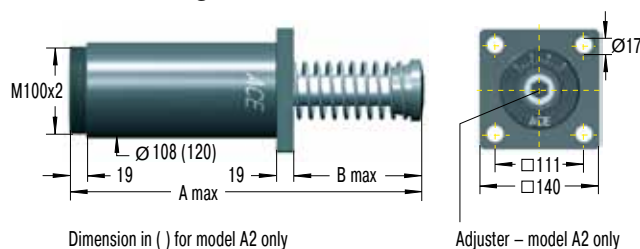

Foot Mounting -SM

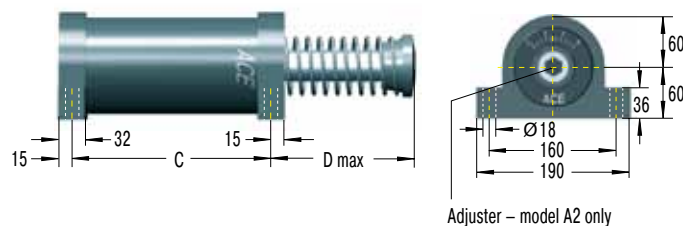

Dimensions of clevis mountings available on request.

NOTE! For replacement of existing SAHS 2" foot mounted units order the old type foot mounting S2-A.

Ordering Example

Self-Compensating _____
 Bore Size Ø 2" _____
 Stroke Length 4" = 102 mm _____
 EU Compliant _____
 Effective Weight Range Version _____
 Front Flange Mounting _____

CA2x4EU-3F

Model Type Prefix

A, CA = self-contained with return spring
 (This is standard model)

AA, CAA = air/oil return without return spring.
 Use only with external air/oil tank.

NA, CNA = self-contained without return spring

SA, CSA = air/oil return with return spring.
 Use only with external air/oil tank.

Dimensions

Type	Stroke mm	A max	B max	C	D max	E
2x2EU	50	313	110	173	125	70
2x4EU	102	414	160	224	175	70
2x6EU	152	516	211	275	226	70
2x8EU	203	643	287	326	302	92
2x10EU	254	745	338	377	353	108

Capacity Chart CA2

Type	Max. Energy Capacity			1 Effective Weight me				Min. Return Force N	Max. Return Force N	Rod Reset Time s	Max. Side Load Angle °	Weight kg
	2 W ₃ Nm/Cycle	3 W ₄ Self-Contained Nm/h	3 W ₄ with Air/Oil Tank Nm/h	Soft		Hard						
				-1 min. max. kg	-2 min. max. kg	-3 min. max. kg	-4 min. max. kg					
CA2x2EU	3 600	1 100 000	1 350 000	700 - 2 200	1 800 - 5 400	4 500 - 13 600	11 300 - 34 000	210	285	0.25	3	12.8
CA2x4EU	7 200	1 350 000	1 700 000	1 400 - 4 400	3 600 - 11 000	9 100 - 27 200	22 600 - 68 000	150	285	0.5	3	14.8
CA2x6EU	10 800	1 600 000	2 000 000	2 200 - 6 500	5 400 - 16 300	13 600 - 40 800	34 000 - 102 000	150	400	0.6	3	16.9
CA2x8EU	14 500	1 900 000	2 400 000	2 900 - 8 700	7 200 - 21 700	18 100 - 54 400	45 300 - 136 000	230	650	0.7	3	19.3
CA2x10EU	18 000	2 200 000	2 700 000	3 600 - 11 000	9 100 - 27 200	22 600 - 68 000	56 600 - 170 000	160	460	0.80	3	22.8

Capacity Chart A2

Type	Max. Energy Capacity			1 Effective Weight me		Min. Return Force N	Max. Return Force N	Rod Reset Time s	Max. Side Load Angle °	Weight kg
	2 W ₃ Nm/Cycle	3 W ₄ Self-Contained Nm/h	3 W ₄ with Air/Oil Tank Nm/h	me min. kg	me max. kg					
A2x2EU	3 600	1 100 000	1 350 000	250	77 000	210	285	0.25	3	14.3
A2x4EU	9 000	1 350 000	1 700 000	250	82 000	150	285	0.5	3	16.7
A2x6EU	13 500	1 600 000	2 000 000	260	86 000	150	400	0.6	3	19.3
A2x8EU	19 200	1 900 000	2 400 000	260	90 000	230	650	0.7	3	22.3
A2x10EU	23 700	2 200 000	2 700 000	320	113 000	160	460	0.8	3	26.3

¹ The effective weight range limits can be raised or lowered to special order.

² For emergency use only applications it may be possible to exceed these max. capacity ratings. Please consult ACE for further details.

³ Figures for oil recirculation systems on request.

Rear Flange -R

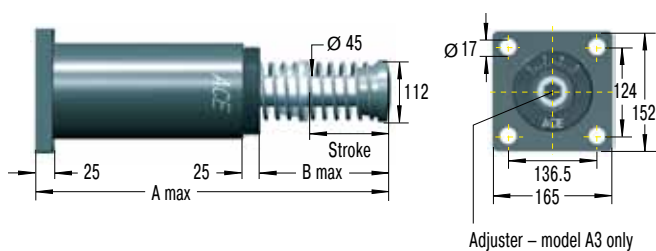

Front Flange -F

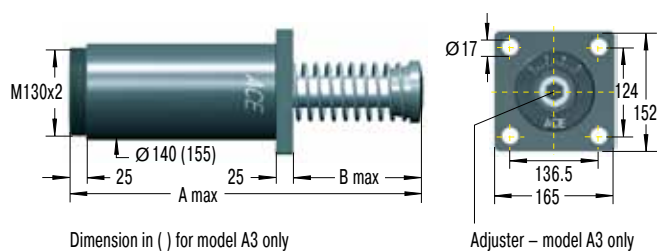

Foot Mounting -S

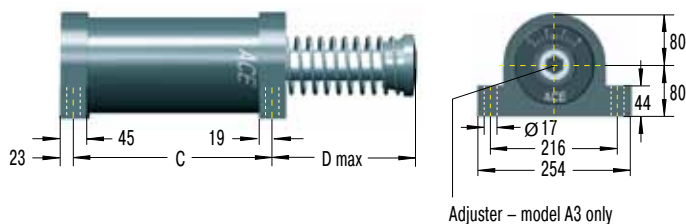

Dimensions of clevis mountings available on request.

NOTE! For replacement of existing SAHS 3" foot mounted units please consult ACE.

Ordering Example

Adjustable _____
 Bore Size Ø 3" _____
 Stroke Length 8" = 203 mm _____
 EU Compliant _____
 Rear Flange Mounting _____

A3x8EUR

Model Type Prefix

- A, CA = self-contained with return spring
(This is standard model)
- AA, CAA = air/oil return without return spring.
Use only with external air/oil tank.
- NA, CNA = self-contained without return spring
- SA, CSA = air/oil return with return spring.
Use only with external air/oil tank.

Abmessungen

Type	Hub mm	A max	B max	C	D max
3x5EU	127	490,5	211	254	224
3x8EU	203	641	286	330	300
3x12EU	305	890	434	432	447

Capacity Chart CA3

Type	Max. Energy Capacity			1 Effective Weight me				Min. Return Force N	Max. Return Force N	Rod Reset Time s	Max. Side Load Angle °	Weight kg
	2 W ₃ Nm/Cycle	3 W ₄ Self-Contained Nm/h	3 W ₄ with Air/Oil Tank Nm/h	Soft		Hard						
				-1 min. kg	-2 max. kg	-3 min. kg	-4 max. kg					
CA3x5EU	14 125	2 260 000	2 800 000	2 900 - 8 700	7 250 - 21 700	18 100 - 54 350	45 300 - 135 900	270	710	0.6	3	28.9
CA3x8EU	22 600	3 600 000	4 520 000	4 650 - 13 900	11 600 - 34 800	29 000 - 87 000	72 500 - 217 000	280	740	0.8	3	33.4
CA3x12EU	33 900	5 400 000	6 780 000	6 950 - 20 900	17 400 - 52 200	43 500 - 130 450	108 700 - 326 000	270	730	1.2	3	40.6

Capacity Chart A3

Type	Max. Energy Capacity			1 Effective Weight me		Min. Return Force N	Max. Return Force N	Rod Reset Time s	Max. Side Load Angle °	Weight kg
	2 W ₃ Nm/Cycle	3 W ₄ Self-Contained Nm/h	3 W ₄ with Air/Oil Tank Nm/h	me min. kg	me max. kg					
A3x5EU	15 800	2 260 000	2 800 000	480	154 000	270	710	0.6	3	35.5
A3x8EU	28 200	3 600 000	4 520 000	540	181 500	280	740	0.8	3	39.6
A3x12EU	44 000	5 400 000	6 780 000	610	204 000	270	730	1.2	3	35.5

¹ The effective weight range limits can be raised or lowered to special order.

² For emergency use only applications it may be possible to exceed these max. capacity ratings. Please consult ACE for further details.

³ Figures for oil recirculation systems on request.

Rear Flange -R

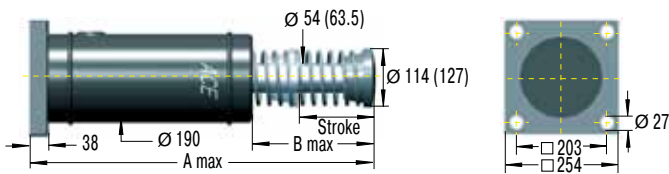

Dimension in () for model CA4x16 only

Front Flange -F

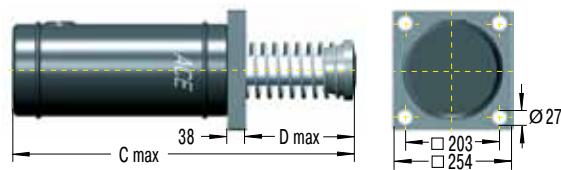

6 Tapped Holes (Primary Mounting) FRP

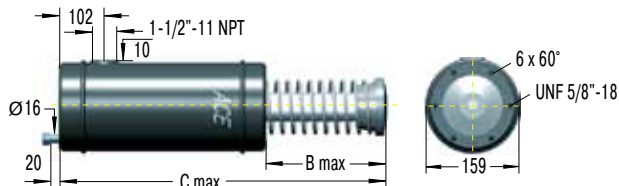

Foot Mounting -S

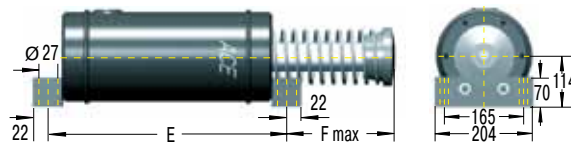

Dimensions of clevis mountings available on request.

Ordering Example

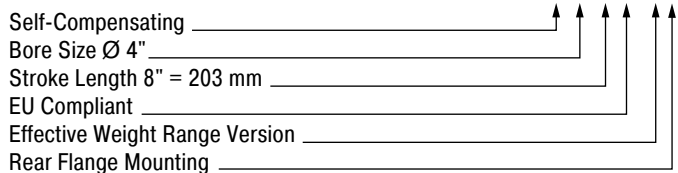

Model Type Prefix

- CA = self-contained with return spring
(This is standard model)
- CAA = air/oil return without return spring.
Use only with external air/oil tank.
- CNA = self-contained without return spring
- CSA = air/oil return with return spring.
Use only with external air/oil tank.

Dimensions CA/CNA/CSA

Type	Stroke mm	A	B	C	D	E	F
4x6EU	152	716	278	678	240	444	256
4x8EU	203	818	329	780	291	495	307
4x16EU	406	1 300	608.5	1 262.6	569	698	585

Dimensions of type CAA available on request.

Capacity Chart CA4

Type	Max. Energy Capacity				1 Effective Weight me				Min. Return Force N	Max. Return Force N	Rod Reset Time s	Weight kg
	² W ₃ Nm/Cycle	W ₄ Self- Contained Nm/h	W ₄ with Air/Oil Tank Nm/h	W ₄ with Oil Recirculation Nm/h	Soft		Hard					
					-3 min. max. kg	-5 min. max. kg	-7 min. max. kg					
CA4x6EU	47 500	3 000 000	5 100 000	6 600 000	3 500 - 8 600	8 600 - 18 600	18 600 - 42 700	480	1 000	1.8	60	
CA4x8EU	63 300	3 400 000	5 600 000	7 300 000	5 000 - 11 400	11 400 - 25 000	25 000 - 57 000	310	1 000	2.3	68	
CA4x16EU	126 500	5 600 000	9 600 000	12 400 000	10 000 - 23 000	23 000 - 50 000	50 000 - 115 000	310	1 000	Ask	146	

¹ The effective weight range limits can be raised or lowered to special order.

² For emergency use only applications it may be possible to exceed these max. capacity ratings. Please consult ACE for further details.

1 ACE Shock absorbers for pneumatic cylinders

For: optimum deceleration
 higher speeds
 smaller cylinders
 reduced air consumption
 smaller valves and pipework

Example: MA3350EUM-Z (cylinder mounting)

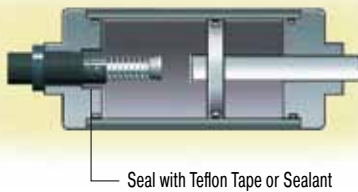

With heavy loads or high velocities normal cylinder cushions are often overloaded. This causes shock loading leading to premature cylinder failure or excessive maintenance. Using oversized cylinders to withstand this shock loading is not the best solution since this considerably increases air consumption and costs.

2 Side load adaptor for high side load angles

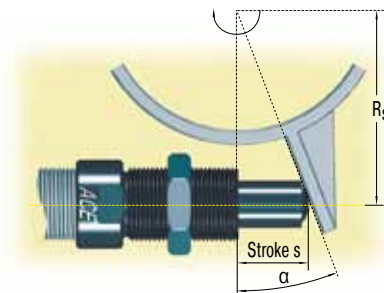

The side loading is removed from the shock absorber piston rod leading to considerably longer life. See pages 40 and 52 for more details.

3 Undamped free travel with damped end position

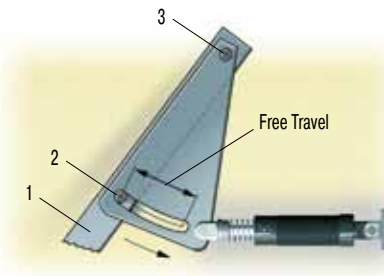

The lever 1 swings with the pin 2 in a slotted hole around pivot point 3. The lever is smoothly decelerated at the extreme end of its travel.

4 One shock absorber for both ends of travel

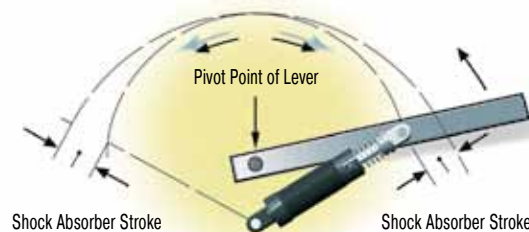

It is possible to use only one shock absorber for both end positions by using different pivot points as shown.

Tip: Leave approx. 1.5 mm of shock absorber stroke free at each end of travel.

5 Double acting shock absorber



With a little additional work a normal uni-directional shock absorber can be converted to work in 2 directions by using a mechanism as shown.

6 Air bleed collar



By using the air bleed adaptor the operating lifetime of shock absorbers in aggressive environments can be considerably increased. The adaptor protects the shock absorber seals from cutting fluids, cleaning agents, cooking oil etc. by using a low pressure air bleed. For more details see page 39.

7 Double stroke length



50 % lower reaction force (Q)

50 % lower deceleration (a)

By driving 2 shock absorbers against one another 'nose-to-nose', the effective stroke length can be doubled.

8 Ride over latch

8.1



8.2

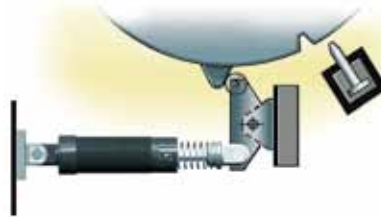

8.1 The latch absorbs the kinetic energy so that the object contacts the fixed stop gently.

8.2 The latch absorbs the rotational energy of the turntable etc. The turntable can then be held in the datum position with a lock bolt or similar.

9 Rotary actuator or rack and pinion drive

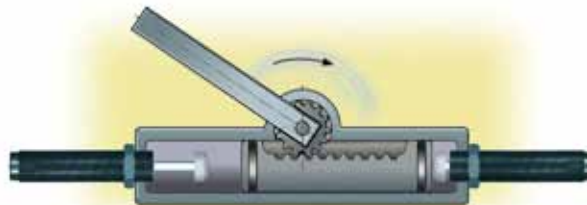

The use of ACE shock absorbers allows higher operating speeds and weights as well as protecting the drive mechanism and housing from shock loads.

10 Adjustable stop clamp e. g. for handling equipment

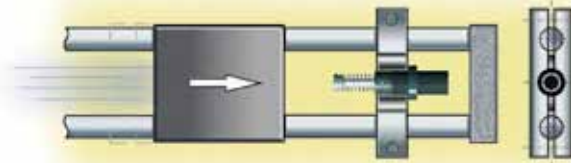

The gentle deceleration of ACE shock absorbers makes the use of adjustable stop clamps possible and removes any chance of the clamp slipping. The kinetic energy is completely removed before the mechanical stop is reached thus making high index speeds possible.

11 Ride-over latch e. g. fire door

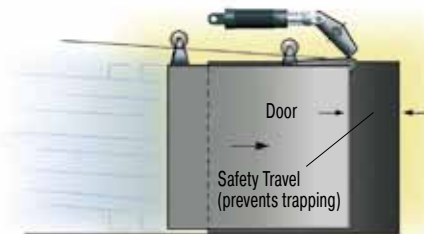

The fire door travels quickly until it reaches the lever. It is then gently decelerated by the lever mounted shock absorber and closes without shock or danger to personnel.

12 Increasing stroke length mechanically

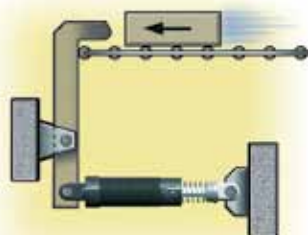

By means of a lever the effective stroke length can be increased and mounting space to the left reduced.



Constant resisting force

ACE miniature shock absorbers are the right alternative.

This pneumatic module for high precision, high speed motion intentionally abandoned pneumatic end-of-travel damping. The compact miniature shock absorbers of the type **MC25EUMH-NB** decelerate the linear motion safer and faster when reaching the end-of-travel position. They accept the moving load gently and decelerate it smoothly throughout the entire stroke length. Additional advantages: simpler construction, smaller pneumatic valves, lower maintenance costs as well as reduced compressed air consumption.



Miniature shock absorber in linear pneumatic module

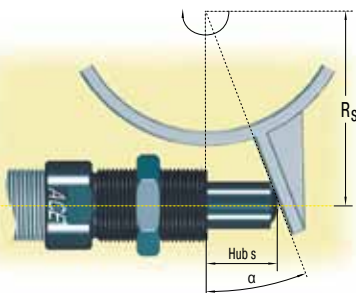

Soft end-of-travel damping on rotary movements

ACE miniature shock absorbers optimize production with minimum expenditure.

The cycle rate for an assembly line producing electronic components was increased to 3600 units/hr by using ACE shock absorbers. Miniature shock absorbers type **SC190EUM-1** decelerate the rapid transfer movements on the production line and using soft damping methods optimize the pick up and set down of components. This soft deceleration technique has increased production and reduced maintenance on the portal and rotary actuator modules. The optional side load adaptor protects the shock absorber from high side load forces and increases the operating lifetime. Using ACE shock absorbers reduces maintenance costs by 50% and running costs by 20%, diminishing energy consumption.



Optimised production in the electronics industry

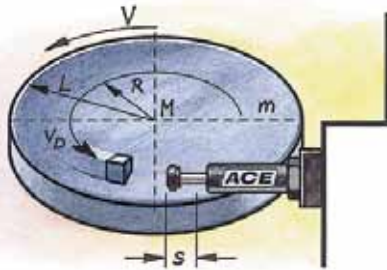

Safe swiveling

ACE industrial shock absorbers offer safety to spare for swiveling or braking of large telescope.

The optical system of this telescope for special observations is moveable in two space coordinates. The structure in which the telescope is mounted weighs 15 000 kg and consists of a turntable with drives and two wheel disks rotating on bearings. It enables a rotation by $\pm 90^\circ$ from horizon to horizon. To safeguard the telescope in case of overshooting the respective swiveling limits, industrial shock absorbers of the type **ML3325EUM** are used as braking elements. Should the telescope inadvertently overshoot the permissible swivel range, they will safely damp the travel of the valuable telescope.



Perfect overshoot protection for precision telescope

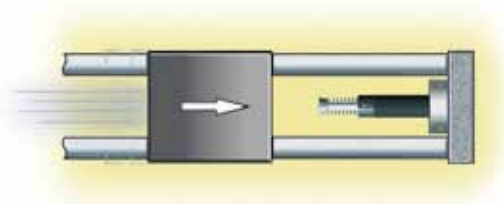

Quicker, gentle positioning

ACE industrial shock absorbers optimize portal for machine loading and increase productivity.

This device driven by piston rodless pneumatic cylinders, in which two gripper slides are moving independently of each other at speeds of 2 to 2.5 m/sec., is equipped with industrial shock absorbers as brake systems. Their function is to stop a mass of 25 kg up to 540 times per hour. The model **MC3350EUM-1-S** was chosen for this application, allowing easy and extremely accurate adjustment of the end positions of the adjustable limit stops. In comparison to brake systems with other function principles, shock absorbers allow higher travel speeds and shorter cycle sequences.

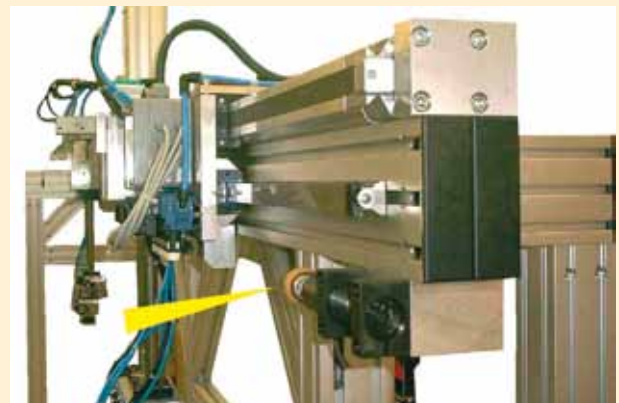

Industrial shock absorbers optimize portal operation