

VC precision feed controls are sealed hydraulic units fitted with a high precision metering element. When the piston rod is depressed the hydraulic oil is forced through the adjustable precision metering orifice. This provides a constant and precise feed control throughout the stroke length. The feed rate can be adjusted over a wide range by turning the external adjuster knob at the rear end of the unit. The threaded outer body makes installation and the adjustment of feed control travel limits very simple. **FA, MA and MVC** are similar feed control units intended for applications where the higher precision of the VC series is not required. Precision feed controls are self-contained, maintenance-free, temperature stable and stick-slip free. The rolling diaphragm seal provides a leakproof sealed unit and also provides an integral accumulator for the oil displaced during operation. The high precision, adjustable metering system can provide accurate feed rates from as low as 12 mm/min with light propelling forces. Applications include saws, cutters, drill feeds, grinding and boring machines in the plastics, metal, wood and glass industries.

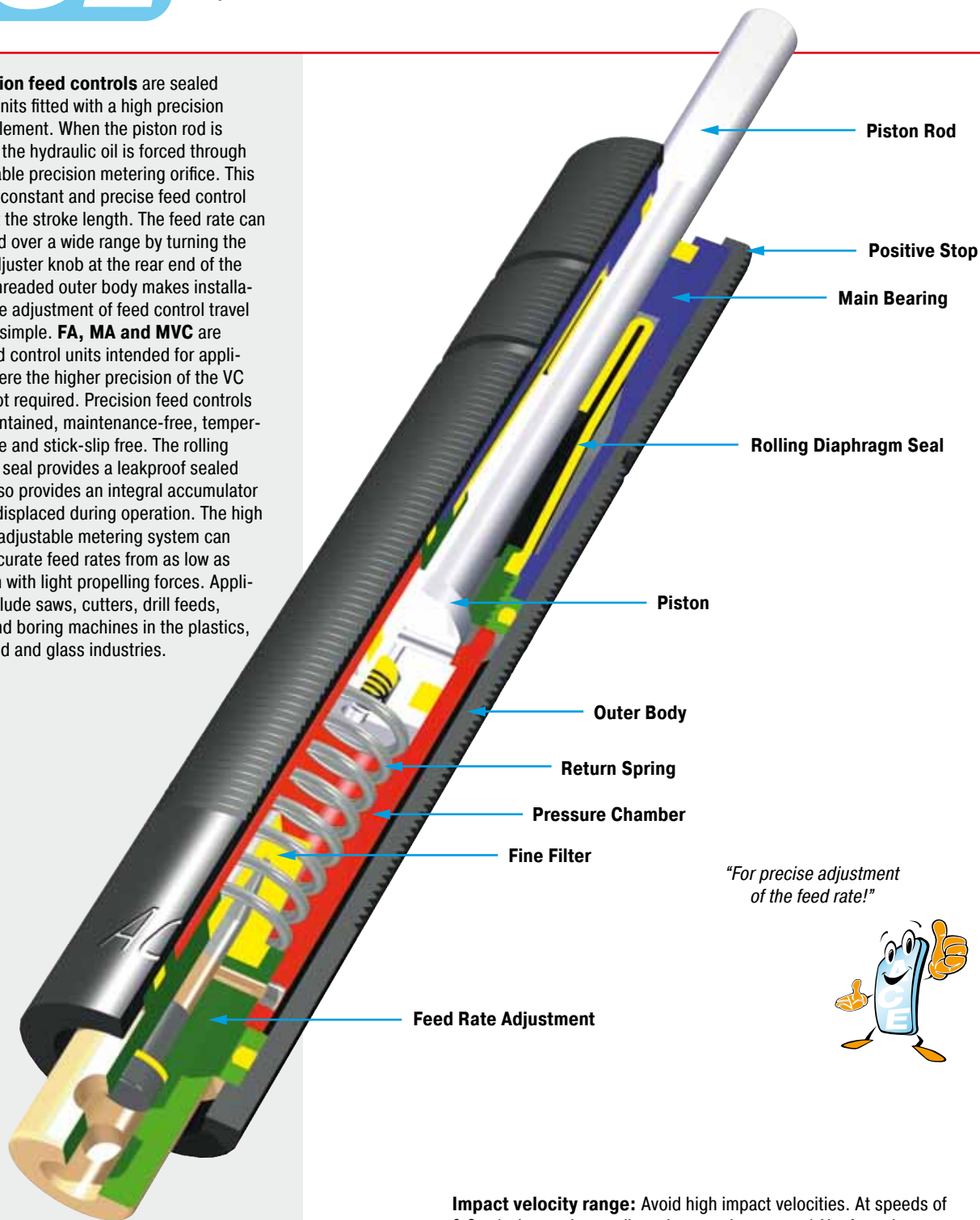

"For precise adjustment of the feed rate!"



Impact velocity range: Avoid high impact velocities. At speeds of 0.3 m/s the maximum allowed energy is approx. 1 Nm for units up to 55 mm stroke and approx. 2 Nm for units 74 mm to 125 mm stroke. Where higher energies occur use a shock absorber for the initial impact.

Material: Body heavy duty steel tube with black oxide. Piston rod with hard chrome plating.

Nylon button PP600 can be fitted onto piston rod. Unit may be mounted in any position.

When mounting: Take care not to damage the adjuster knob.

Operating temperature range: 0 °C to 60 °C

Only VC2515 to VC2555: Do not rotate piston rod, if excessive rotation force is applied rolling seal may rupture. In contact with petroleum base oils or cutting fluids specify optional neoprene rolling seal or install air bleed adaptor type SP.



VC25

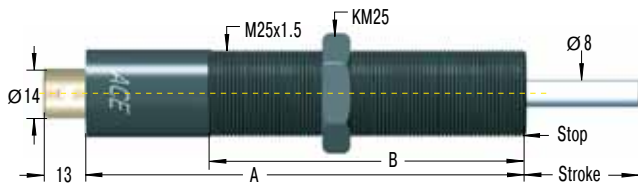

SP25

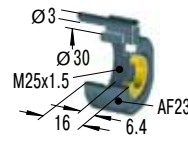

Air Bleed Collar

for VC2515FT to VC2555FT
reduction of the stroke 6.4 mm

MB25

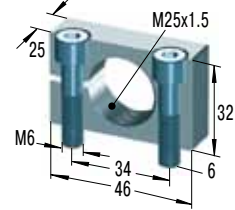

Clamp Mount

Accessories, mounting, installation ... see pages 38 to 41.

Capacity Chart

Type Part Number	Stroke mm	A	B	Min. Propelling Force N	Max. Propelling Force N	Min. Return Force N	Max. Return Force N	Rod Reset Time s	Max. Side Load Angle °	Weight kg
VC2515EUFT	15	128	80	30	3 500	5	10	0.2	3	0.35
VC2530EUFT	30	161	110	30	3 500	5	15	0.4	2	0.45
VC2555EUFT	55	209	130	35	3 500	5	20	1.2	2	0.6
VC2575EUFT	75	283	150	50	3 500	10	30	1.7	2	0.681
VC25100EUFT	100	308	150	60	3 500	10	35	2.3	1	0.794
VC25125EUFT	125	333.5	150	70	3 500	10	40	2.8	1	0.908

Suffix "FT" signifies a M25x1.5 threaded body.

Suffix "F" signifies a plain body 23.8 mm dia. (without thread) also available, with optional clamp type mounting block.

Technical Data

Outer body: Plain body 23.8 mm dia. (without thread) is also available.

Feed rate range: Min. 0.013 m/min with 400 N propelling force, max. 38 m/min with 3500 N propelling force.

Mounting Examples



Mounting with clamp mount MB25



Installed with air bleed collar SP25



Installed with switch stop collar inc. proximity switch and steel button AS25 plus PS25

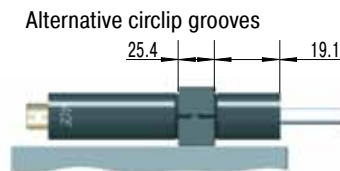

Alternative circlip grooves

Bulkhead mounting for VC25...F with mounting block KB... (23.8 mm plain body option)

Operating Range VC

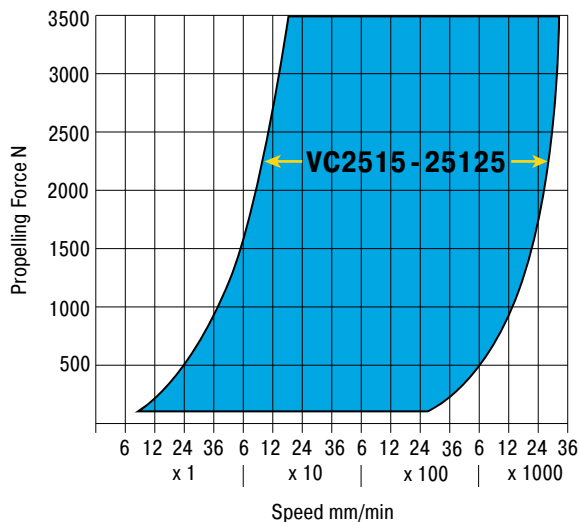

MA30EUM

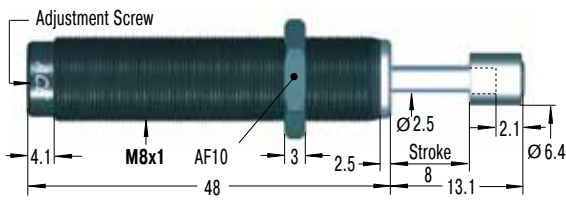

Accessories, mounting, installation ... see pages 36 to 41.

MA50EUM for use on new installations

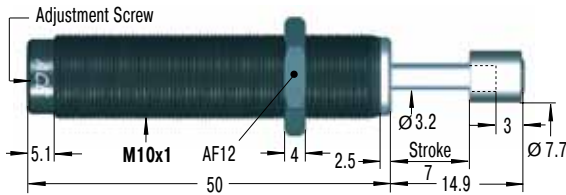

Accessories, mounting, installation ... see pages 36 to 41.

MA35EUM

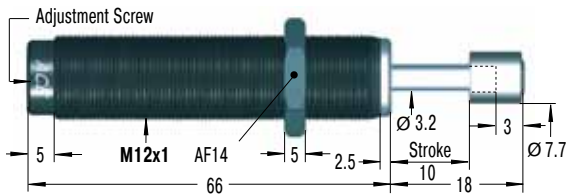

Accessories, mounting, installation ... see pages 37 to 41.

MA150EUM

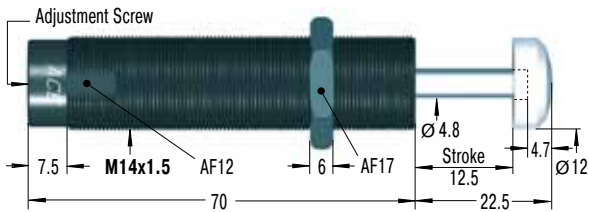

M14x1.5 also available to special order

Accessories, mounting, installation ... see pages 37 to 41.

MVC225EUM

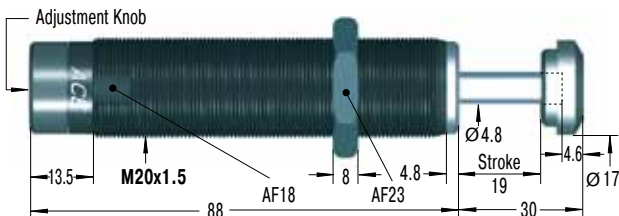

Accessories, mounting, installation ... see pages 38 to 41.

MVC600EUM and MVC900EUM

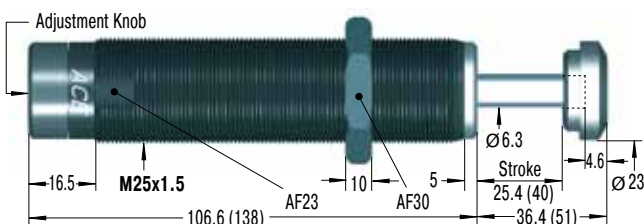

Dimensions for MVC900EUM in ()

Accessories, mounting, installation ... see pages 38 to 41.

RF8

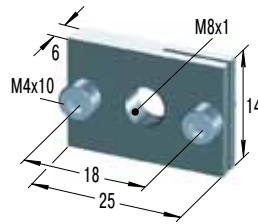

Rectangular Flange

MB8SC2

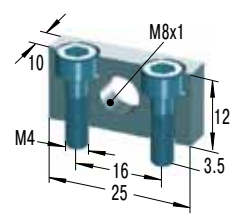

Mounting Block

FA1008V-B still available in future

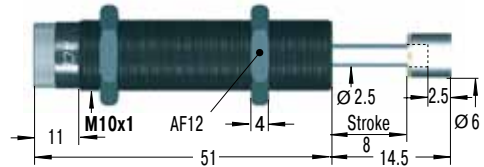

Accessories, mounting, installation ... see pages 36 to 41.

RF12

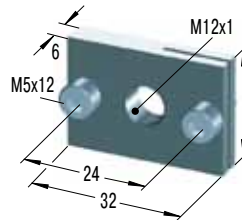

Rectangular Flange

MB12

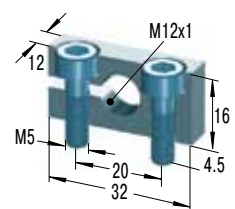

Clamp Mount

RF14

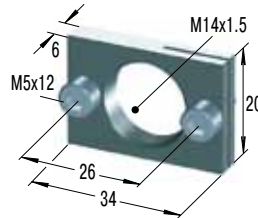

Rectangular Flange

MB14

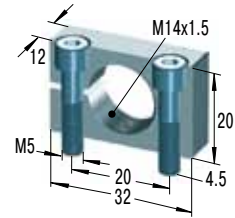

Clamp Mount

RF20

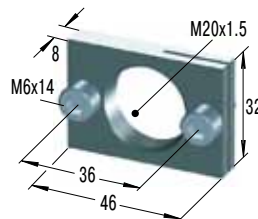

Rectangular Flange

MB20

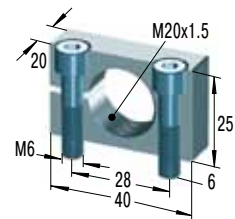

Clamp Mount

RF25

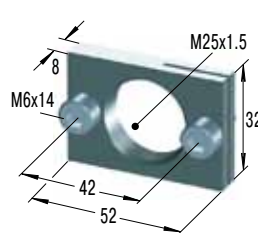

Rectangular Flange

MB25

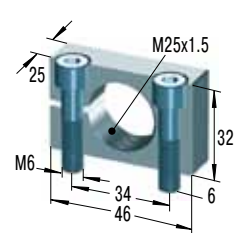

Clamp Mount

Capacity Chart

Type	Hub mm	Propelling Force N		Min. Return Force N	Max. Return Force N	Rod Reset Time s	1 Max. Side Load Angle °	Weight kg
		min. N	max. N					
MA30EUM	8	8	80	1.7	5.3	0.3	2	0.013
MA50EUM	7	40	160	3	6	0.3	2	0.025
FA1008V-B	8	10	180	3	6	0.3	2.5	0.024
MA35EUM	10	15	200	5	11	0.2	2	0.043
MA150EUM	12	20	300	3	5	0.4	2	0.06
MVC225EUM	19	25	1 750	5	10	0.65	2	0.15
MVC600EUM	25	65	3 500	10	30	0.85	2	0.3
MVC900EUM	40	70	3 500	10	35	0.95	2	0.4

¹ For applications with higher side load angles consider using the side load adaptor (BV) page 40.

Technical Data

Impact velocity range: Avoid high impact velocities. At speeds of 0.3 m/s the maximum allowed energy is approx. 2 Nm. Where higher energies occur use a shock absorber for the initial impact.

Mounting: In any position

Positive stop: Install mechanical stop 0.5 to 1 mm before end of stroke on model FA1008V-B.

Material: Body: Steel with black oxide finish. Piston rod: Stainless steel.

Operating temperature range: 0 °C to 66 °C

Operating Range MVC225 to 900

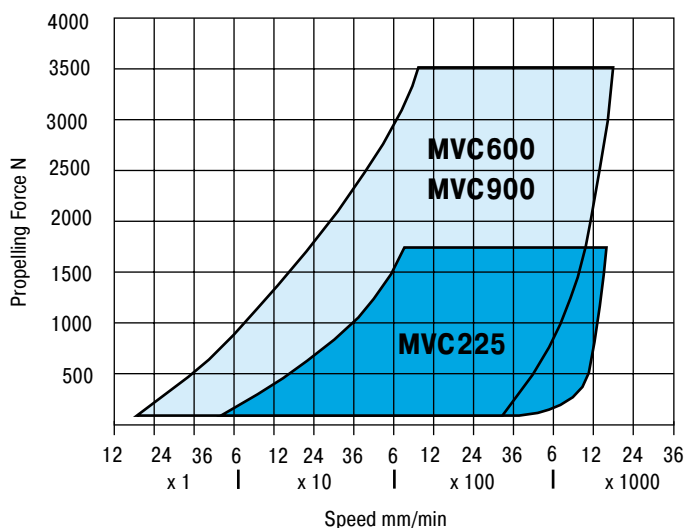

Application Examples

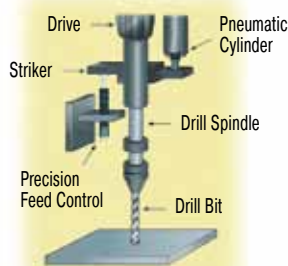

Drilling sheet metal

A high force is necessary at the start of drilling when the drill first contacts the sheet. After the initial cut this high force causes the drill to break through. This results in jagged edges rather than a smooth clean hole and also causes tool breakage.

By installing an **ACE VC feed control** it is possible to precisely control the rate of drill advance. As a result the drilled holes are clean and consistent and drill breakage is considerably reduced.

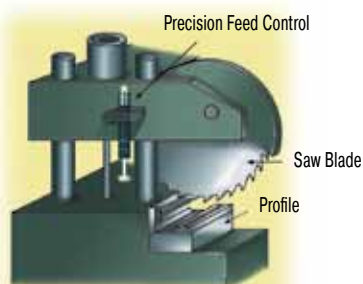

Sawing aluminium and plastic profiles

Varying material types, hardness and wear on the saw blade causes the cutting pressure to vary greatly. However the saw advance speed should remain constant as changes cause breakage of the material being cut or of the saw blade.

An **ACE VC feed control** fitted directly to the cutting head provides a simple and low cost solution. The cutting speed remains constant and can be easily preset.

Hydraulic speed/feed controls from ACE are maintenance-free, self-contained sealed units for precise control of speed in both directions of travel. The travel speed can be adjusted independently in each direction of travel. Applications include pick and place, machine slides and guards, flaps and hoods etc. The wide variety of mounting accessories make the DVC easy to install on many different types of application.

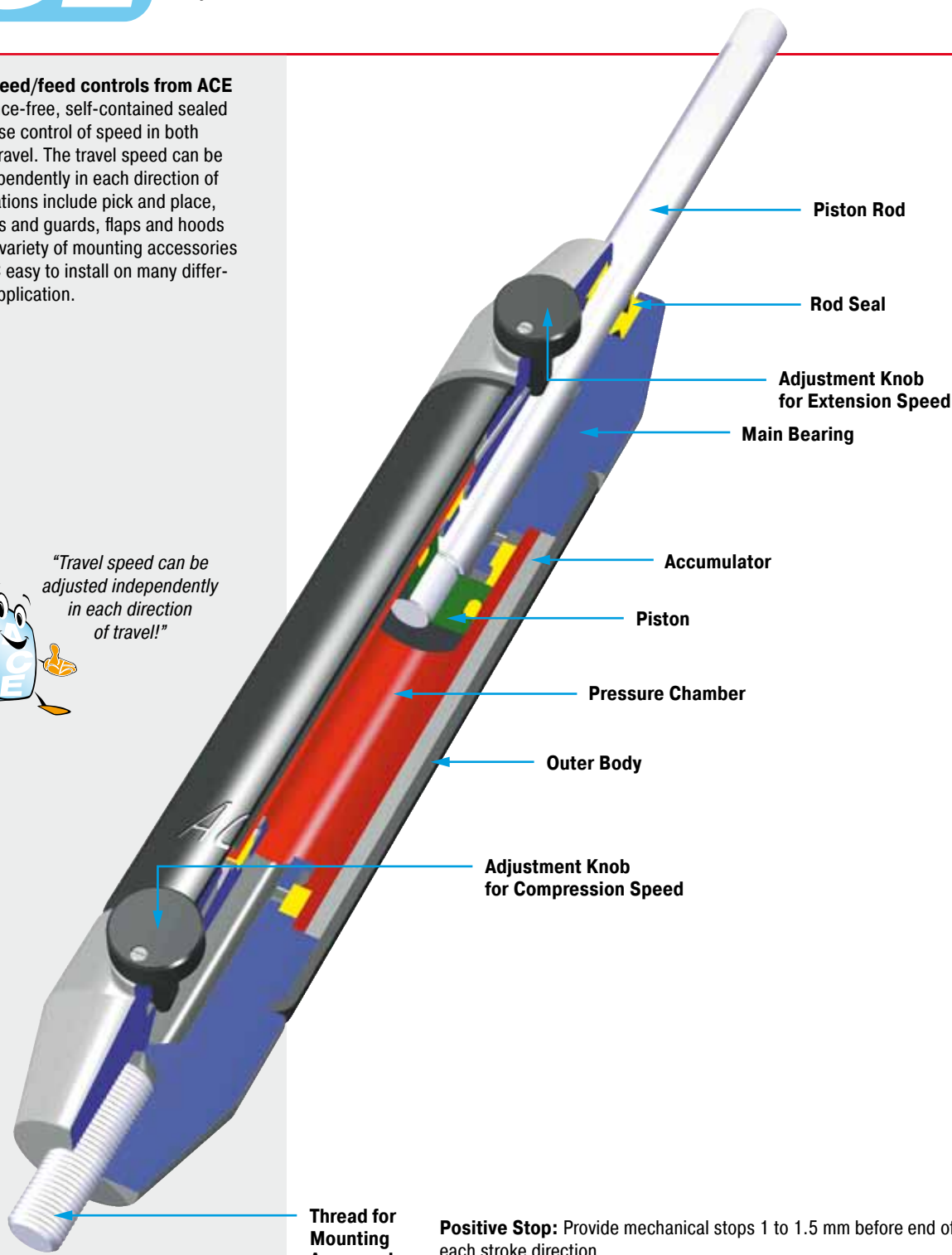
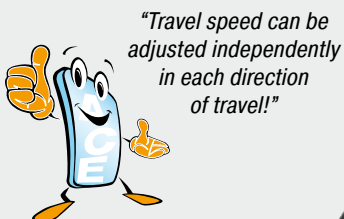

Positive Stop: Provide mechanical stops 1 to 1.5 mm before end of each stroke direction.

Operating fluid: Automatic Transmission Fluid (ATF) viscosity 42 cSt. at 40 °C

Material: Body: Black anodised aluminium. Piston rod: Hard chrome plated steel. End fittings: Zinc plated steel.

Note: If unit has not moved for some time the seals may dry causing an increased break-away force on the initial cycle.

Mounting: In any position. End fittings must be positively secured to prevent unscrewing.

Operating temperature range: 0 °C to 65 °C

On request: Special oils and external finishes. Uni-directional damping (free flow in reverse direction).



End Fitting

Standard Dimensions

End Fitting

A8

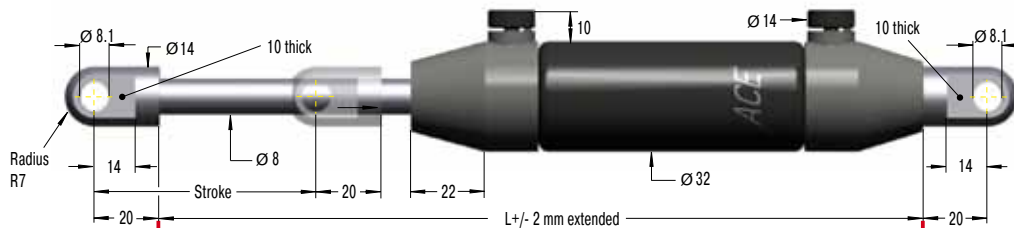

Eye A8
max. force 3000 N

B8



Dimensions

Type	Stroke mm	A max	B	L	Propelling Force N			
					Extension min	Extension max	Compression min	Compression max
DVC-32-50EU	50			240	42	2 000	42	2 000
DVC-32-50EU-XX	50	250	75.2		42	2 000	42	2 000
DVC-32-100EU	100			340	42	2 000	42	1 670
DVC-32-100EU-XX	100	350	124.4		42	2 000	42	1 670
DVC-32-150EU	150			440	42	2 000	42	1 335
DVC-32-150EU-XX	150	450	173.6		42	2 000	42	1 335

Stud Thread B8

C8

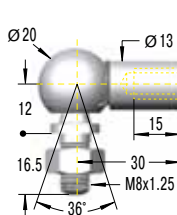

Angle Ball Joint C8
max. force 1200 N

D8

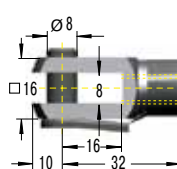

Clevis Fork D8
max. force 3000 N

E8

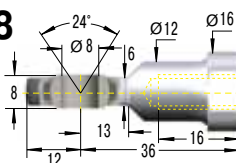

Swivel Eye E8
max. force 3000 N

Ordering Example

DVC-32-50EU-DD-P

Type (Hydraulic Damper) _____
 Body Ø (32 mm) _____
 Stroke (50 mm) _____
 EU Compliant _____
 Piston Rod End Fitting D8 _____
 Body End Fitting D8 _____
 Damping Direction (P = both directions) _____

Damping Options

P = Damping in both directions (standard model)
 M = Damping on out stroke only (adjustment knob at "rear end" free flow)
 N = Damping on in stroke only (adjustment knob at "piston rod end" free flow)

The end fittings are interchangeable and must be positively secured by the customer to prevent unscrewing (i.e. Loctite). For mounting accessories see page 200.

Fixed End Fitting -XX

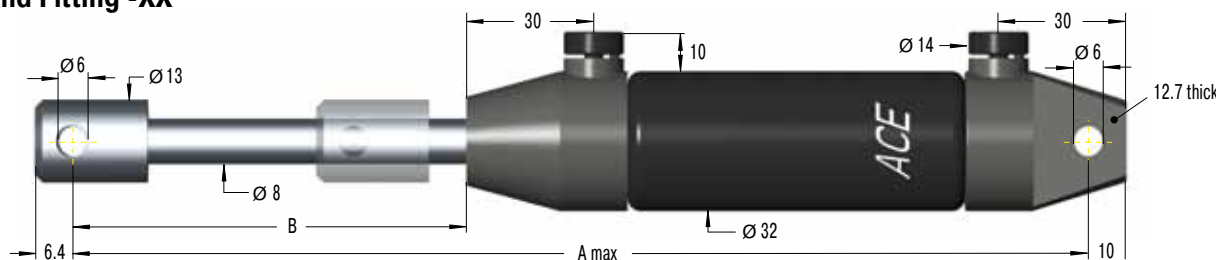

Compression Speed Control Chart

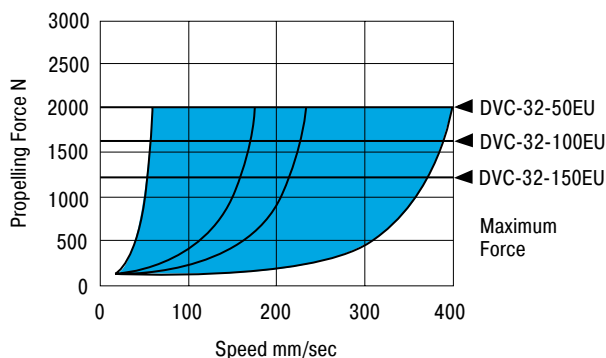

Tension Speed Control Chart

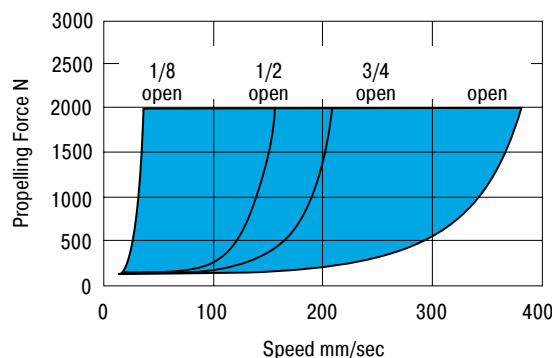

Hydraulic Dampers of ACE are maintenance-free, self contained sealed units, ready for use, for the precise control of damping in both directions of travel. The travel speed can be adjusted independently in each direction of travel at any time even during the stroke. The dampers are ideal for controlling swinging movements or as a variable resistance control on sports devices, exercise equipment and physiotherapy machines. Thanks to the new, high precision metering elements this damper ensures a constant feed rate independently controlled in each direction and the adjustment can be performed after mounting. The coated body and the steel-hardened and hard-chrome-plated piston rod stand for high quality and long lifetimes. The wide variety of mounting accessories make the **HBD** easy to install in many different types of applications.



NEW



Positive Stop: Provide a mechanical stop of 1 to 1.5 mm before the end of stroke in each direction.

Material: Piston rod: hard-chrome-plated steel. Body: black-coated steel.

Note: If unit has not moved for some time the seals may dry, causing an increased breakaway force on the initial cycle.

Mounting: In any position. End fittings must be positively secured to prevent unscrewing.

Operating temperature range: 0 °C to 65 °C

Maximum speed: 0.5 m/s

On request: Special lengths, stroke, alternative seals, end fittings and special oil.



NEW

End Fitting

Standard Dimensions

End Fitting

Dimensions

Type	Stroke mm	L extended	1 Max. Compression Force N
HBD-70-100	100	314	10 000
HBD-70-150	150	414	10 000
HBD-70-200	200	514	10 000
HBD-70-300	300	714	10 000
HBD-70-400	400	914	8 000
HBD-70-500	500	1 114	6 000

1 Max. extension force for all stroke lengths 10 000 N.

Ordering Example
HBD-70-300-EE
 Type (Hydraulic Damper) _____
 Body Ø (70 mm) _____
 Stroke (300 mm) _____
 Piston Rod End Fitting E14 _____
 Body End Fitting E14 _____

Damping Option Separately Adjustable

- Damping on out stroke only
- Damping on in stroke only
- Damping in both directions

The end fittings are interchangeable and must be positively secured by the customer to prevent unscrewing (i.e. Loctite). For mounting accessories see page 201.

End Fitting Options:
B14 Stud Thread B14
A14 Eye A14 max. force 10 000 N
C14 Angle Ball Joint C14 max. force 3200 N
D14 Clevis Fork D14 max. force 10 000 N
E14 Swivel Eye E14 max. force 10 000 N

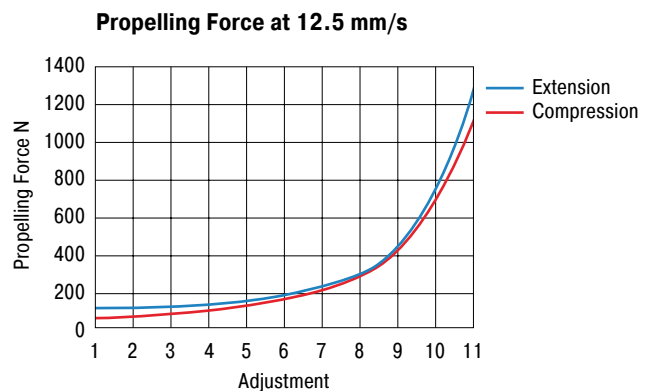
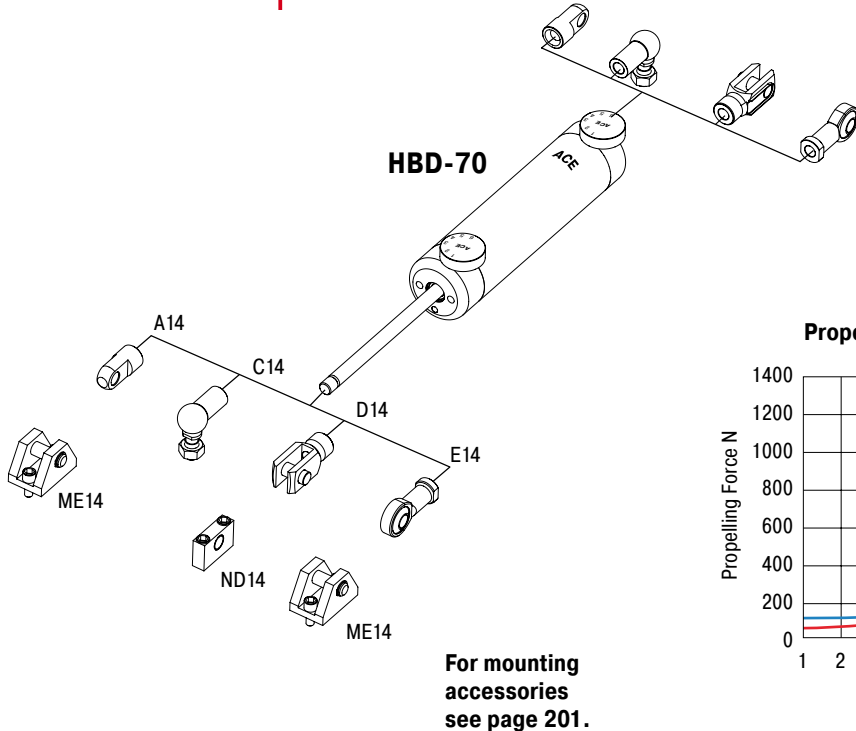

Hydraulic dampers from ACE are maintenance-free, self-contained and sealed units. They are available with body diameters from 28 mm up to 70 mm and with stroke lengths of up to 800 mm. As standard they are supplied as double acting dampers but a single acting version is also available. The single acting version is controllable in one direction only, with free flow in the opposite direction. The travel speed is adjustable and remains constant throughout the stroke. **The new adjustment segment on the piston makes sensitive speed adjustment easy.** ACE's hydraulic dampers sport the sleek design of our gas springs. **The zinc-plated outer body and the hard-chromed piston rod provide high quality and long life.** A wide range of screw on mounting accessories make them very versatile and easy to install. Typical applications include machine guards and lids, fire safety flaps and doors, damping oscillations of suspended loads (Power and Free Systems) etc. The stepless adjustment of the damping rate is achieved by pulling (or pushing) the piston rod to its fully extended (or compressed) position and then turning the piston rod.

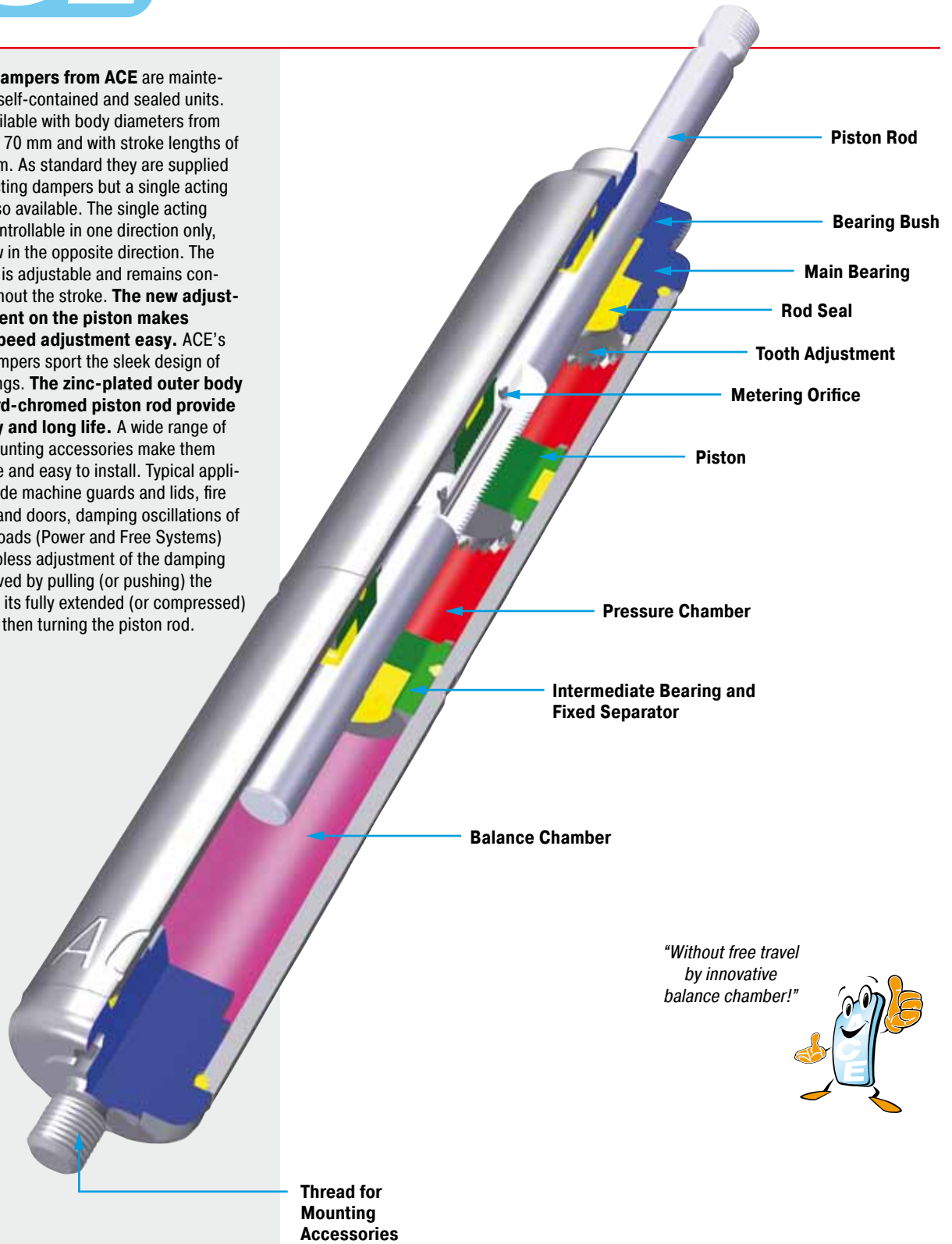

*"Without free travel
by innovative
balance chamber!"*



Operating fluid: Hydraulic oil

Note: If unit has not moved for some time the seals may dry, causing an increased breakaway force on the initial cycle.

Mounting: In any position. End fittings must be positively secured to prevent unscrewing.

Operating temperature range: -20 °C to 80 °C

On request: Special lengths, alternative seals and end fittings.



End Fitting

Standard Dimensions

End Fitting

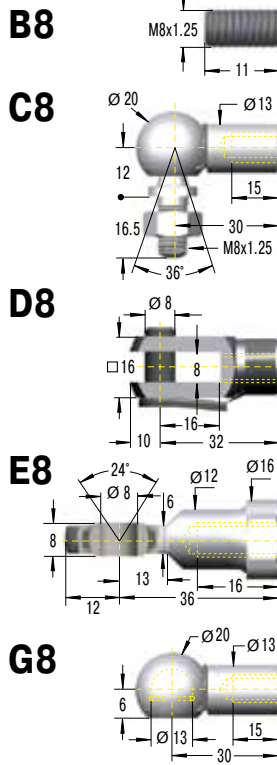
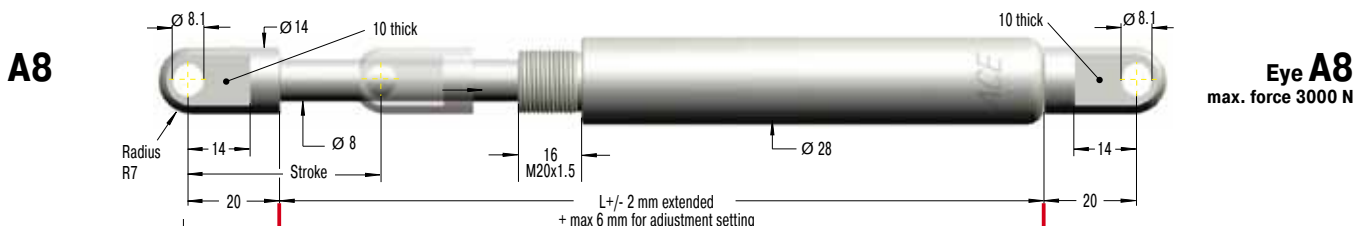

Dimensions					
Type	Stroke mm	L extended	¹ Max. Compression Force N	¹ Max. Compression Force with MBS N	
HBS-28-50	50	295	3 000	3 000	
HBS-28-100	100	445	1 550	3 000	
HBS-28-150	150	595	900	3 000	
HBS-28-200	200	745	600	3 000	
HBS-28-250	250	895	440	3 000	
HBS-28-300	300	1 045	330	3 000	
HBS-28-350	350	1 195	260	2 500	
HBS-28-400	400	1 345	200	2 000	

¹ Max. extension force for all stroke lengths 3000 N.

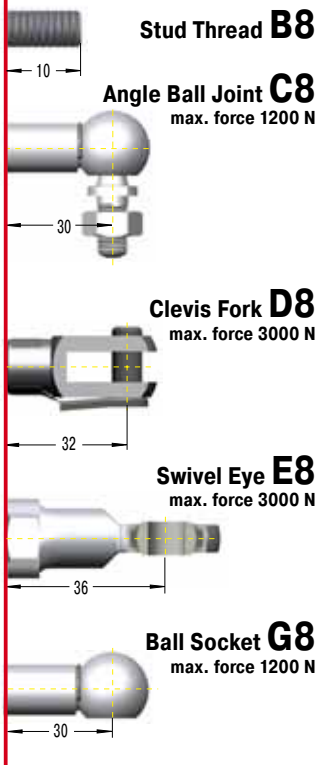

Ordering Example **HBS-28-150-DD-M**

Type (Hydraulic Damper) _____
 Body Ø (28 mm) _____
 Stroke (150 mm) _____
 Piston Rod End Fitting D8 _____
 Body End Fitting D8 _____
 Damping Direction (M = out stroke only) _____

- Damping Options**
- P = Damping in both directions
 - N = Damping on in stroke only
 - M = Damping on out stroke only
 - X = Special model suffix

The end fittings are interchangeable and must be positively secured by the customer to prevent unscrewing (i.e. Loctite). For mounting accessories see page 200.

Swivel Mounting Block MBS-28

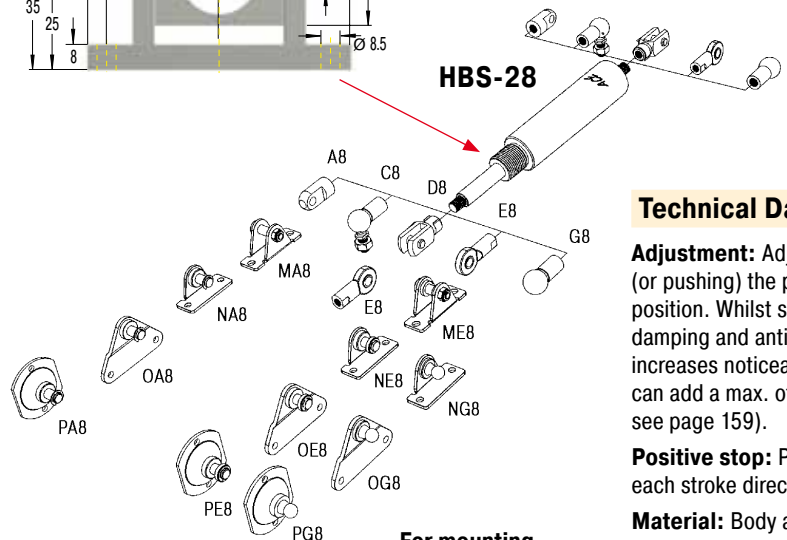
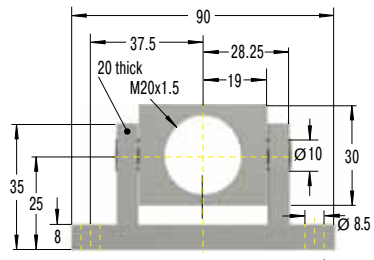

For mounting accessories see page 200.

Technical Data

Adjustment: Adjustment of the damping rate is achieved by pulling (or pushing) the piston rod to its fully extended (or compressed) position. Whilst still pulling the piston rod turn it clockwise to increase damping and anti-clockwise to decrease damping. If the resistance increases noticeably, stop adjusting to avoid damage. The adjustment can add a max. of 6 mm to the L dim. shown (adjustment instruction see page 159).

Positive stop: Provide mechanical stops 1 to 1.5 mm before end of each stroke direction.

Material: Body and end fittings: Zinc plated steel. Piston rod: Hard chrome plated.

Rod Shroud
no retrofit
Ø 32, L = Stroke + 50

End Fitting

Standard Dimensions

End Fitting

A10

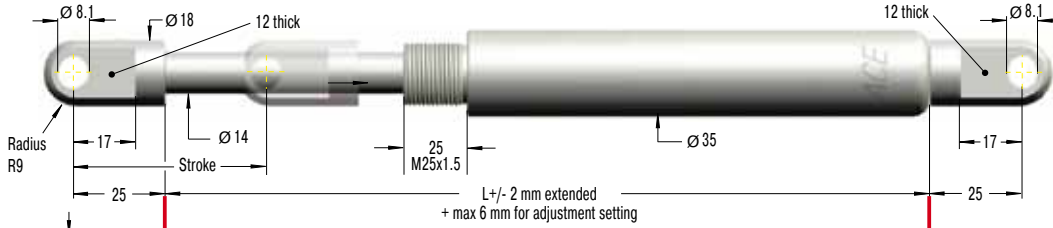

Eye A10
max. force 10 000 N

B10

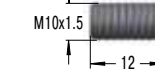

Stud Thread B10

C10

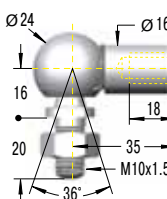

Angle Ball Joint C10
max. force 1800 N

D10

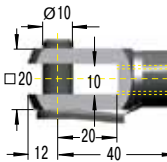

Clevis Fork D10
max. force 10 000 N

E10

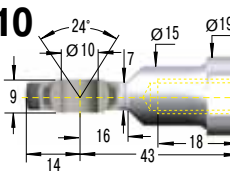

Swivel Eye E10
max. force 10 000 N

Swivel Mounting Block MBS-35

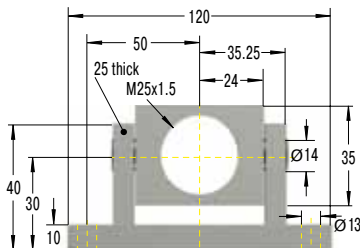

Dimensions					
Type	Stroke mm	L extended	¹ Max. Compression Force N	¹ Max. Compression Force with MBS N	
HBS-35-100	100	485	10 000	10 000	
HBS-35-150	150	635	7 500	10 000	
HBS-35-200	200	785	5 150	10 000	
HBS-35-300	300	1 085	2 850	10 000	
HBS-35-400	400	1 385	1 800	10 000	
HBS-35-500	500	1 685	1 240	10 000	
HBS-35-600	600	1 985	910	8 600	
HBS-35-700	700	2 285	690	6 500	
HBS-35-800	800	2 585	540	5 100	

¹ Max. extension force for all stroke lengths 10 000 N.

Ordering Example

HBS-35-300-EE-N

Type (Hydraulic Damper) _____
 Body Ø (35 mm) _____
 Stroke (300 mm) _____
 Piston Rod End Fitting E10 _____
 Body End Fitting E10 _____
 Damping Direction (N = in stroke only) _____

Damping Options

- P = Damping in both directions
- N = Damping on in stroke only
- M = Damping on out stroke only
- X = Special model suffix

The end fittings are interchangeable and must be positively secured by the customer to prevent unscrewing (i.e. Loctite). For mounting accessories see page 200.

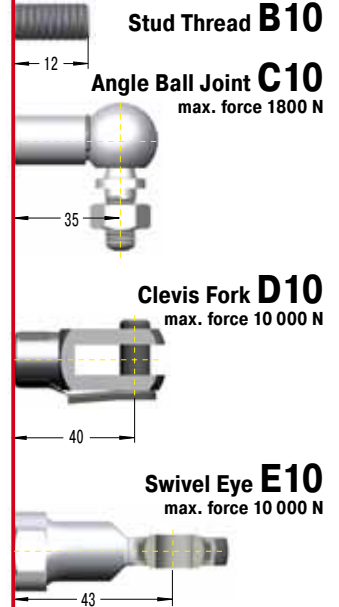

Rod Shroud
no retrofit
Ø 40, L = Stroke + 50

HBS-35

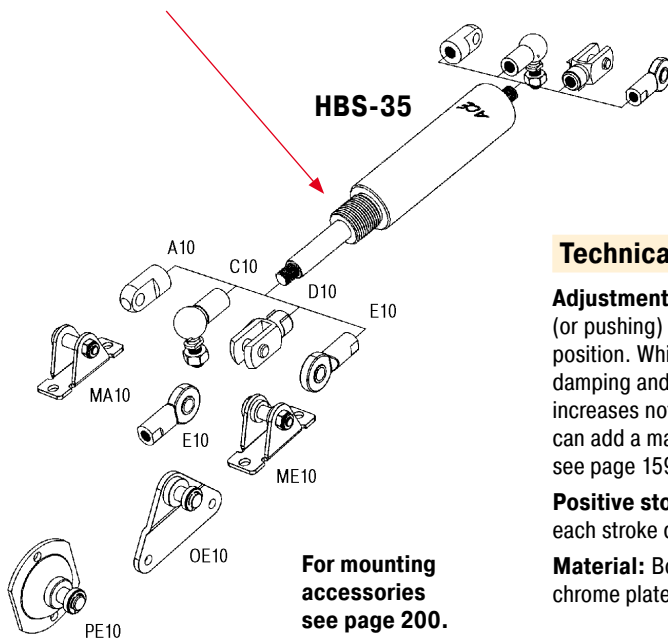

For mounting accessories see page 200.

Technical Data

Adjustment: Adjustment of the damping rate is achieved by pulling (or pushing) the piston rod to its fully extended (or compressed) position. Whilst still pulling the piston rod turn it clockwise to increase damping and anti-clockwise to decrease damping. If the resistance increases noticeably, stop adjusting to avoid damage. The adjustment can add a max. of 6 mm to the L dim. shown (adjustment instruction see page 159).

Positive stop: Provide mechanical stops 1 to 1.5 mm before end of each stroke direction.

Material: Body and end fittings: Zinc plated steel. Piston rod: Hard chrome plated.

End Fitting

Standard Dimensions

End Fitting

B24



Stud Thread **B24**

D24

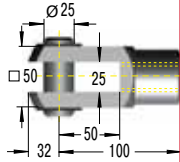

Clevis Fork **D24**
max. force 50 000 N

E24

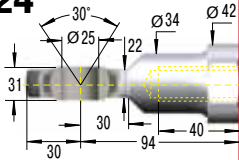

Swivel Eye **E24**
max. force 50 000 N

Swivel Mounting Block
MBS-70

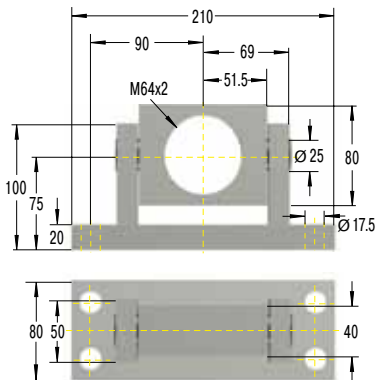

Dimensions

Type	Stroke mm	L extended	¹ Max. Compression Force N	¹ Max. Compression Force with MBS N
HBS-70-100	100	561	40 000	40 000
HBS-70-200	200	861	40 000	40 000
HBS-70-300	300	1 161	40 000	40 000
HBS-70-400	400	1 461	30 300	40 000
HBS-70-500	500	1 761	21 600	40 000
HBS-70-600	600	2 061	16 200	40 000
HBS-70-700	700	2 361	12 600	40 000
HBS-70-800	800	2 661	10 100	40 000

¹ Max. extension force for all stroke lengths 40 000 N.

Ordering Example

HBS-70-300-EE-N

Type (Hydraulic Damper) _____
 Body Ø (70 mm) _____
 Stroke (300 mm) _____
 Piston Rod End Fitting E24 _____
 Body End Fitting E24 _____
 Damping Direction (N = in stroke only) _____

Damping Options

- P = Damping in both directions
- N = Damping on in stroke only
- M = Damping on out stroke only
- X = Special model suffix

The end fittings are interchangeable and must be positively secured by the customer to prevent unscrewing (i.e. Loctite). For mounting accessories see page 201.

Rod Shroud **W24-70**
Ø 80, L = Stroke + 130

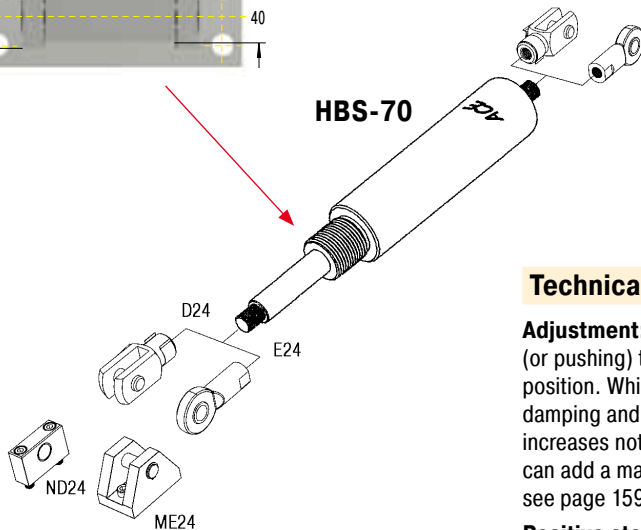

For mounting accessories see page 201.

Technical Data

Adjustment: Adjustment of the damping rate is achieved by pulling (or pushing) the piston rod to its fully extended (or compressed) position. Whilst still pulling the piston rod turn it clockwise to increase damping and anti-clockwise to decrease damping. If the resistance increases noticeably, stop adjusting to avoid damage. The adjustment can add a max. of 8 mm to the L dim. shown (adjustment instruction see page 159).

Positive stop: Provide mechanical stops 5 to 6 mm before end of each stroke direction.

Material: Body: Black powder coated steel or zinc plated steel. Piston rod: Hard chrome plated. End fittings: Zinc plated steel.

Hydraulic dampers from ACE are maintenance-free, self-contained and sealed units. They are available with body diameters from 12 mm up to 70 mm and with stroke lengths of up to 800 mm. As standard they are supplied as double acting dampers but a single acting version is also available. The single acting version is controllable in one direction only, with free flow in the opposite direction. The travel speed is adjustable and remains constant throughout the stroke. **The new adjustment segment on the piston makes sensitive speed adjustment easy.** ACE's hydraulic dampers sport the sleek design of our gas springs. **The coated body and the piston rod with a special wear-resistant coating provide an exceptionally long lifetime and excellent corrosion protection.** A wide range of screw on mounting accessories make them very versatile and easy to install. Typical applications include machine guards and lids, fire safety flaps and doors, damping oscillations of suspended loads (Power and Free Systems) etc.

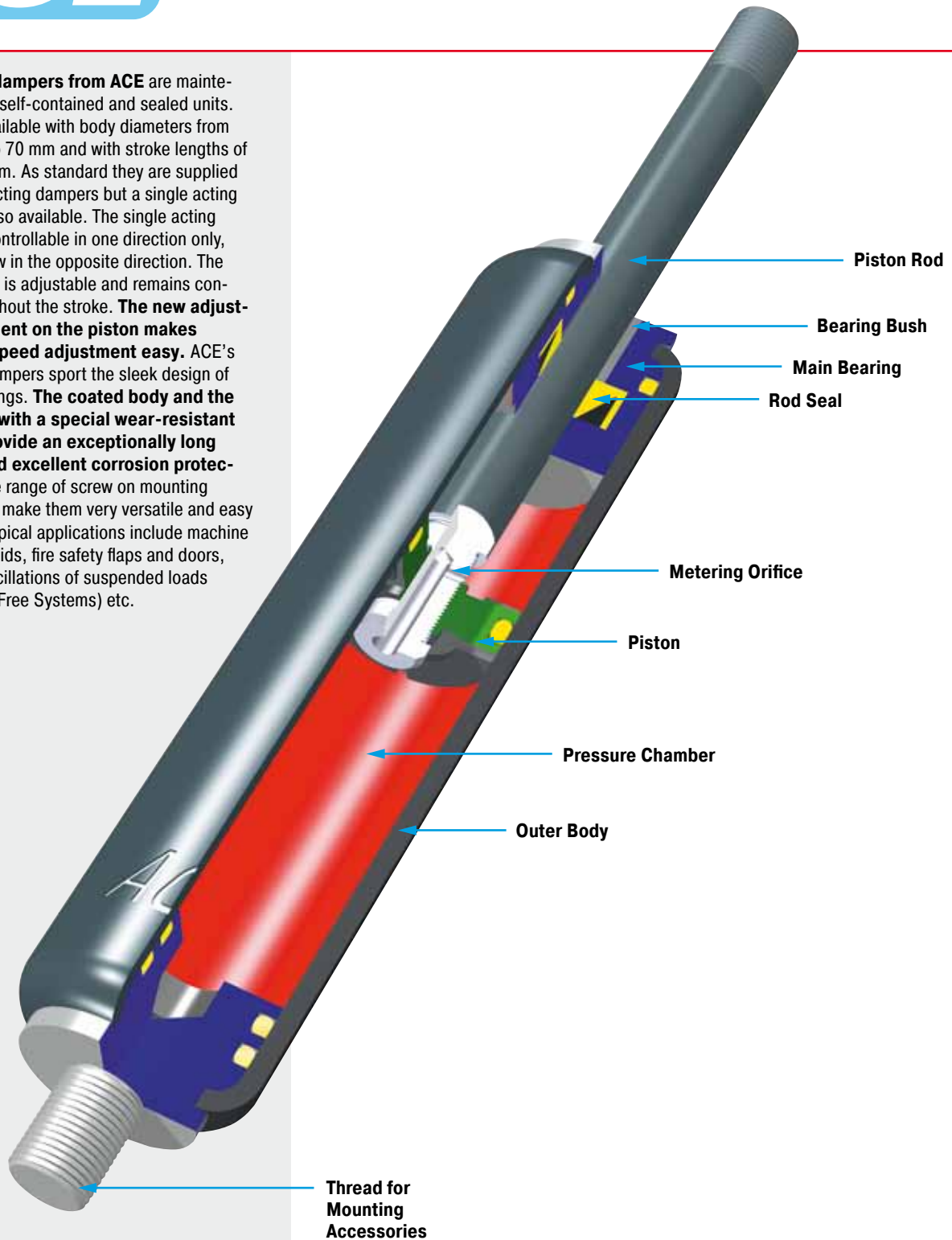

Function: The stepless adjustment of the damping rate is achieved by pulling (or pushing) the piston rod to its fully extended (or compressed) position and then turning the piston rod.

Operating fluid: Hydraulic oil

Mounting: In any position. End fittings must be positively secured to prevent unscrewing.

Operating temperature range: -20 °C to 80 °C

On request: Special lengths, alternative seals and end fittings.



End Fitting

Standard Dimensions

End Fitting

A3,5

B3,5

C3,5

D3,5

E3,5

G3,5

Rod Shroud W3,5-12

Dimensions

Type	Stroke mm	L extended	¹ Max. Compression Force N
HB-12-10	10	55	180
HB-12-20	20	75	180
HB-12-30	30	95	180
HB-12-40	40	115	180
HB-12-50	50	135	180
HB-12-60	60	155	180
HB-12-70	70	175	180
HB-12-80	80	195	150

¹ Max. extension force for all stroke lengths 180 N.

Ordering Example

HB-12-30-AC-M

Type (Hydraulic Damper) _____

Body Ø (12 mm) _____

Stroke (30 mm) _____

Piston Rod End Fitting A3,5 _____

Body End Fitting C3,5-M5 _____

Damping Direction (M = out stroke only) _____

Damping Options

P = Damping in both directions
 N = Damping on in stroke only
 M = Damping on out stroke only
 X = Special model suffix

The end fittings are interchangeable and must be positively secured by the customer to prevent unscrewing (i.e. Loctite). For mounting accessories see page 199.

Eye A3,5-M5
max. force 370 N

Stud Thread B3,5-M5

Angle Ball Joint C3,5-M5
max. force 370 N

Clevis Fork D3,5-M5
max. force 370 N

Swivel Eye E3,5-M5
max. force 370 N

Ball Socket G3,5-M5
max. force 370 N

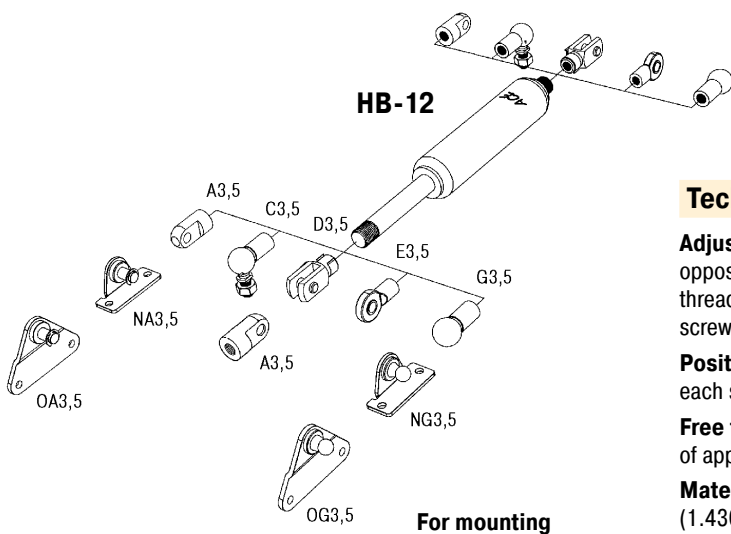

For mounting accessories see page 199.

Technical Data

Adjustment: Adjustment of the damping rate is handled, in the opposite way to the dampers HB-15 to HB-70, via the cylinder stud thread. The damping force can be precisely regulated by using a screwdriver (adjustment instruction see page 159).

Positive stop: Provide mechanical stops 1 to 1.5 mm before end of each stroke direction.

Free travel: Construction of standard damper results in a free travel of approx. 21 % of stroke.

Material: Body: Black coated steel. Piston rod: Stainless steel (1.4305). End fittings: Zinc plated steel.

Issue 6.2011 Specifications subject to change

End Fitting

Standard Dimensions

End Fitting

A5 Eye **A5**
max. force 800 N

B5 Stud Thread **B5**

C5 Angle Ball Joint **C5**
max. force 500 N

D5 Clevis Fork **D5**
max. force 800 N

E5 Swivel Eye **E5**
max. force 800 N

G5 Ball Socket **G5**
max. force 500 N

Dimensions

Type	Stroke mm	L extended	1 Max. Compression Force N
HB-15-25	25	90	800
HB-15-50	50	140	800
HB-15-75	75	190	800
HB-15-100	100	240	350
HB-15-150	150	340	300

¹ Max. extension force for all stroke lengths 800 N.

Ordering Example

HB-15-150-CC-M

Type (Hydraulic Damper) _____
 Body Ø (15.6 mm) _____
 Stroke (150 mm) _____
 Piston Rod End Fitting C5 _____
 Body End Fitting C5 _____
 Damping Direction (M = out stroke only) _____

Damping Options

- P = Damping in both directions
- N = Damping on in stroke only
- M = Damping on out stroke only
- X = Special model suffix

The end fittings are interchangeable and must be positively secured by the customer to prevent unscrewing (i.e. Loctite). For mounting accessories see page 199.

Rod Shroud W5-15

Ø19
L = Stroke + 20

HB-15

A5, C5, D5, E5, G5, MA5, NA5, OA5, PA5, PG5, NG5

For mounting accessories see page 199.

Technical Data

On request: Special lengths, alternative seals and end fittings.

Mounting: In any position. End fittings must be positively secured to prevent unscrewing.

Adjustment: Adjustment of the damping rate is achieved by pulling (or pushing) the piston rod to its fully extended (or compressed) position. Whilst still pulling the piston rod turn it clockwise to increase damping and anti-clockwise to decrease damping. If the resistance increases noticeably, stop adjusting to avoid damage. The adjustment can add a max. of 6 mm to the L dim. shown (adjustment instruction see page 159).

Positive stop: Provide mechanical stops 1 to 1.5 mm before end of each stroke direction.

Free travel: Construction of standard damper results in a free travel of approx. 20% of stroke.

Material: Body: Black coated steel. Piston rod: With wear-resistant coating. End fittings: Zinc plated steel.

End Fitting

Standard Dimensions

End Fitting

A8 Eye **A8**
max. force 3000 N

B8 Stud Thread **B8**

C8 Angle Ball Joint **C8**
max. force 1200 N

D8 Clevis Fork **D8**
max. force 3000 N

E8 Swivel Eye **E8**
max. force 3000 N

G8 Ball Socket **G8**
max. force 1200 N

Rod Shroud W8-22

Dimensions

Type	Stroke mm	L extended	1 Max. Compression Force N
HB-22-50	50	150	1 800
HB-22-100	100	250	1 800
HB-22-150	150	350	1 800
HB-22-200	200	450	1 000
HB-22-250	250	550	1 000

1 Max. extension force for all stroke lengths 1800 N.

Ordering Example **HB-22-150-DD-M**

Type (Hydraulic Damper) _____
 Body Ø (23 mm) _____
 Stroke (150 mm) _____
 Piston Rod End Fitting D8 _____
 Body End Fitting D8 _____
 Damping Direction (M = out stroke only) _____

Damping Options

- P = Damping in both directions
- N = Damping on in stroke only
- M = Damping on out stroke only
- X = Special model suffix

The end fittings are interchangeable and must be positively secured by the customer to prevent unscrewing (i.e. Loctite). For mounting accessories see page 200.

Stroke: 10 thick, 14, 20, 20, 14, 10 thick, Ø 8.1, Ø 14, Ø 8, Ø 23, L +/- 2 mm extended + max 6 mm for adjustment setting, Radius R7, M8x1.25, 9, Ø 20, Ø 13, 12, 15, 16.5, 30, 36°, M8x1.25, Ø 8, 16, 8, 10, 16, 32, 24°, Ø 8, 6, 12, 13, 36, 16, Ø 20, Ø 13, 6, Ø 13, 30, Ø 28, L = Stroke + 30

HB-22

A8, C8, D8, E8, G8, MA8, NA8, OA8, PA8, ME8, NE8, NG8, OE8, OG8, PE8, PG8

For mounting accessories see page 200.

Technical Data

On request: Special lengths, alternative seals and end fittings.

Mounting: In any position. End fittings must be positively secured to prevent unscrewing.

Adjustment: Adjustment of the damping rate is achieved by pulling (or pushing) the piston rod to its fully extended (or compressed) position. Whilst still pulling the piston rod turn it clockwise to increase damping and anti-clockwise to decrease damping. If the resistance increases noticeably, stop adjusting to avoid damage. The adjustment can add a max. of 6 mm to the L dim. shown (adjustment instruction see page 159).

Positive stop: Provide mechanical stops 1 to 1.5 mm before end of each stroke direction.

Free travel: Construction of standard damper results in a free travel of approx. 20% of stroke.

Material: Body: Black coated steel. Piston rod: With wear-resistant coating. End fittings: Zinc plated steel.

End Fitting

Standard Dimensions

End Fitting

A8 Eye A8 max. force 3000 N

B8 Stud Thread B8

C8 Angle Ball Joint C8 max. force 1200 N

D8 Clevis Fork D8 max. force 3000 N

E8 Swivel Eye E8 max. force 3000 N

G8 Ball Socket G8 max. force 1200 N

W8-28 Rod Shroud

Dimensions

Type	Stroke mm	L extended	1 Max. Compression Force N
HB-28-100	100	260	3 000
HB-28-150	150	360	3 000
HB-28-200	200	460	3 000
HB-28-250	250	560	3 000
HB-28-300	300	660	2 500
HB-28-350	350	760	2 000
HB-28-400	400	860	1 500
HB-28-500	500	1 060	1 000

1 Max. extension force for all stroke lengths 3000 N.

Ordering Example: **HB-28-150-DD-M**

Type (Hydraulic Damper) _____
 Body Ø (28 mm) _____
 Stroke (150 mm) _____
 Piston Rod End Fitting D8 _____
 Body End Fitting D8 _____
 Damping Direction (M = out stroke only) _____

Damping Options
 P = Damping in both directions
 N = Damping on in stroke only
 M = Damping on out stroke only
 X = Special model suffix

The end fittings are interchangeable and must be positively secured by the customer to prevent unscrewing (i.e. Loctite). For mounting accessories see page 200.

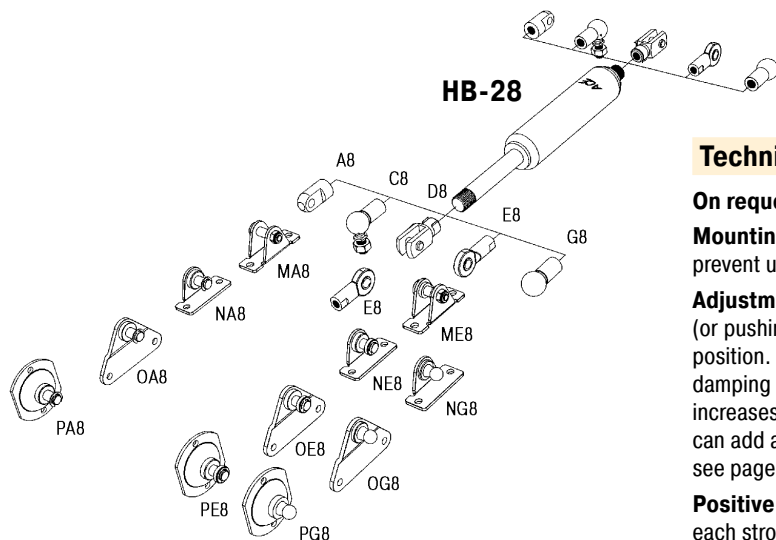

For mounting accessories see page 200.

Technical Data

On request: Special lengths, alternative seals and end fittings.

Mounting: In any position. End fittings must be positively secured to prevent unscrewing.

Adjustment: Adjustment of the damping rate is achieved by pulling (or pushing) the piston rod to its fully extended (or compressed) position. Whilst still pulling the piston rod turn it clockwise to increase damping and anti-clockwise to decrease damping. If the resistance increases noticeably, stop adjusting to avoid damage. The adjustment can add a max. of 6 mm to the L dim. shown (adjustment instruction see page 159).

Positive stop: Provide mechanical stops 1 to 1.5 mm before end of each stroke direction.

Free travel: Construction of standard damper results in a free travel of approx. 20% of stroke.

Material: Body: Black coated steel. Piston rod: With wear-resistant coating. End fittings: Zinc plated steel.

End Fitting

Standard Dimensions

End Fitting



B14

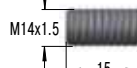

Stud Thread B14

C14

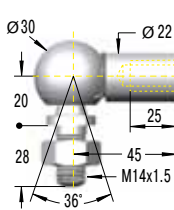

Angle Ball Joint C14

max. force 3200 N

D14

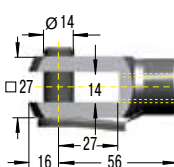

Clevis Fork D14

max. force 10000 N

E14

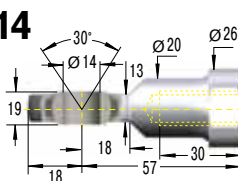

Swivel Eye E14

max. force 10000 N

Dimensions

Type	Stroke mm	L extended	1 Max. Compression Force N
HB-40-100	100	275	10 000
HB-40-150	150	375	10 000
HB-40-200	200	475	10 000
HB-40-300	300	675	10 000
HB-40-400	400	875	8 000
HB-40-500	500	1 075	6 000
HB-40-600	600	1 275	4 000
HB-40-700	700	1 475	3 000
HB-40-800	800	1 675	3 000

1 Max. extension force for all stroke lengths 10 000 N.

Ordering Example

Type (Hydraulic Damper) _____
 Body Ø (40 mm) _____
 Stroke (300 mm) _____
 Piston Rod End Fitting E14 _____
 Body End Fitting E14 _____
 Damping Direction (N = in stroke only) _____

HB-40-300-EE-N

Damping Options

- P = Damping in both directions
- N = Damping on in stroke only
- M = Damping on out stroke only
- X = Special model suffix

Rod Shroud W14-40

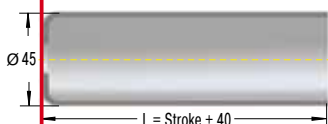

The end fittings are interchangeable and must be positively secured by the customer to prevent unscrewing (i.e. Loctite). For mounting accessories see page 201.

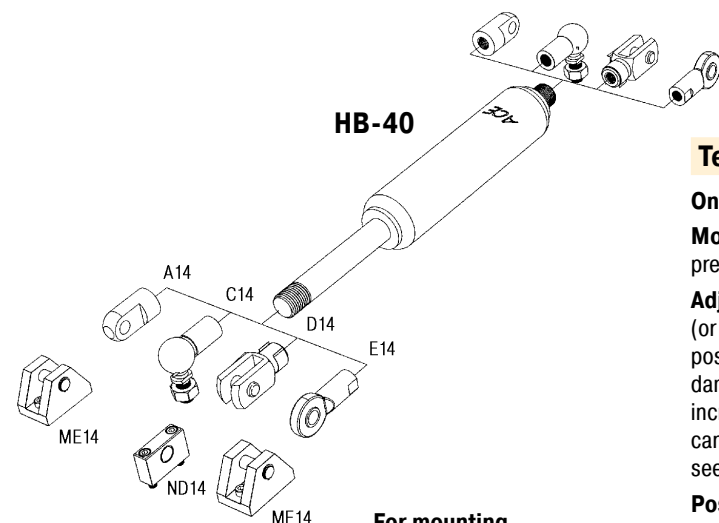

For mounting accessories see page 201.

Technical Data

On request: Special lengths, alternative seals and end fittings.

Mounting: In any position. End fittings must be positively secured to prevent unscrewing.

Adjustment: Adjustment of the damping rate is achieved by pulling (or pushing) the piston rod to its fully extended (or compressed) position. Whilst still pulling the piston rod turn it clockwise to increase damping and anti-clockwise to decrease damping. If the resistance increases noticeably, stop adjusting to avoid damage. The adjustment can add a max. of 6 mm to the L dim. shown (adjustment instruction see page 159).

Positive stop: Provide mechanical stops 1 to 1.5 mm before end of each stroke direction.

Free travel: Construction of standard damper results in a free travel of approx. 20% of stroke.

Material: Body: Black coated steel. Piston rod: With wear-resistant coating. End fittings: Zinc plated steel.

End Fitting

Standard Dimensions

End Fitting

B24



Stud Thread **B24**

D24

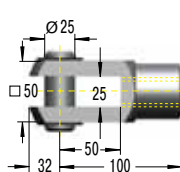

Clevis Fork D24
max. force 50 000 N

E24

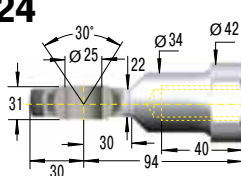

Swivel Eye E24
max. force 50 000 N

Dimensions

Type	Stroke mm	L extended	1 Max. Compression Force N
HB-70-100	100	320	50 000
HB-70-200	200	520	50 000
HB-70-300	300	720	50 000
HB-70-400	400	920	30 300
HB-70-500	500	1 120	21 600
HB-70-600	600	1 320	16 200
HB-70-700	700	1 520	12 600
HB-70-800	800	1 720	10 100

¹ Max. extension force for all stroke lengths 50 000 N.

Ordering Example

Type (Hydraulic Damper) _____
 Body Ø (70 mm) _____
 Stroke (300 mm) _____
 Piston Rod End Fitting E24 _____
 Body End Fitting E24 _____
 Damping Direction (N = in stroke only) _____

HB-70-300-EE-N

Damping Options

- P = Damping in both directions
- N = Damping on in stroke only
- M = Damping on out stroke only
- X = Special model suffix

The end fittings are interchangeable and must be positively secured by the customer to prevent unscrewing (i.e. Loctite). For mounting accessories see page 201.

**Rod Shroud
W24-70**

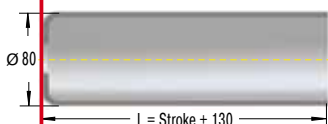

Technical Data

On request: Special lengths, alternative seals and end fittings.

Mounting: In any position. End fittings must be positively secured to prevent unscrewing.

Adjustment: Adjustment of the damping rate is achieved by pulling (or pushing) the piston rod to its fully extended (or compressed) position. Whilst still pulling the piston rod turn it clockwise to increase damping and anti-clockwise to decrease damping. If the resistance increases noticeably, stop adjusting to avoid damage. The adjustment can add a max. of 8 mm to the L dim. shown (adjustment instruction see page 159).

Positive stop: Provide mechanical stops 5 to 6 mm before end of each stroke direction.

Free travel: Construction of standard damper results in a free travel of approx. 20% of stroke.

Material: Body: Black coated steel or zinc plated steel. Piston rod: Hard chrome plated. End fittings: Zinc plated steel.

Separator piston: Available as a special option to remove free travel. Also provides extension force of min. 250 N. Increases dimension L + 150 mm. Part number: Add suffix -T.

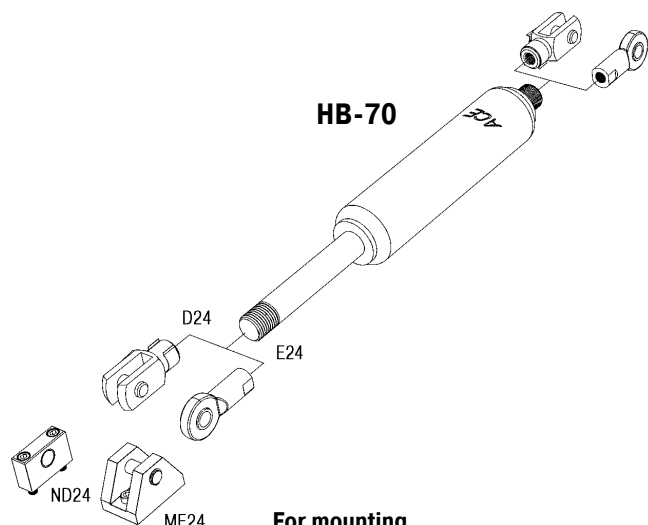

For mounting accessories see page 201.

Adjustment Instructions for HB-15 to HB-70 and HBS-28 to HBS-70



Adjustment only possible when piston rod is **fully** extended or **fully** compressed.

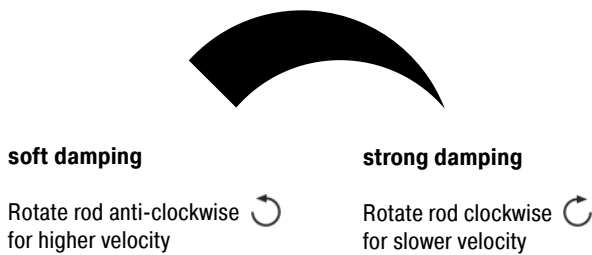

1. Hold outer body.
2. a) When piston rod is fully extended:
Adjust damping by turning the piston rod as shown in the picture. Whilst rotating, pull the piston rod gently, to ensure the adjuster locates in the end cap.
- b) When the piston rod is fully compressed:
Adjust the damping by turning the piston rod as shown in the picture. Whilst rotating, push the piston rod gently, to ensure the adjuster locates in the end cap.
3. When resistance is felt when rotating the piston rod, stop turning. You will be at the end of the adjustment.
NOTE: Do not rotate piston rod too quickly as damage could occur.
4. Check the damping, if required repeat step 1 to 3.
5. On all versions with a separator piston (type "T") adjustment is only possible when the piston rod is extended (adjustment 2a).

Adjustment Instructions for HB-12



Standard Dimensions TD-28

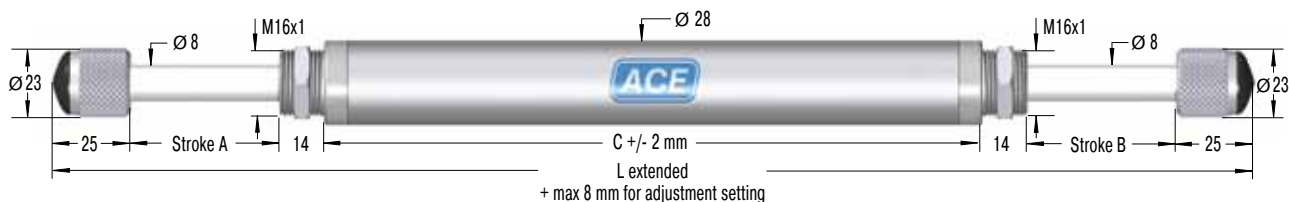

Ordering Example

Type (Door Damper) _____
 Body Ø (28 mm) _____
 Stroke A (50 mm) _____
 Stroke B (50 mm) _____

TD-28-50-50

Return Type

F = automatic return with return spring
 D = without return spring. When one piston is pushed in, the piston rod at the other end is pushed out (thus the damper must be impacted from alternate ends to sequence correctly).

Dimensions and Capacity Chart

Type	Stroke A mm	Stroke B mm	C	L max	Max. Impact Mass kg	Max. Damping Force Q N	Max. Energy Capacity		Max. Return Force N	Return Type
							W_3 Nm/Cycle			
TD-28-50-50	50	50	220	402	150	1 550	75		30	F
TD-28-70-70	70	70	260	482	200	1 500	70		30	F
TD-28-100-100	100	100	220	502	250	1 500	80		40	F
TD-28-120-120	120	120	208	410	250	3 800	165		0	D

Standard Dimensions TDE-28

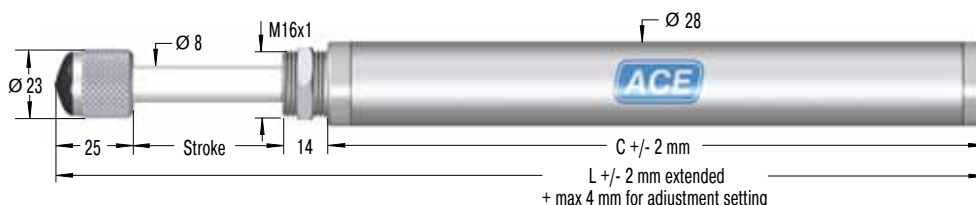

Ordering Example

Type (Door Damper) _____
 Body Ø (28 mm) _____
 Stroke (50 mm) _____

TDE-28-50

Technical Data

On request: With different deceleration characteristics, special stroke lengths, special seals etc.

Impact velocity range: 0.1 to 2 m/s

Adjustment: Pull the piston rod fully out and turn the knurled rod end button. The internal toothed adjustment allows the damping to be separately adjusted for each side. As a result of the adjustment mechanism the overall length L can be increased by up to 4 mm.

Material: Piston rod: Hard chrome plated steel. Cylinder body: Zinc plated steel.

Operating temperature range: -20 °C to 80 °C

Function: ACE door dampers are single ended or double ended adjustable hydraulic shock absorbers used for the cushioning of elevator doors, automatic and sliding doors and similar applications.

Strokes per minute: max. 10

Dimensions and Capacity Chart

Type	Stroke mm	C	L max	Max. Impact Mass kg	Max. Damping Force Q N	Max. Energy Capacity		Max. Return Force N
						W_3 Nm/Cycle		
TDE-28-50	50	130	221	4 000	2 400	80		30
TDE-28-70	70	158	269	5 600	2 400	112		30
TDE-28-100	100	193	333	8 000	2 400	160		30
TDE-28-120	120	214	373	7 000	2 400	190		40

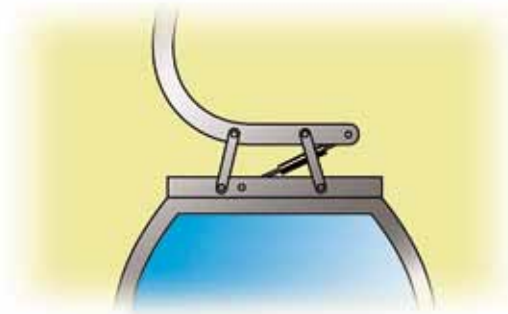

Swinging movements cushioned by hydraulic dampers

Passengers always feel the swinging movement involved when cable cars arrive at the ski station.

Maintenance-free **hydraulic dampers** type **HB-40-300-EE-X-P** cushion these movements perfectly. Designers of the cable cars, connected by means of an articulated joint via a four-point frame and connection guide to the suspension rod, profit from the ability of the adjustable dampers to absorb compressive forces of up to 10 000 N on either side.



Hydraulic dampers for added convenience when operating cable cars

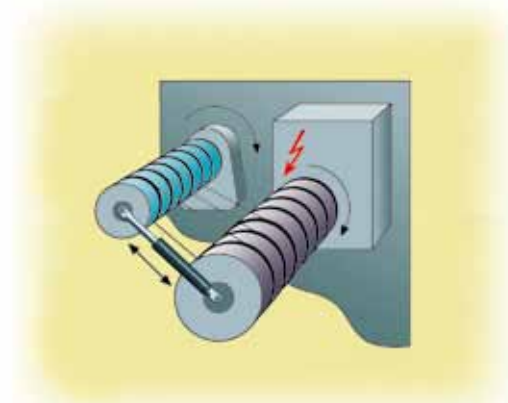

Precise unreeling

Hydraulic dampers bring the sled movement of this textile machine to a gentle stop.

At the turning point of 130 kg reeling spools, a sled should move up and down smoothly without causing a collision at the end of stroke position. The solution was provided by the hydraulic damper **DVC-32-100EU**. A self-contained sealed unit, ready to install and maintenance-free these units are ideal for precise control of speeds in both directions of travel. The travel speed is maintained throughout the entire stroke and can be independently adjusted in each direction of travel. Thanks to their compact design and wide choice of mounting accessories, these dampers could be easily integrated into this machine.



Textile machine unreels threads even better